

**DESIGN STANDARDS
&
STANDARD PLANS
2015**



**DEPARTMENT OF PUBLIC WORKS
ONE MAIN STREET
RIO VISTA, CALIFORNIA**

RESOLUTION NO. 2015-082

**A RESOLUTION OF THE CITY COUNCIL OF THE CITY OF RIO VISTA
ADOPTING UPDATED DESIGN STANDARDS AND STANDARD PLANS 2015, FOR
THE DESIGN, CONSTRUCTION AND REPAIRS OF PUBLIC UTILITIES AND
INFRASTRUCTURE WITHIN THE CITY**

WHEREAS, the Original Standards were adopted in 1983 by Council Resolution 83-45, and;

WHEREAS, Amendments to the Standards were made in 1985, 1990 and 1995 by City Council Resolutions, and;

WHEREAS, The Standards have not been revised in 20 years and are in need of updating, and;

WHEREAS, The project budget was \$70,000.00 and the project costs totaled \$67,000.00 and;

WHEREAS, the funding for the project was supplied by 8 different sources as identified in the Council Agenda Report, and;

NOW THEREFORE, BE IT RESOLVED BY THE CITY COUNCIL OF THE CITY OF RIO VISTA that the City Council does hereby adopt the updated Design Standards and Standard Plans 2015, for the design, construction and repairs of public utilities and infrastructure within the City.

PASSED, ADOPTED AND APPROVED the 1st day of December, 2015 by the following roll call vote:

AYES: Council Members Boulware, Kott, McCracken, Vice Mayor Hampton,
& Mayor Richardson
NOES: None
ABSENT: None
ABSTAIN: None

ATTEST:



Marni Rittburg, Deputy City Clerk



DESIGN STANDARDS

Table of Contents

Division 0 – Rio Vista Standards Plan Outline

Division I – Design Standards

Section 1: Purpose and Definitions

Section 2: General requirements

Section 3: Street Design

Section 4: Storm Drainage

Section 5: Sanitary Sewers

Section 6: Water System

Section 7: Street Lighting

Division II – Private Development Standards

Section 1: General Information

Section 2: Design Requirements

Division III – Standard Plans

100 Trenches

101 Trench Backfill

200 Streets

201 Typical Street Section Requirements

202 Street Section

203 Street Section

204 Cul-De-Sac Turn Around

205 Cul-De-Sac Turn Around

206 Expanded Corner

207 Curb and Gutter

208 Curb and Gutter Replacement in Existing Streets

209 Monolithic Sidewalk

210 Separated Sidewalk

211 Rolled Curb, Gutter & Sidewalk

212 Sidewalk Repair

213 Residential Driveway

214 Vertical – Type Curb, Gutter, Sidewalk and Residential Driveway

215 Commercial and Industrial Driveway with Separated Sidewalk

216 Special Commercial Driveway

217 Valley Gutter

218 Handicap Ramp

219 Handicap Ramp Notes

220 Handicap Ramp Notes

221 Curb Ramp Groovings and Detectable Warning Surface

222 Standard Utility in Street Location

223 Typical Utility Layout

224 Asphalt Concrete Dike

225 Parallel Parking Spaces

226 Parking Standards

227 Parking Standard Notes

228 Handicap Parking Layout

229 Standard Stop Sign

230 Standard Street Sign

231 Standard Monument

232 Tree Planting

233 Tree Planting Notes

234 Standard Barricade

300 Storm Drain

- 301 Catch Basin
- 302 Storm Drain Manhole
- 303 Flat Slab Manhole Top
- 304 Saddle Manhole
- 305 24" Monitoring Structure
- 306 Yard Drain through Curb
- 307 Standard Community Detention Basin
- 308 Erosion Control Pipe Discharge
- 309 Rainfall – Intensity, Duration, Frequency

400 Sewer

- 401 Residential Sewer Service With Clean Out
- 402 Sewer Flushing Inlet
- 403 Sewer Manhole
- 404 Sewer Manhole with Inside Drop Connection
- 405 Sewer Manhole Abandonment
- 406 Standard Manhole Channelization

500 Water

- 501 Water Service 1" to 2"
- 502 Double Check Detector Assembly
- 503 Reduced Pressure Backflow Preventer
- 504 Air Valve Assembly
- 505 Typical Valve and Water Main Installation 6" thru 12"
- 506 2" Blowoff
- 507 Fire Hydrant Lateral and Valve Assembly
- 508 Hydrant Marker (Blue Dot) Locations
- 509 Thrust Block Bearing Area Detail

600 Street Lights

- 601 Street Light Service Point
- 602 Standard Street Light
- 603 Intersection Lighting
- 604 Street Light Conduits & Conductors Encasement
- 605 Roadway Illumination

SECTION 1 PURPOSE AND DEFINITIONS

1.01 PURPOSE

The purpose of these Design Standards is to provide certain minimum standards for the design, construction, repair and alteration of streets, roadways, alleys, drainage, sewerage, parks, landscaping, irrigation, water supply facilities and all appurtenances thereto, within the City of Rio Vista, where any portion of such improvement is to be dedicated to the City of Rio Vista and accepted for operation and/or maintenance. Any items which are not included in these Standards shall be designed in accordance with the State Highway Design Manual, State Traffic Manual, Subdivision Ordinance or Zoning Ordinance as hereinafter defined, the General Plan, Master Plans, and any applicable Specific Plan of the City of Rio Vista, generally accepted engineering practice, or as directed by the City Engineer.

1.02 DEFINITIONS

In these Design Standards, the Standard Construction Specifications and the Standard Details, the intent and meaning of the terms that are used shall be as defined in the General Conditions of the Standard Specifications, except as modified or added hereafter.

- A. CITY - Shall mean the City of Rio Vista, a municipal corporation.
- B. CITY ENGINEER - Shall mean the City Engineer of the City of Rio Vista, California, or his/her representative.
- C. CONSULTING ENGINEER - Any person or persons, firm, partnership, or corporation legally authorized to practice Civil Engineering in the State of California who prepares or submits improvement plans and specifications to the Community Development Department of the City of Rio Vista for approval.
- D. DESIGN - Shall mean street alignment, grade, geometric section, and structural section; sanitary sewer alignment, grade, and size; water system alignment, size, valving, and fire hydrant location; storm drain alignment, grade, and size; and miscellaneous improvements as required by the City Engineer.
- E. DEVELOPER - Shall mean any person, firm, corporation, partnership or association engaged in the development of property in part or in whole by the placing of any improvements thereon, whether the property was previously developed in whole, in part, or at all.
- F. EASEMENT - Shall mean an easement dedicated to the City or Public Utility, which shall be continuing and irrevocable unless formally abandoned.

- G. ENGINEERING DIVISION - Shall mean the Engineering Division of the Public Works Department of the City of Rio Vista.
- H. GRADING ORDINANCE – Shall mean the “Grading Ordinance” of the City Code as adopted by the City Council of the City of Rio Vista.
- I. IMPROVEMENTS - Refers to street work, sidewalk, curb, gutter driveways, water mains, sanitary sewer, storm drainage, street lighting, traffic signals, public utilities, landscaping, irrigation, parks, fences and other facilities to be constructed or installed by the developer within an existing or future public right of way or easement and other improvements which the City Engineers office is responsible for performing plan checking and inspection.
- J. LATEST EDITION - Shall mean the most recent edition of the subject document, which has been adopted by the City of Rio Vista.
- K. MANUAL OF TRAFFIC CONTROLS - Shall mean the “Manual of Traffic Controls for Construction and Maintenance Work Zones”, of the State of California, Department of Transportation, latest edition.
- L. PUBLIC IMPROVEMENT PLANS - Plans prepared for construction of public improvements required of subdivisions and all other work performed within the City right-of-way or easements.
- M. RECORD DRAWING – Plan sheet(s) depicting the “as-built” condition of all public improvements constructed including, but not limited to, water, sewer and storm drain improvements including plans & profiles; and curb, gutter sidewalk, roadway and landscaping improvements.
- N. SITE DEVELOPMENT PLANS - Plans for construction of improvements for commercial, industrial, and multi-family development located outside of City right-of-way or easements.
- O. SOILS REPORT - Shall mean a report as prepared by any person or persons, firm, partnership, or corporation legally licensed to prepare “Soils Reports” in the State of California.
- P. SOILS (GEOTECHNICAL) ENGINEER – Shall mean any person or persons, firm, partnership or corporation legally licensed and qualified to perform Geotechnical Engineering in the State of California.
- Q. STANDARD CONSTRUCTION SPECIFICATIONS - Shall mean the “Standard Construction Specifications” of the City of Rio Vista, latest edition.
- R. STANDARD DETAILS - Shall mean the “Standard Details” of the City of Rio Vista.

- S. STATE HIGHWAY DESIGN MANUAL - Shall mean the “Highway Design Manual” of the State of California Department of Transportation, latest edition.
- T. STATE TRAFFIC MANUAL - Shall mean the “Traffic Manual” of the State of California, Department of Transportation, latest edition.
- U. STATE STANDARD SPECIFICATIONS - Shall mean the “Standard Specifications” of the State of California, Department of Transportation, latest edition, unless otherwise stated.
- V. STATE STANDARD DETAILS- Shall mean the “Standard Plans” of the State of California, Department of Transportation, latest edition, unless otherwise stated.
- W. SUBDIVISION ORDINANCE - Shall mean the “Subdivision Ordinance” of the City Code as adopted by the City Council of the City of Rio Vista.
- X. ZONING ORDINANCE - Shall mean the “Zoning Ordinance” of the City Code as adopted by the City Council of the City of Rio Vista.

SECTION 2 GENERAL REQUIREMENTS

2.01 GENERAL

Complete plans and specifications for all proposed improvements including any necessary dedications for rights-of-way and easements shall be submitted to the Engineering Division of the Public Works Department for approval and must receive the required approval prior to the beginning of construction of any such improvements. This shall apply where it is the intent that any portion of such improvement will be dedicated to and accepted by the City of Rio Vista. Such plans shall be prepared by or under the supervision of a Registered Civil Engineer in accordance with the provisions of "Professional Engineer's Act", Division 3, Chapter 7 of the Business and Professions Code, relating to the practice of Civil Engineering.

2.02 PREPARATION OF IMPROVEMENT PLANS

A. Public Improvement Plans

Public improvement plans shall be prepared for public improvements required of subdivisions and all other work performed within City rights-of-way or easements that is in excess of minor work. For the purposes of this section, minor work shall consist generally of the construction, or the removal and replacement of curbs, gutters, sidewalks or driveways; minor street widening; connections to existing water, sewer or storm drainage facilities adjacent to site development; and utility-related work.

1. Form of Public improvement plans.

The following requirements apply to the form of public improvement plans. A separate title sheet shall not be required when the total number of sheets of improvement plans is fewer than three. If a title sheet is not required, the following requirements shall still apply to the improvement plans except those identified by an asterisk (*).

a. Dimensions

Improvement plans shall be clearly and legibly drawn in ink on engineering mylar (polyester film, 3 mil), 24 inches by 36 inches in dimension, with a 1-1/2 inch wide clear margin on the left edge and 1-inch wide margins on all other edges, or as otherwise approved by the City Engineer.

b. Scale

Horizontal scale shall be 1 inch = 40 feet; vertical scale shall be 1 inch = 4 feet, or as otherwise approved by the City Engineer.

2. Title Sheet

- a. Name of subdivision or project.
- b. Vicinity map
- c. Index of sheets.
- d. City Engineer's signature block.
- e. Complete legend showing all abbreviations and symbols.
- f. Title Block – located along lower edge or right edge of paper.
- g. General and special notes relating to construction methods. The following note shall be included in the General Notes: "All work shall conform to the City of Rio Vista Standard Specifications".
- h. Names, addresses and telephone numbers of the project soils engineer(s), developer's representative, design engineer(s), Community Development Department Representative and all affected public utility companies and reclamation district representative's.
- i. Design Engineer's stamp and signature.
- j. "USA Call Before You Dig" Note

3. Street Plan and Profile Sheets

- a. Plan view of each street to be improved shall be shown on separate sheets and shall include existing improvements and contours/elevations within 100 feet of the project boundary, proposed improvements and future improvements if known. Improvements to be shown shall include sidewalk, curbs, gutters, driveways, sewer mains, water mains, water service and sewer lateral locations, storm drains, manholes, joint utility trench locations, public utility vault locations, lot utility service locations, valves, fire hydrants, fencing, barricades, monuments, survey stationing, face of curb data for all curves and other data as required by the City Engineer. Distinct elevations shall be shown along the face of curb at all beginning and end of curves, all curb returns, and all grade breaks. The survey stationing shall normally read from left to right with the north arrow pointing either to the top or right edge of the sheet. All stationing shall be a continuation of existing improvements where possible.
- b. Profile view of each street shall be shown immediately below its plan view. The profile shall include existing and proposed street centerlines, sewer mains, storm drains, water mains, public utility mains, all utility crossings, and gutter flow lines. Distinct elevations shall be shown on the street centerline and top of curb at 50-foot stations and grade break points, manhole and catch basin inverts, and water main crossings with other utilities. Rates of grades shall be shown on all profile lines. Elevations of the hydraulic grade line for the 10-year and 100-year frequency storms shall be shown at all locations of storm drain manholes, catch basins and drain inlets.

4. Signing and Striping Plan

All existing and proposed traffic signing and striping shall be shown on a plan view and on separate sheets from all other improvements. The scale shall be 1 inch equals 40 feet, or as otherwise approved by the City Engineer. Signing and striping to be shown shall include all existing and proposed traffic striping, pavement markings, pavement markers, regulatory signs and warning signs. All existing signing and striping within at least 200 feet of the project limits shall also be shown.

5. Street lighting Plan

The street lighting plan shall include the location of proposed electroliers, service point(s), pull boxes, conduit run showing wire size and length, wiring diagrams, and the mounting height and arm length of the proposed electrolier/pole assembly. The street lighting plan shall be drawn on a separate sheet with a minimum scale of 1" inch equals 40' feet, or as otherwise approved by the City Engineer.

B. Grading Plan

1. Requirements

When required by the Grading Ordinance a grading plan shall be prepared. The plan shall be drawn to scale and shall be of sufficient clarity to indicate the nature and extent of the work proposed. The plan shall also provide sufficient information to determine that the proposed work conforms to the provisions of the Grading Ordinance, as adopted by the City Council, and all relevant laws, other ordinances and regulations. The plans shall include, as a minimum, the following information:

- a. The boundaries of the site and accurate contours of existing grades and details of terrain and drainage area.
- b. Dimensions, elevations and finish contours to be achieved by the grading;
- c. Proposed elevations along the back of sidewalk at all grade breaks, and at the projected intersection of each side lot line or every 100 feet, whichever is less;
- d. Locations, species and sizes of heritage and significant trees, and temporary and permanent facilities to protect and ensure the preservation of said trees;
- e. All existing and proposed surface and subsurface drainage facilities including drain inlets, underground pipes, and surface swales and channels, and any other drainage improvements proposed to be constructed with, or as a part of the proposed work, together with proposed grades and slopes;
- f. Locations of existing and proposed buildings or structures on the site, including proposed pad and finished floor elevations;

g. Existing grades and elevations of adjoining properties adequate to define existing drainage patterns, the location of any buildings or structures on land of adjacent owners which are within 15 feet of the property or which may be impacted by the proposed grading operations.

h. Typical Lot Detail

2. Separate Approval

The developer, design consultant, or contractor has the option to request approval of a grading plan for issuance of a grading permit prior to issuance of a building permit. The grading plan shall at a minimum contain the information listed above and will be reviewed and approved by the City Engineer in accordance with the City's Grading Ordinance. Upon approval, the grading plans will be stamped "Approved For Grading Only" by the City Engineer and the applicant will be issued a grading permit to proceed with grading of the proposed site. However, no construction in excess of grading will be permitted until approval of the public improvement plans have been obtained.

3. Grading Plans

Performance securities submitted for issuance of the grading permits will not be released until the grades shown on the approved grading plans, whether they are subgrade elevations or finished grade elevations have been certified in writing by a registered civil engineer or licensed land surveyor.

4. Other Plans

Other plans that may be incorporated in the public improvement plans include, but are not necessarily limited to, landscaping and irrigation; retaining, decorative or sound walls; joint utility trench; erosion control; specific road closure and detour; and traffic signal plans. The City Engineer on a case-by-case basis will establish specific requirements for these plans.

C. Site Development Plans

Site development plans shall be prepared for on-site commercial, industrial and multifamily residential developments.

1. Form of Site Development Plans

The following requirements apply to the form of site development plans.

a. Plans shall be clearly and legibly drawn at horizontal scale of 1" inch=40 feet or as otherwise approved by the City Engineer.

- b. Existing and proposed building pad and finished floor elevations. In addition, the improvement plans shall include the existing or proposed top back of curb or sidewalk and crown of street elevations along the entire frontage of the proposed site at 50-foot intervals and at the property boundaries of the site.
- c. All existing and proposed underground utilities including, but not necessarily limited to, water, sanitary sewer, and storm drainage including their connections to the public systems. This shall include the existing and proposed invert and rim elevations at all manholes, drain inlets, and catch basins.
- d. All existing and proposed improvements within the street right-of-way including but not limited to sidewalk, curb and gutter, street lights, fire hydrants, drive ways, water laterals and meters, water backflow preventers, sanitary sewer services and clean-outs/sampling manholes, and any other public appurtenances.
- e. All on-site surface improvements including curbing, pavement, gutters, fencing, barrier walls and walkways, with appropriate typical cross sections.
- f. Individual lot and adjacent land drainage. Adjacent lot grades shall be shown for a minimum of twenty-five feet from the project boundary with adequate detail to define existing drainage patterns.
- g. Locations and widths of all existing and proposed driveways.
- h. Existing and proposed contours and grades, trees including species and size (existing only), wells, ditches, and other landmarks important to the construction of the proposed improvements or as required by the City Engineer.
- i. Site plans for tenant improvements including projects involving minor modifications and/or additions to existing buildings, structures, surface improvements, and underground utilities shall also include:
 - 1. Current assessors parcel number of the subject parcel(s).
 - 2. Owner information and street address of the proposed tenant improvement.
- j. Design Engineer's stamp and signature.
- k. Required General Notes as listed below:
 - 1. All public improvement construction shall conform to the City of Rio Vista Standard Specifications and shall be subject to a City Encroachment Permit.
 - 2. All underground water, sewer, and storm drain systems including their appurtenances within the building site property up to within five (5) feet of the building shall conform to the City of Rio Vista Standard Specifications and shall be inspected by the City Engineer with the exception of

underground fire lines located on the private side of the public fire backflow preventer.

3. Work shall include replacement of all broken public sidewalk, curb and gutter. This work should take place when there is no further need for encroachment of heavy equipment over walks and prior to City approval of the building for occupancy. The City Engineers Inspector will mark all broken curb, gutter and sidewalk for replacement upon request.
4. The City Engineers Inspector will inspect the main water service tap and lateral, the domestic meter assembly and the domestic and fire backflow assemblies.
5. Pavement design by a Soils Engineer shall be required. The minimum surface slope shall be 1%. Written certification of pavement grade by a licensed Civil Engineer or Land Surveyor, and certification of the structural section and compaction by a Geotechnical Engineer shall be required prior to the issuance of building permit final or a Certificate of Occupancy.
6. The Geotechnical Engineer shall be on-site to monitor all grading operations. The Geotechnical Engineer shall provide written certification that the site grading was performed in accordance with the Soils Report by (No.) prior to issuance of a Certificate of Occupancy.
7. All utility work including electrical, gas, telephone, and cable TV shall be subject to an Encroachment Permit. Normally, the utility companies obtain separate permits for their work. It is the responsibility of the applicant to ensure that this has been done prior to beginning work.
8. All underground facilities shall be located by the appropriate agencies prior to any excavation. This shall be initiated through Underground Service Alert (U.S.A.) by calling (800) 227-2600.
9. The Contractor is responsible for temporary erosion control, at all times. Temporary erosion control shall consist of, but not be limited to, constructing such facilities and taking such measures as are necessary to prevent, control and abate water, mud and erosion damage to public and private property as a result of the project. By October 15th of each year, or earlier if conditions warrant, such temporary erosion control features as are necessary to prevent damage during the forthcoming winter season shall be constructed and functioning. Mud and silt shall be settled out of the storm runoff before said runoff leaves the construction site or enters the City storm drain systems, or a natural channel. Any project shall comply with all requirements and permits from the Regional Water Quality Control Board.

10. Any water entering the sanitary sewer system to be constructed under the approved plans shall not be discharged to the existing city sewer system. Plugs shall be installed in existing manholes as necessary to permit pumping the new system clear of water and debris prior to acceptance by the City. Care shall be exercised in locating plugs to avoid interrupting service to existing connections. Mechanical plugs or mortar and brick must be used. Inflatable devices are not allowed.

2.03 SUBMISSION OF IMPROVEMENT PLANS

A. Public Improvements Plans:

A minimum of three sets of prints of public improvement plans shall be submitted to the City Engineer for checking to insure compliance with these Standards, City Ordinances, and generally accepted engineering practice. Submitted plans shall include, as a minimum, an itemized engineer's cost estimate, drainage calculations, sewer calculations, and a soils report including proposed street structural section design. Additional materials that may be required for submission include technical specifications, test data, materials lists, legal descriptions and grant deeds for right-of-way and easement dedications, and other materials as required by the City Engineer. The City Engineer may also require the submission of a network analysis for the water distribution system.

B. Site Development Plans

Three sets of prints of improvement plans for site development of commercial, industrial and multi-family uses shall be submitted to the Building Department for the City Engineers approval at the time the application is made for a building permit. The following requirements also apply to building permits for single family and duplex dwellings, except items 1, 2, and 3 below may be omitted at the discretion of the City Engineer. Site development Plans shall be designed and constructed in conformance with Division II of these Standard Specifications. In addition to the improvement plans, the following shall also be submitted directly to the Engineering Division.

1. An itemized engineer's cost estimate of improvements to be constructed within public rights-of-way or easements, which are to be accepted for operation and/or maintenance by the City. The unit costs of improvements in the engineer's estimate shall be subject to approval by the City.
2. An itemized engineer's cost estimate of all on-site grading, paving, water, sewer, and storm drain improvements which shall be designed and constructed in accordance with Division II of these Standard Specifications. This unit costs of this is also subject to approval by the City.

3. Payment of the Plan checking and inspection fee, in accordance with the Engineering Division fee schedule adopted by the City Council, based on the estimated cost of improvements from items 1 and 2 above.
4. One copy each of the plumbing plan and floor plan for the proposed building which includes an itemized listing of proposed plumbing fixtures to be removed and/or installed, including type and quantity.
5. Two copies of the soils report prepared by a registered geotechnical engineer for the proposed project. The report shall include a recommendation for on-site pavement design, and street pavement sections. The pavement sections for public streets shall be based upon traffic indices specified in Division I, Section 3 of these Standard Specifications. On-site pavement design shall be based upon traffic indices specified in Division II, Section 2 of these Standard Specifications.
6. One copy of each on-site storm drainage calculations for a 10-year and a 100-year frequency storm. Calculations shall be completed in accordance with Division I, Section 4 of these Standard Specifications.
7. One copy of sewer calculations for the proposed on-site sanitary sewer system/prepared in accordance with Division I, Section 5 of these Standard Specifications.
8. A completed application for an industrial discharge permit (if required). Provided with this application shall be the estimated quantity and strength (in BOD, COD, and Suspended Solids) of average sanitary sewer flows from the project.

C. Grading Plans

Three (3) sets of prints of grading plans shall be provided to the City Engineer for approval. The City Engineer will review and approve the grading plans in accordance with the City's Grading Ordinance for all on-site development projects. In addition, the following shall also be submitted:

1. One copy of the soils report prepared by a registered geotechnical engineer for the proposed project.
2. One copy each of the on-site drainage calculations for both a 10-year frequency storm and a 100-year frequency storm in accordance with Division I, Section 4 of the Standard Specifications.
3. The application, plan checking, and inspection fee shall be paid at the time the application is submitted.

2.04 SUBMISSION OF SOILS REPORTS

Soils Reports shall be submitted in 8-1/2 x 11 inch bound folders. The analysis shall, as a minimum, include a map of the subject area showing proposed and existing streets, contours and location and type of soils samples obtained. The results of all field data and laboratory tests shall also be included. Design for proposed street sections shall be part of the report. Street structural section design shall include recommendations for: natural subgrade, geotextile fabric, subbase, base and pavement compaction and thickness to achieve design strength.

2.05 PLAN CHECKING AND INSPECTION FEES

Payment for plan checking and inspection fees shall be made at the initial plan submittal for public improvement and site development plans. This payment shall be 100 percent of the estimated total amount of the plan check and inspection fee, in accordance with the fee schedule adopted by the City Council, and is nonrefundable.

2.06 SUBMISSION OF SUBDIVISION FINAL AND PARCEL MAPS

Three sets of prints of the parcel or final map shall be submitted for review to the City Engineer. Payment of the map checking fee deposit shall be made at the time of the initial submittal of the map. This payment shall conform to the fee schedule adopted by the City Council, and is non-refundable. All maps shall be submitted in conformance with the requirements specified within the City of Rio Vista Subdivision Ordinance.

2.07 CITY REVIEW AND APPROVAL OF IMPROVEMENT PLANS AND SUBDIVISION MAPS

A. City Review Time

Following submittal of a complete application, as determined by the City Engineer, a minimum of 20 working days shall be allowed for review of public improvement plans, site development plans and parcel or final maps. Additional time may be required depending on the extent and nature of the improvements, and the current workload of the City Engineers staff. At the time plans or maps are submitted, the submitting individual or firm may inquire if additional review time will be required.

B. Alterations to Plans or Maps

1. Should alterations or revisions be required to the plans or maps submitted, one copy will be returned to the consulting engineer with the required corrections indicated thereon. At such time as the consulting engineer has made the necessary revisions, the plans or map shall again be submitted (3 copies of plans, 3 copies of maps) for checking. The corrected or “marked” set of plans

or map shall be returned with the plan resubmittal. If the plans or map being resubmitted contain revisions or alterations other than those required by the City Engineer on previous corrections, the consulting engineer shall bring those revisions or alterations to the attention of the City Engineer.

2. If resubmitted plans do not contain corrections as shown on the previous “marked” set, or if the plans do not conform to these Standard specifications, or are not in keeping with the standards of the profession, the plans may be returned unmarked and unapproved. Public improvement plans shall not be considered approved until the City Engineer has signed in the approval block on the plans. Site development plans shall not be considered approved until the City Engineer has stamped them “Approved” and all Engineering fees have been paid.

C. Review By Other Agencies

1. If proposed storm drainage improvements are to be dedicated to a Reclamation District, or if any site improvements will affect Reclamation District facilities, the consulting engineer shall obtain approval of the Reclamation District prior to obtaining approval from the City Engineer. Reclamation District approval of improvement plans shall be indicated by the signature of an appropriate representative of the district on the title page.
2. Should the Improvement Plans be subject to review and approval by other regulatory agencies such as Caltrans, written approval from these agencies shall be provided to the City Engineer prior to plan approval.

D. Requirements Following Approval of Improvement Plans

1. Immediately after formal approval of the plans by the City Engineer, 3 copies shall be provided to the City Engineer for use by the City during construction. Additional copies of reduced improvement plans (11" x 17" or 18" x 26") may be required by the City Engineer at his/her discretion and shall be furnished by the developer or his representative to the City without cost.

E. Exceptions

1. Excepted from approval are any features of the plans that are contrary to, in conflict with, or do not conform to these Design Standards, the Standard Construction Specifications, the Standard Details, any California State Law, City of Rio Vista Ordinance or Resolution, or generally accepted engineering practice, in keeping with the standards of the profession, even though such errors, omissions or conflicts may have been overlooked by the City Engineer.

2.08 REVISIONS TO CITY APPROVED PUBLIC IMPROVEMENT PLANS

A. Developer Requested Changes

Should changes to public improvement plans be requested during construction, the Consulting Engineer shall first obtain the consent of the City Engineer.

1. Procedure

Procedure for obtaining approval by the City Engineer shall be as follows:

- a. The Engineer shall submit the proposed change shown in red.
- b. Following review and approval by the City Engineer of the proposed change, the Engineer shall submit the current approved plan in reproducible form showing the proposed change.
- c. The City Engineer will indicate approval for the change by initialing the plans in the revision block.
- d. Following return of the reproducible plan to the Engineer, the Engineer shall provide two sheets for each plan sheet affected by the change.
- e. The original proposal shall not be eradicated from the plans but shall be lined out.
- f. In the event that eradicating the original proposal is necessary to maintain clarity of the plans, approval must first be obtained from the City Engineer.
- g. The changes shall be clearly shown on the plans with the changes and approval by the City Engineer noted on a revision signature block.
- h. The changes shall be identified by the revision number in a triangle delineated on the plans adjacent to the change and on the revision signature block.

B. Changes Requested by City Engineer

The City Engineer may order changes in the plans in order to complete the necessary facilities or to conform to these Standard Specifications, or accepted engineering standards. The procedure for making changes in the plans ordered by the City Engineer shall conform to the above outlined process.

C. Minor Changes

Minor changes during construction, which do not affect the basic design of the improvements, may be made upon the authorization of the City Engineer without formally revising the plans. All minor changes shall be shown on record drawings submitted to the City upon project completion.

2.09 REVISIONS TO CITY APPROVED SITE DEVELOPMENT PLANS

A. Developer Requested Changes

Should changes to site development plans be requested during construction, the developer/contractor shall resubmit the affected plan sheets for approval by the City. In addition, the developer/contractor shall pay additional plan check and inspection fees, as determined by the City. The additional fee shall be paid in advance of providing additional plan checking and inspection services and charged per the current Fee Schedule.

1. Procedure

Revisions to the plans shall be made in the following manner:

- a. The original proposal shall not be eradicated from the plans but shall be lined out.
- b. The revision shall be clouded and shall be identified by a revision number in a triangle delineated on the plans adjacent to the change and on the revision signature block.
- c. The City Engineer will review each individual revision. Upon approval, of the proposed revision, the developer/contractor shall submit three (3) additional sets of revised plans, which will be stamped "Revision Approved by the City Engineer".

B. Minor Revisions

Upon approval by the City Engineer, minor revisions may be identified on a record drawing to be submitted in an acceptable format prior to permit being finalized.

2.10 INSPECTION OF IMPROVEMENTS

A. Commencement of Work

1. Public improvement plans signed by the City Engineer as approved constitute authority to work within City rights-of-way or easements. Minor work within City rights of way or easements, as defined in Section 2.02A of these Design Standards, may be performed following the

issuance of an encroachment permit by the City of Rio Vista.

2. The contractor shall provide written notice to the City Engineer of the intent to begin construction at least 48 hours prior to beginning construction. A pre-construction meeting shall be held with the City prior to beginning of construction. It shall be the responsibility of the contractor to arrange this meeting.

B. General Requirements

1. Any improvement proposed to be accepted by the City for ownership, maintenance and/or operation responsibility shall be subject to inspection and testing by the City Engineer's Inspector, representing the City of Rio Vista. The City Inspector will observe the progress and quality of the work and determine, in general, if the work is proceeding in accordance with the approved plans and these Standard Specifications. The City Inspector shall not be required to make comprehensive or continuous inspections to check the quality of the work, and shall not be responsible for construction means, methods, techniques, sequences, or procedures, or for safety precautions and programs in connection with the work. Visits and observations made by the City Inspector shall not relieve the Contractor of his obligation to conduct comprehensive inspections of the work and to furnish proper materials, labor, equipment and tools, and perform acceptable work, and to provide adequate safety precautions, in conformance with the approved plans and these Standard Specifications.
2. Whenever the Contractor varies the period during which work is carried on each day, he shall give due notice to the City Inspector so that proper City inspection may be provided. Any work done in the absence of the City Inspector shall be subject to rejection. Work performed without inspection may be required to be removed and replaced under proper inspection and the entire cost of removal and replacing, including the cost of City-furnished materials used in the work, shall be borne by the contractor, regardless of whether or not the work exposed is found to be defective.
3. Proper facilities for safe access for inspection to all parts of the work shall at all times be maintained by the Contractor/Developer for the necessary use of the City Inspector and other agents of the City, and agents of the Federal, State, or local governments at all reasonable hours for inspection by such agencies to ascertain compliance with laws and regulations.

C. Final Inspection

1. Within ten working days after receiving the request for final inspection from the Contractor/Developer, the City Inspector shall inspect the work.

The contractor shall correct defects or deficiencies in a diligent manner. At such time that the corrective work is complete, a second inspection shall be made by the City Inspector within ten working days to determine if all work has been completed and the previously mentioned defects have been corrected and completed in accordance with the approved plans and these Standard Specifications. Any further inspections by the City Inspector to correct any remaining defects or deficiencies will be subject to additional inspection fees in accordance with the adopted City Fee Schedule. Not until all such work has been completed will the improvements be considered for acceptance.

D. Overtime Inspection Services

1. Any inspection services performed beyond normal working hours, or on weekends or holidays, either at the request of the contractor/developer or at the discretion of the City Engineer, shall constitute overtime inspection work. Payment of fees in addition to the normal plan checking and inspection fees shall be made for these services. The amount of the additional fees shall conform to the fee schedule for plan checking and inspection fees as adopted by the City Council. If the overtime services are provided at the request of the contractor/developer, requests and payment shall be made at least 48 hours in advance. Granting of the request to provide overtime inspection shall be at the sole discretion of the City Engineer and shall be subject to the availability of inspection personnel. In addition, payment of fees for overtime inspection services directed by the City Engineer shall be paid prior to acceptance of the work by the City.

2.11 RECORD DRAWINGS PRIOR TO FORMAL ACCEPTANCE OF THE IMPROVEMENTS BY CITY COUNCIL

A. Requirements

It shall be the responsibility of the developer or his representative to provide record drawings of public improvement plans prepared in accordance with these Standard Specifications and Section 16.44.060 of the Subdivision Ordinance. One mylar (polyester film, 3 mil) sepia copy (with matte surface up) and one digital copy shall be filed with the City Engineer's Office for City records.

All digital files shall be submitted in a format that is readable and importable by industry standard GIS software, this includes GIS layers or Computer Aided Drafting (CAD). All digital files shall use State Plane Coordinate System, NAD 83 California State Plane, Zone II, US Foot.

2.12 ACCEPTANCE OF IMPROVEMENTS

A. General

No improvements will be accepted by the City until all improvements required of the contractor, subdivision, or development project have been completed and approved by the City Engineer.

B. Public Improvement Plans

Acceptance of improvements for which public improvement plans were required will be signified by notification in writing from the City Engineer.

C. Site Development Plans

1. Backflow Certification

All backflow devices inspected by the City Engineer shall be tested and approved by a certified tester prior to any permit final or Certificate of Occupancy.

2. Pavement/Compaction Certification

Pavement structural section and compaction of base and subbase materials shall be verified in writing by a registered geotechnical engineer prior to any permit final or Certificate of Occupancy.

3. Lines and Grades Certification

- a. Written certification that the lines and grades, including minimum pad elevations as appropriate, have been constructed to match those on the approved grading plan shall be received from a registered Civil Engineer or licensed Land Surveyor prior to any permit final or Certificate of Occupancy.
- b. Performance securities submitted for issuance of the grading permits will not be released until the grades shown on the approved grading plans, whether they are subgrade elevations or finished grade elevations have been certified.

4. Utility Work Certification

Prior to acceptance of subdivision improvements by the City, the City Engineer must receive letters from each utility company indicating that all required utility work had been completed to the satisfaction of the company.

5. General

a. Site Development

1. Acceptance of all improvements for which an encroachment, grading, or any other permit was issued by the City Engineer will be signified by the signature of the City Engineers Inspector on the permit. -
2. The Inspector's signature on any or all site development Engineering permits does not constitute automatic the City Engineers approval of a building permit final or a Certificate of Occupancy.

b. Subdivision Improvements

1. Subdivision improvements shall be formally accepted by City Council upon completion of all requirements.

SECTION 3 STREET DESIGN

3.01 GENERAL

1. All streets shall be designed in accordance with accepted engineering principles and shall conform to these Design Specifications. Any deviation shall require approval of the City Engineer.
2. The right-of-way widths and typical sections for the various streets shall conform to the City of Rio Vista Standard Plans 202 and 203.

Cul-de-sac streets shall have a turn-around at the end with a minimum radius on the right-of-way of 50 feet. The reversing curves at the beginning of the turn around shall also be 50 feet radius, see Standard Plans 204 and 205.

In the case where a specific plan for an area has been established, such plan may supersede these standards.

3. The Traffic Index may be changed at the discretion of the City Engineer if traffic warrants a different value.
4. Actual design of horizontal curves shall be based on the design speed of the street as determined by the City Engineer. Use of expanded corners shall be limited to projected low volume residential, commercial and industrial streets and conditions where conformance to minimum horizontal length of centerline radius is not practical, and shall be subject to the approval of the City Engineer.
5. Sidewalk width shall be measured from top back of curb to back of walk for both rolled and vertical curbs, and shall not include width of the curb.
6. Rural roads may only be constructed when providing access to properties zoned for Rural or Agricultural uses with a minimum one-acre lot size. They shall be dealt with on case-by-case basis.
7. An intersection curb return radius may be adjusted, at the discretion of the City Engineer, to accommodate signal timing. Property line radius at intersections shall be consistent with adjacent streets or as otherwise approved by the City Engineer. Where unlike streets intersect, the largest curb return radius shall apply.

3.02 STRUCTURAL SECTION

A. Design

Street sections shall be calculated based on "R" values reported in a "soils

report" and obtained from material gathered from the level of the proposed subgrade using the State of California Department of Transportation design method. The geotechnical engineer may submit for treatment of the subgrade material with lime or cement if suitable soils exist.

3.03 OPEN TRENCHING

A. Moratorium

Open trench may be prohibited on all newly paved and newly overlaid streets and reconstructed streets as determined by the City Engineer. Potholing in these prohibited areas shall only be allowed upon prior approval of the City Engineer.

B. Backfill

Open trenches within City right-of-way shall be backfilled per Standard Detail 101 of these standards.

C. Permit Required

All open trenching within City right-of-way shall be subject to a City Encroachment Permit.

D. Horizontal and Vertical Alignment:

Dry utilities shall be placed to avoid utility conflicts, with sufficient depth and horizontal separation from other utilities, as approved by the City Engineer.

3.04 PARTIAL STREETS

A. Streets shall be improved full width within subdivision boundaries. Off-site streets improvements may be required.

B. Allowances

At the discretion of the City Engineer, partial streets may be permitted along the boundary of a subdivision or other private development where the full right-of-way cannot be dedicated. When permitted, the developer shall, as a minimum, dedicate sufficient right-of-way and construct a full 1/2 street section for the appropriate class of street indicated above along the frontage of the development and 14-foot wide paved roadway with 4-foot wide gravel shoulder along the opposite side. Construction of partial streets shall be limited to residential streets only.

3.05 GEOMETRICS

A. Horizontal Alignment

1. Intersection Angle

Streets shall intersect at right angles if possible. With approval of the City Engineer, 5° from right angle will be allowed. Curved streets shall have at least 50 feet of centerline tangent from the project curb line of the intersection street.

2. Opposing Streets

All streets shall have centerlines directly opposite each other or be separated by at least 150 feet. The minimum distance between streets entering a restricted access street shall be as provided by a specific plan adopted by the planning commission and city council of the City of Rio Vista.

3. Street Curvature

Design of curved arterial and collector streets shall be based on the state of California Department of Transportation Highway Design Manual. The minimum radius of curvature of centerlines shall be 850 feet on arterials and 500 feet on collectors. Minimum radius on other streets shall be 250 feet. There shall be tangent between reversing curves of at least 150 feet on thoroughfare, arterial and collector streets, and 50 feet on all other streets. In special cases, street curvature may be modified with approval of the City Engineer.

4. Cul-De-Sac

The maximum length of a cul-de-sac street, from the center of intersecting street to center of turn around shall be 350 feet. Where longer cul-de-sac streets are required other special conditions may be required by the City Engineer.

5. Curb Return Radii

Residential and non-residential – minimum radius shall be 25 feet.

Commercial – In downtown area the minimum radius shall be 15 feet. In other areas the radius shall be determined by the City Engineer.

Industrial – minimum radius shall be 30 feet.

6. Minor Streets

Minor streets shall be designated that their use by through traffic will be discouraged.

7. Block Lengths

Block lengths shall not exceed 600 feet.

B. Curve Data Requirements

Curve data for street centerline, right-of-way, and face of curb alignment shall be tabulated in a box shown on the improvement plans. Curve data shall include curve length and radius.

C. Gutter Slope

Gutter flow line grades shall have a minimum slope of 0.003 ft/ft. Maximum grades shall be determined by the City Engineer on a case-by-base basis.

D. Curb Returns

The minimum fall around returns shall be 0.20 feet.

E. Cross Slope

Cross slope on all streets shall be as shown on the Standard Details. Any deviation from these standard cross slopes shall be subject to the approval of the City Engineer. For new construction, the maximum cross slope shall be 2%. For reconstruction projects, the maximum cross slope may be increased to 2% - 4% with special approval by the City Engineer.

F. Vertical Curves

The minimum vertical curve length allowable at the intersection of two grades shall be 50 feet. Actual design of the vertical curve shall be based on the design speed of the street and stopping sight distance and shall conform to the State Highway Design Manual unless otherwise specifically approved by the City Engineer. However, vertical curves may be omitted where the algebraic difference in grades does not exceed 1.0 percent.

G. Vertical Control

All vertical control shall be based upon current City, County, or U.S.G.S. datum. Placement of new bench marks as required by the City Engineer shall be based upon City datum. A minimum of two (2) new bench marks shall be set per new development, unless waived by City Engineer.

H. Stopping Sight Distance

The minimum stopping sight distance over any segment of the roadway on any street shall conform to the State Highway Design Manual unless otherwise specifically approved by the City Engineer. No obstructions shall be located closer than 25 feet from the intersection of the right-of-way line extensions unless specifically approved by the City Engineer.

I. Dead-End Length

All new residential, commercial and industrial cul-de-sacs may not exceed 350 feet in length as measured from the centerline of the intersecting street to the radius point of the cul-de-sac bulb. Any longer dead end routes shall be specifically approved by the City Engineer.

Turnarounds (cul-de-sac bulbs) shall be provided on any dead-end road in excess of 150 feet in length as measured from the centerline of the intersecting street. The cul-de-sac radius and bulb transition geometrics shall be as shown on the Standard Details.

J. Additional Lanes

At intersections, additional right-of-way or reduction of landscaping within the median or adjacent to the right-of-way boundary may be required to accommodate additional left-turn, right turn, or through lanes.

3.06 APPURTENANCES

A. Driveways.

The following driveway standards are not applicable to the controlled access highways where access is limited by deed restrictions or other controls.

The number and width of permitted driveways is regulated by the Public Works Department and shall be based on the needs of the parcel served. They shall not be detrimental to the abutting street capacity, safety, and/or efficiency.

Driveway width is measured at the curb line, and includes only the widths of the fully depressed section.

1. Widths

- a. Maximum – Driveway width shall not be greater than 20 feet for residential and 35 feet for commercial and industrial driveways.

The total width of commercial and industrial driveways shall not exceed 60 percent of the frontage.

- b. Minimum – The minimum width of a single residential driveway shall be 10 feet and 25 feet for a commercial or industrial driveway.

2. Distance from curb returns

- a. Intersecting streets – The driveway transition shall not be permitted closer than 25 feet from the projected curb line of the intersection street and no closer than 10 feet from the nearest BCR and ECR.

Commercial and industrial driveways on arterials may be prohibited within 100 feet from the projected right-of-way line of the intersecting street where the intersection is presently or in planned for signalization, or intersection capacity is critical.

- b. Alley – The driveway transition shall be permitted no closer than 10 feet from the projected intersecting alley curb face and no closer than 2 feet from the nearest alley BCR and ECR.

3. Distance from utility or safety devices – The driveway transitions shall clear all public facilities such as electroliers traffic signal standards, utility poles, fire hydrants, and street tress by a minimum of 3 feet. Any relocation of public facilities required to maintain such clearance shall be at the expense of the owner who is installing the driveway.
4. Distance between driveways – A minimum of 4 feet of full curb height shall be maintained between the transitions of adjoining residential driveways.
5. Common use driveways – Common use driveways may be submitted in special cases.
6. Parking lots – Design shall conform to standard details 226-227.
7. Grade – Driveway grades shall be designed to keep the automobile from dragging or “hanging up” on the street or driveway.

B. Parking

For all single-family parcels, at least one on-street parking space, 21 feet in length measured along the face of curb, shall be provided for each single- family lot along the street frontage of the lot. The parking space shall not encroach within any driveway, including the driveway transitions. This requirement does not apply to cul-de-sac bulbs or expanded corner bulbs.

C. Valley Gutters

Valley gutters will not be allowed within the public right of way or public easement unless otherwise approved by the City Engineer.

D. Curb, Gutter, Sidewalk and Driveways

Curb, gutter and sidewalk shall be installed in conformance with the City of Rio Vista Construction Specifications and Standards Plans.

1. Curb and gutter shall be installed along all frontage. Placement shall conform to existing unless otherwise directed by the City Engineer.
2. The minimum widths of sidewalks shall be 4 feet in residential areas. Sidewalk requirements in other areas shall be established on an individual subdivisions basis and shall be approved by the City Engineer.
3. Handicap ramps shall be installed at curb returns at all intersections, and at all other locations specified by the City Engineer.
4. Projections of side yard lot lines shall be clearly marked with a “+” chiseled or sawcut in the concrete at the top edge of the back of sidewalk.
5. All new streets, including residential streets, shall be constructed with curb and gutter conforming to the Standard Details.
6. For retrofit sidewalk construction, any existing improvements located in the sidewalk area including, but not necessarily limited to, joint poles, fire hydrants, street lights, meter boxes, and utility vaults shall be relocated to the back of sidewalk unless otherwise approved by the City Engineer.
7. Where existing curb, gutter, sidewalk and driveways do not meet the current City Standards and are in need of repairs, it shall be the developer's responsibility to remove and replace the necessary curb, gutter and sidewalk. Where curb, gutter, sidewalk and/or driveways are removed, the concrete shall be removed to the nearest expansion, weakened plane or construction joint or sawed at the nearest score line to the minimum depth of 1 ½ inches.

E. Survey Monuments

1. Survey monuments shall be installed at the following locations:
 - a. On the public street centerline at intersections, and at the beginning and end of all curves and at the centerline radius of all cul-de-sac bulbs and expanded corners.

- b. At all subdivision boundary corners and at intersections of the subdivision boundary with public street centerlines.
 - c. At any other locations necessary to enable the subdivision boundaries to be retraced or re-established as determined by the City Engineer.
2. All monuments within the street right of way shall conform to the Standard Details and shall clearly show the registration number of the licensed Civil Engineer or Land Surveyor under whose responsible direction they were placed.

F. Signing, Barricades, and Striping

1. Street names shall be subject to approval by the Planning Commission at the time of tentative Map approval, and shall be shown on the tentative map submitted to the Community Development Department.
2. Street name and all regulatory and warning signs shall be installed by the developer or subdivider at his expense.
3. Permanent barricades shall be installed where improvements cover only a portion of the ultimate development or as directed by the City Engineer. The barricade shall be constructed, erected, painted and signed in accordance with the Standard Details.
4. All striping shall be thermoplastic unless otherwise specified by the City Engineer.

G. Easements

Public utility, sewer, water, drainage, landscaping, fence and all other public easements shall be located as required by the utility companies, these Design Standards, and as directed by the City Engineer.

H. Streetscapes

1. Median sections less than or equal to 4 feet shall be paved or filled with materials subject to approval of the City Engineer. The remainder of the median shall be landscaped.

I. Bike Lanes

1. On-street bike lanes are required as outlined in the Standard Details. The minimum width of bike lanes shall be 6 feet. Bike lane width requirements may increase resulting from design speed as determined by the City Engineer.

J. Emergency Access

1. At least two connections with an existing, improved public street, or with a future street extension approved by the City, shall be provided for all proposed roadways, except when the dead-end length of the roadway does not exceed 350 feet.
2. When the secondary access is to be provided with a future street extension, then a temporary emergency access road or acceptable alternative shall be required as determined by the City Engineer and the City Fire Department. Temporary emergency access roads shall have a minimum paved width of 20 feet and have a minimum structural section of 2" AC over 4" AB. A Knox lock or opticom lock may be required on gates per the City Engineer and the City Fire Department. Gates shall be provided at all points of access to public streets as approved by the City Engineer and the City Fire Department. Said roads shall be contained within an emergency access easement.

SECTION 4 STORM DRAINAGE

4.01 GENERAL

These standards shall provide minimum requirements for the design of Storm Drainage and related appurtenances within the City of Rio Vista rights of way and easements. The design criteria of proposed improvements not included in these standards shall be subject to the approval of the City Engineer.

4.02 STORM DRAIN DESIGN

A. Submittal of drainage calculations

Drainage calculations are required for any new subdivision or development. Submittal of drainage calculations shall include the following items:

1. Hydrology with hydraulic calculations together with assumptions, charts, tables, references, and method uses.
2. A plan preferably 1"=100' scale, showing proposed street system, existing and proposed drainage system, tributary sub-areas (including offsite drainage), and peak flow of all pipes.
3. A plan showing the hydraulic grade line (HGL), the proposed storm drain including slopes and sizes and top of curb profile. Elevations should be shown at all changes in slope of the top of curb.

B. Design Flow

The rational Method ($Q=CIA$) shall be used to determine the quantity of runoff (Q) in designing a storm drain system.

Minimum values for the coefficient of runoff and time of concentration are as follows:

<u>Land Use</u>	<u>C Factor</u>	<u>Tc (Minutes)</u>
Parks	0.20	30
R-1 and R-2 (residential)	0.40	25
R-GA, R-MD, R-HD (Apartments)	0.50	20
Schools and Churches	0.50	20
Commercial	0.80	10
Industrial	0.90	10
 <u>Surface</u>		
Pavement	0.95	
Roofs	0.80	
Compacted Earth	0.75	
Lawn and Open Area	0.20	

A maximum roof to gutter time of 25 minutes should be used for parcels under 1 acre. The acre (A) shall be the tributary drainage area in acres.

The area (A) shall be the tributary drainage area in acres Manning's formula shall be used to determine the relation of design flow, slope, velocity and pipe diameter. The friction factor "N" shall be 0.013 for all types of pipe.

The storm frequency to be used in drainage system design will be the storm frequency applicable for the design point under consideration. The following guidelines give a general rule for determining applicable design storm frequency. The actual storm frequency used will be specified at the discretion of the City Engineer.

1. 10 year storm

The drainage system for the 10 year storm is to be designed to minimize inconvenience, protect against minor damage, and reduce maintenance costs.

Improvements to be designed for the 10 year storm shall generally include local drainage facilities for residential, commercial, office, and industrial development. This will almost always include all closed conduit design and minor, channel sections.

2. 50 year and 100 year storm

The drainage system for the 50 and 100 year storms are to be designed to protect against loss of life or substantial property damage. Improvements requiring 100 year design capacity are open channels and detention basins. Minor channels

and closed conduit systems shall also meet the requirements for the 100 year storm as specified in these standards.

4.03 HYDRAULICS

A. General

1. All storm drain pipelines and open channels shall be designed for the above specified frequencies. For the 10-year frequency storm, storm drain pipelines shall be designed without static head at all entrances unless specifically permitted by the City Engineer. In no case will less than one (1) foot of freeboard be permitted between top of curb and hydraulic gradient of the 10-year frequency design flow.
2. An overland release path for flows generated by a 100-year frequency storm shall be clearly delineated on the plans. Structural pad elevations shall be constructed a minimum of one foot above the highest top back of curb elevation across property frontage on public streets.

B. Design Criteria

The following criteria shall be followed in all hydraulic computations unless otherwise approved in writing from the City Engineer.

1. Manning's formula shall be used to compute capacities of all open and closed conduits other than culverts.
2. King's formula shall be used to compute capacities of all culverts. (Refer to King's Handbook of Hydraulics and California Department of Transportation nomograph for the solution of King's formula).
3. The "n" values to be used in Manning's formula shall conform to the following:

A roughness coefficient, $n = 0.015$ is used for sizing conduits when no allowance is made for minor losses (head loss at inlets, bends, junctions, expansions, etc.). If minor losses are accounted for, a roughness coefficient, $n = 0.013$ or per manufacturer's recommendations may be used.

4. Min. Inside Diameter - 12 inches
5. Min. Velocity - 2 feet per second when flowing half full regardless of the slope of the hydraulic grade line. Pipes with lower velocities shall use available fall and have the specific approval of the City Engineer.
6. Max. Velocity -Based on pipe or channel conditions and available head. (Generally shall not exceed 10 feet per second for pipelines).

7. The Engineer, in the design of the system, shall account for all losses in head at junctions, bends, manholes, entrances, and outlets, and at any other location where a change in direction or restriction to flow occurs which would tend to create a loss in available energy when required by the City Engineer.

4.04 ALIGNMENT

- A. Pipelines for storm drainage shall be straight between manholes, junction boxes, and/or catch basins except under the following conditions:
 1. The inside pipe diameter is equal to or greater than 24 inches.
 2. Minimum radius of curvature is equal to or greater than 200 feet. In no case will the radius of curvature be less than the manufacturer's recommendations for the particular pipe size under consideration.
- B. Drainage pipelines shall be located in the street whenever possible. The location of storm drainage pipelines in new streets shall be two (2') feet north or west of and parallel with the centerline of the street, unless otherwise approved by the City Engineer. Meandering and unnecessary angular changes of pipelines shall be avoided. Angular changes in alignment shall be no less than 90 degrees with the downstream section of the storm drain main.
- C. All laterals intersecting with the mainline or manhole shall have an alignment that provides an angle of intersection with the downstream section of the storm drain main of no less than 90 degrees.
- D. Joint deflection shall not exceed 80% of the manufacturer recommendations.
- E. When a change in pipe diameter occurs, the top-of-pipe elevations of the inflow and outflow pipes shall match whenever possible unless specifically approved by the City Engineer. This does not apply to catch basin laterals.

4.05 COVER REQUIREMENTS

- A. All storm drain pipe alignments shall be designed to allow a minimum of 3 feet of cover as measured from the top of finished grade to the inside top of pipe in residential streets and 3.5 in all other streets. If, for sound engineering reasons, 3 feet of cover cannot be obtained, the pipe shall either be encased in concrete or provided with a concrete cover as specified by the City Engineer.
- B. Catch basin laterals that have less than 18 inches of cover shall be encased in concrete.
- C. A minimum vertical clearance of 3 inches shall be maintained between a sanitary sewer or other underground utility.

- D. When crossing a water main it is desirable that the sanitary sewer be installed below the water main with a clearance of 12 inches. When a crossing is necessary, State Health Department Standards shall be adhered to.

4.06 Pipe

- A. The minimum size for storm drain shall be 12” diameter. All catch basin laterals shall have a minimum diameter of 12”
- B. The following standard pipe materials shall be used for storm drain construction and shall conform to the appropriate American Society of Testing and Materials (ASTM) and American Water Works Association (AWWA) specifications (latest revision)

<u>Pipe Material</u>	<u>Specifications</u>
Concrete Pipe	ASTM C14
High Density Polyethylene pipe	ASTM F2306, F2648
Reinforced concrete pipe	ASTM C76

**HDPE pipe is not allowed for a diameters greater than 15 inches unless specifically approved by the City Engineer.

- C. Cast-in-place concrete pipe, 36” and larger, may be used when specifically approved by the City Engineer. Cast-in-place pipe will not normally be permitted in existing streets.
- D. Storm drain joints shall be designed and installed to minimize infiltration and to prevent the entrance of roots throughout the life of the system.
- E. Joining of pipe sections of unlike materials shall be accomplished using approved band seals or couplers. Other joining methods shall not be used unless approved by the City Engineer.

4.07 APPURTENANCES

- A. Manholes
 - 1. All storm drain manholes shall be constructed in accordance with the Standard Details.
 - 2. Manholes shall be located at junction points, changes in gradient, changes in conduit size and on curved alignments at the BC and EC of the curve and at no more than 300-foot intervals along the curve. For straight alignments, the spacing of manholes shall not exceed 500 feet for 12” to 33” pipe and 750 feet for 33” pipe and over.
 - 3. Whenever, at manholes, a change in the size of pipe, or a change in the alignment of 20 degrees or more occurs, the flow line of the incoming pipe shall

be a minimum of 0.12 feet above the flow line of the outgoing pipe. The invert elevations in and out of the proposed manhole shall be shown on the improvement plans.

B. Junction Boxes

Junction boxes constructed on storm drainage conduits greater than 60 inches in diameter shall be of special design requiring approval by the City Engineer.

C. Saddle Manholes

All saddle manholes shall be constructed in accordance with the Standard Details. Saddle manholes will be allowed to be constructed on storm drain conduit 36 inches or greater in diameter provided that no junction exists with any other storm drain conduit at the manhole as determined by the City Engineer.

D. Catch Basins/Inlets

Catch Basins/Inlets shall conform to the Standard Details. Catch basins/inlets shall be designed and spaced such that they intercept and fully contain the 10- year storm. Catch basins/inlets shall be installed so that the length of flow in the gutter does not exceed 600 feet. All catch basin/inlets shall be stamped with a Drainage Inlet Marker," Medallion type, per Caltrans Std. D71. It should read "No Dumping, Drains to River."

E. Siphons

Inverted siphons will not be permitted.

F. Valley Gutters

Valley gutters will not be permitted to cross any streets, unless approved by the City Engineer.

G. Subdrainage

Subdrain facilities shall be provided when required by the City Engineer.

H. Box Culverts

Shall be required when specified by the City Engineer and designed on an individual basis.

I. Headwalls, Wingwalls, Endwalls, etc.

Shall be considered on an individual basis, and in general, designed in accordance with Section 51 of the State Standard Specifications.

J. Drainage Pump Stations

May be permitted on an individual basis with the written approval of the City Engineer.

K. On-Site Drainage

All developed areas shall connect on-site drainage into City of Rio Vista drainage system. A stormwater cleaning/filtering unit is required.

L. Private Storm Drain Connections

The minimum size for private storm drain connections shall be 12 inch diameter.

The pipe shall conform to the storm drain pipe specifications. A reasonably accessible structure shall be provided on the private storm drain connection within 10 feet of the street or alley right of way.

Private storm drain connections shall be tied into alley or street catch basin or manholes.

M. Contributing Drainage Areas

Areas not shown as future development in the general plan shall be considered as undeveloped. The Solano County Flood Control Design Criteria handbook may be used in computing runoff from these areas. All other areas shown as developed in the future, shall be addressed under these standards.

N. Retention Basins

Retention basins shall only be allowed with special permission of the City Council after review and report by the City Engineer.

4.08 OPEN CHANNELS

A. Definition

1. For the purposes of these Design Standards, a ditch shall be classified as an open channel when its capacity exceeds 25 cfs.

B. Design Criteria

1. Drainage may not be conveyed through a development in open channels without the written approval of the City Engineer. Open channels shall be designed in accordance with the following:
 - a. Velocity range shall be 2.5 to 6.0 feet per second in unlined open channels and 3.0 to 12.0 feet per second in lined open channels.
 - b. Channel lining shall be either finished concrete, sacked concrete, or doweled and sacked concrete. The minimum weight of sacked concrete shall be 60 pounds.
 - c. All open channels shall be designed to carry the 100-year frequency flood.

Per Section 4.02, the hydraulic grade line of the 10-year and 100-year storms shall be calculated and plotted on all channel profiles. All computations,

including a narrative of the design shall be clearly documented and submitted to the City Engineer for approval.

- d. Freeboard shall be a minimum of 1.0 feet for the 100-year event and comply with the latest FEMA regulations.
- e. Side slopes shall be 3 feet horizontal to 1-foot vertical or flatter and the minimum bottom width of the channel shall be twice channel depth.
- f. Profile of existing channels for a minimum of 1,000 feet at each end of the development shall be shown on the construction plans to establish an average profile grade.
- g. Easement widths shall not be less than the width of the channel plus 4 feet on one side and 14 feet on the opposite side. A twelve-foot wide gravel road, serviceable for year around use, shall be constructed along one side of the channel.
- h. Special headwalls, endwalls, reinforced concrete transitions to culvert crossings, rip-rap, concrete aprons, energy dissipators, and other hydraulic devices shall be installed where required. All such devices shall be shown on the plans and approved prior to construction.

SECTION 5 SANITARY SEWERS

5.01 GENERAL

A. Submittal Requirements

1. Sanitary sewer system design within a developing area shall conform to the General Plan, Master Sewer Plan, and any applicable Specific Plan of the City of Rio Vista and include provisions for size and capacity to adequately convey all domestic and industrial waste that can be reasonably anticipated under conditions of full ultimate development. Engineering calculations to support the sewer system design shall be submitted to the City Engineer for approval. The calculations shall include:
 - a. Map indicating service area within the sewer system including any future contributing development with projected land use, zoning, and any physical features contributing to the sewer system design.
 - b. Sanitary sewer waste volumes either existing or proposed within the service area of the system.
 - c. Size and slope of each pipe between appurtenant structures.
 - d. Invert/rim elevations of each pipe and appurtenant structure.
 - e. Storm water shall not be connected or discharged into a sanitary sewer. Industrial waste maybe connected or discharged into a sanitary sewer with approval of the City Engineer. All installations shall be made in conformance with Construction Specifications approved by the City Engineer.

5.02 PIPE DIAMETER

A. Public Mains

1. The minimum size of any new public sewer main shall be 6 inches in diameter.

B. Residential Services

1. The minimum lateral size is 4 inches where grade requirements can be met and the intended use is to serve single family or duplex residences.

C. Non-Residential Services

1. Six-inch or larger laterals shall be installed where intended use is industrial, commercial or greater than single family or duplex residential flows.

5.03 DESIGN

A. Flow Calculation

The design sanitary sewer flow shall be computed using the following formula:

$$QD = QP + I$$

Where: $QD =$ design flow (eq.5-1)

$I =$ Infiltration and inflow

$QP =$ peak flow

And: $QP = Q_{ave} * PF$ (eq. 5-2)

Where: $Q_{ave} =$ Average Flow

$PF =$ Peaking Factor

1. Residential Flow

a. Average flow (Q_{ave}) shall be based upon the following criteria:

1. 3.0 persons per single family dwelling unit
2. 2.5 persons per multi family dwelling unit
3. 100 gallons per person per day

b. Peaking Factor (PF) shall be 3

c. Infiltration and Inflow (I) shall be added to the design flow at the rate of 1000 gallons per acre. If a project contains an unusually high footage of sewer pipe, the City Engineer may increase the infiltration rate.

2. Non-Residential Flow

a. Average Flow (Q) shall be based upon the following criteria:

1. Other Commercial 1500 gpad*
2. Prof. Office/Bus Park 1500 gpad

3. Recreation 500 gpad
4. Schools 4.25 gpd/student
5. Light Industrial 2000 gpad
6. Heavy Industrial (case-by-case basis)

* (gallons per gross acre per day)

NOTES:

1. High volume generators such as restaurants shall be considered on a case-by-case basis.
 2. Multi-story structures will be considered on a case-by-case basis.
- b. Peaking Factor (PF) shall be based upon the following criteria
1. Industrial = 2
 2. Non-Industrial = 3
- c. Infiltration & Inflow (I) shall be the same as for residential flows.

B. Pipe Capacity

1. Manning's Formula [$Q = A (1.49/n) R^{2/3} S^{1/2}$] shall be used to determine pipe capacity. The "n" value shall be 0.013 or the pipe manufacturer's recommendation. Manning's "n" values, which are less than 0.013 shall require City Engineer approval and shall only be allowed if minor losses are accounted for.
2. All main sewers shall be sized to carry the design flows at a maximum of 70% of pipe capacity.

C. Velocity

1. Sewer velocity shall be equal to or greater than 2 feet per second for all sewers when flowing full. Maximum velocity should be 10 fps.

D. Pipe Cover and Clearances

1. Minimum pipe cover and clearance shall be maintained in the design of sanitary sewers. If certain conditions exist which make it impractical to meet the minimum cover and clearance requirements, the conditions and locations shall be specifically noted above the sewer profile on the plans. Each location not meeting the minimum cover and clearance requirements will require special approval. Any planned condition being specially approved with less than

minimum cover will require special pipe, bedding and/or backfill as approved by the City Engineer.

2. Main and trunk sewers shall have a minimum depth of 4 feet as measured from the top of the pipe to the finished grade.
3. Laterals shall have a minimum depth of 3 feet from the top of the pipe to finished grade.
4. Pipe shall be laid with a minimum of 12 inches vertical clearance below water lines and 6 inches clearance from all other improvements and utilities, unless otherwise approved by the City Engineer. Other utilities shall not, under any circumstances, be installed immediately over and parallel to any sanitary sewer line installation.

E. Horizontal Alignment

1. Sewer mains and trunks shall be located 12 feet north or west of and parallel with the street centerline unless otherwise approved by the City Engineer.
2. Alignment of sanitary sewer mains shall be straight between manholes. Whenever it is essential that a curved alignment be used, a minimum radius of 200 feet shall be required, but shall be greater whenever possible. The radius and delta of all curves shall be indicated on the plans adjacent to the curve.
3. The deflection in the joint between any two successive pipe sections shall not exceed eighty (80) percent of the maximum deflection as recommended in writing by the pipe manufacturer.
4. Minimum horizontal separation between parallel sewer and water mains shall be 10 feet.

F. Lateral Sewers

1. Laterals are those portions of the sewer system between the sewer main and the portions of the sewer maintained by the property owner. The usual location of the line separating responsibility of the City and property owner is the back of sidewalk cleanout. In all cases, City maintained sewer lines will lie in a street right-of-way or dedicated public easement. In all new subdivision work, the house lateral line and cleanout from the sewer to the property line shall be installed at the time the sewer main is constructed. Each lateral line shall be referenced to the Improvement Plan stationing.
2. All laterals, from property line or edge of easement to the point of connection with the main line or a manhole shall have an alignment that provides an angle of intersection with the downstream section of the main sewer of no less than 90 degrees.

3. The maximum deflection at any one point in a lateral, not including fittings at saddle or wye connection to main sewer or at angle points having cleanouts, shall be 22-1/2° (1/16 bend) and any two consecutive deflections (bends) shall not be less than 2 feet apart.
4. For single family and duplex uses, cleanouts shall be provided on the lateral sewer at the back of sidewalk as shown on the Standard Details.
5. For sewer laterals 6 inches and larger in diameter, manholes shall be provided at or near the street right of way line.
6. Sewer laterals shall be installed with a minimum of five (5) foot horizontal separation from water services for all single family and duplex uses.
7. Laterals shall connect to the main at manholes whenever possible. Laterals for residential properties located within cul-de-sacs shall be connected at a manhole.
8. A single sewer connection shall not serve more than one parcel. Each individual parcel shall have a separate sewer connection.

G. Pipe

1. The following standard pipe materials shall be used for gravity flow wastewater line construction and shall conform to the appropriate American Society of Testing and Materials (ASTM) and American Water Works Associates (AWWA) specifications (Latest revision).

<u>Pipe Material</u>	<u>Specifications</u>
PVC – SDR35, SDR26	ASTM D3034, F679
Ductile iron pipe w/polyethylene lining and encasement	ASTM A746, ASTM D1248, AWWA C105

*Lining shall be 30 mil minimum, encasement 8 mil minimum.

2. Joints and fittings shall be selected and installed to minimize infiltration and to prevent the entrance of roots throughout the life of the system. Ductile Iron pipe joints and fittings shall conform to AWWA C110 or other approved joint for wastewater applications. Joints for PVC pipe shall be bell and spigot conforming to ASTM D3212.
3. Joining of pipe sections of unlike materials shall be accomplished using approved band seals or couplers. Other joining methods shall not be used unless approved by the City Engineer.

H. House service

The minimum house service shall be 4 inch and shall be installed in conformance with Standard Detail 401.

I. Appurtenances - Manholes

1. Along straight alignments of mains, the maximum spacing for manholes shall be 400 feet for pipe 10 inches and under and 600 feet for pipe 12 inches and over. Where the location of two manholes is determined by intersecting lines, the distances between intervening manholes shall be approximately equal.
2. Sewers constructed on curved alignments where 200' feet < radius < 400' feet shall have additional manholes placed per the following criteria:
 - a. Where curve length < 50' feet; no additional manholes required
 - b. Where 50' feet < curve length < 150' feet; a manhole shall be required at either the BC or the EC
 - c. Where curve length > 150' feet; a manhole shall be required at the BC and the EC and at 300 ft intervals along the length of the curve.
3. Whenever, at manholes, a change in the size of pipe, or a change in the alignment of 20 degrees or more occurs, the flow line of the incoming pipe shall be a minimum of .12 feet above the flow line of the outgoing pipe. The invert elevations in and out of the proposed manhole shall be shown on the improvement plans.
4. Manholes shall be used at the termination of all sewer mains including cul-de-sacs. Cleanouts may be installed at the upstream end of mains, which are proposed to be extended in the future on an approved development plan.

J. Unusual Design

1. Special design of sewer force mains, siphons or other unusual features or structures shall be subject to the approval of the City Engineer.

5.04 LIFT STATIONS AND FORCE MAINS

A. Requirements

Where extreme hardship conditions prevail, and a substantial area cannot be sewerred by gravity sewers in accordance with these standards, a sewage pumping station may be installed. No sewer design shall rely on a pumping facility without prior approval of the City Engineer.

B. Lift Station Design

Lift stations, where allowed, shall incorporate the following features:

1. Pumps or other devices shall be duplex. Minimum desirable size is 4 inches. Maximum velocity in suction is 5 ft/sec. Pumps shall be capable of passing 3 inch solids.
2. Capacity shall be provided to handle ultimate peak flow from the tributary area with the largest pump out of service. Stage installation of pumps is allowed providing space is provided for future installations. Where slide mount submersible pumps are used, a duplex installation of 100% design capacity may be used if a spare pump assembly is supplied to the City complete. Where design flows exceed 1.0 cfs, a low flow pump shall be provided in addition to the design rated pumps. The low flow pump shall have a capacity of 5%-10% of the design flow and shall operate as the lead pump.
3. Access to pump station and to wet well shall be provided with locks keyed to City Master.
4. A lifting loop over pump/motor, or similar provisions for removal of pump shall be provided.
5. Pump station and wet well shall be lighted.
6. The wet well rim electrical panel shall be above the 100 year flood elevation.
7. Pump curves, operating voltage, and phasing, horsepower, etc. shall be in accordance with approved submittal of Caltrans Standard Specifications.
8. Submersible pumps shall be capable of running air without damage. Moisture sensing circuit breakers in terminal changer shall be incorporated into submersible pumps.
9. A NEMA, weatherproof outdoor enclosure shall be provided for controls. Electric service shall be provided by underground conduit to the utility service pedestal.
10. Lift station and SCADA system controls shall be approved by the City Engineer and shall be by solid state programmable controller with sensor (or equal) with LED digital readout with purge and clean capacities and automatic pump alternating. A standby battery and charger shall be supplied. The battery is to be able to operate the controller for two weeks with the external power source removed. An adjustable time delay before any restart shall be incorporated which allows delays from 1 to 10 minutes. Switches for manually operating the pumps shall be included.

11. An on site alarm with exterior lights and horn with battery backup, including switchable power failure, and low water and high water sensors shall be provided.
12. An automatic telephone dialer and message capability for all alarms shall be installed.
13. Each sewer pump shall have gate valve and check valve on the discharge piping.
14. Access and work area of pump stations shall be paved with minimum 2" AC on 4" AB.
15. A six (6) foot high chain link fence or masonry wall approved by the City Engineer shall be constructed to enclose the pump station.
16. A means of dewatering force mains shall be provided.
17. The lift station shall not be in City road right-of-ways except with permission from the City Engineer.
18. The interior of the structure, all machinery, piping, and exterior below grade shall be painted.
19. The City shall be provided with three complete sets of manufacturer's brochures, technical data, O & M manuals, schematics, wiring diagrams, etc., for all equipment and controls.

C. Structural

Structures shall be reinforce concrete, fiberglass, fusion epoxy coated or galvanized steel. In residential areas, structures shall be below ground. Provide a hatch suitable for the removal and replacement of major equipment components. Hatches shall be spring loaded (Bilco type) with metal provided.

D. Mechanical and Piping

All design shall satisfy the minimum requirements of the State Health Code. A reduced pressure principle device is required on all domestic water connections. A 1" metered connection is to be provided adjacent to the station. Provide an automatic sump pump (slope floor to pump) with check valve in discharge pipe wet well. Provide standby pumping capacity equal to the largest single unit. Make provisions for standby emergency power connection for use during power outages. Sump pumps and air blowers shall be easily removable for maintenance.

E. Electrical

All electrical installations shall comply with the National Electric Code and Division of Industrial Safety requirements, and City Code. Use enclosed prefabricated electrical panels mounted above ground level outside the pump station. Provide running time meters for all motors (use reset type). Provide explosion-proof electrical appurtenances below ground or an approved type disconnect and time delay. Provide separate blower system with in all electrical panels located below ground. Provide an approved type alternator and float switches. A manual switch shall be mounted at motor height. Adequate lighting and electrical outlets shall be provided. Outlets shall be mounted at motor height. Color code all wiring and piping. (National Standard Coding.)

F. Force Main Design

Force Mains shall be designed in accordance with good engineering practice. Maximum velocity shall be 10 ft/sec. Minimum velocity shall be 2 ft/sec. Preferred pipe material shall be PVC C900, Class 150, DR18 pipe and shall be green or brown.

5.05 TESTING OF SEWER SYSTEMS

- A. Prior to acceptance, all Sanitary Sewers are to be balled and flushed, pressure tested, mandrelled and video inspected. The pressure test shall be 4 lbs. for 4 minutes with no loss.

5.06 OFFSITE IMPROVEMENTS

The subdivider may require to build improvements or to pay a fee established by the City for the development of sewage disposal facilities or for the improvement of any existing sewage disposal system and the construction of transmission lines from the proposed improvements to the site of disposal.

SECTION 6 WATER SYSTEM

6.01 GENERAL

System Description

The existing City of Rio Vista water system supplies treated water within the developed areas of the City. It consists of water wells, storage tanks, booster stations and several miles of pipe ranging from 4" to 12".

6.02 DESIGN REQUIREMENTS

A. General

Water system design within a development area shall conform to the General Plan, Master Water Plan, and any applicable Specific Plan of the City of Rio Vista, and shall be capable of transmitting and distributing adequate flows and maintaining sufficient pressures based on anticipated conditions of full ultimate development. All improvements including extensions, replacements, and repairs shall conform to the requirements of the Uniform Plumbing Code, the Uniform Fire Code, California Health & Safety Code, American Water Works Association Standards, the Water Code of the City of Rio Vista, these Design Standards, Standard Construction Specifications and Standard Details of the City of Rio Vista.

B. Layout of Mains

1. The distribution system, whenever possible, shall employ the "Gridiron System" of water circulation so as to allow pressure equalization. Dead end water mains shall require specific approval by the City Engineer. In no case shall the dead end length of water mains exceed 500 feet.
2. All water pipelines designed for the transmission or distribution of domestic water supply shall be constructed and installed within public streets unless such construction or installation is determined to be impractical by the City Engineer. All water lines that lie outside of public streets shall be in a water easement or public utility/service easement (PUE/PSE).
3. The location of the water main in any street shall be ten (10') feet from and parallel with street centerline on the southerly or easterly side of the street unless otherwise approved by the City Engineer.
4. No case shall there be less than 10 feet horizontal clearance to a sanitary sewer, storm drain, or industrial waste line.
5. Curved water mains are not allowed in curved streets when curvature does not exceed manufacturer's recommendations.

C. Sizes

The minimum size water main shall be 8 inches in diameter. In all cases, water mains shall be of sufficient size to meet fire flow requirements or as directed by City Engineer.

D. Vertical Alignment

1. The minimum cover on water mains shall be 42 inches. When crossing a sanitary sewer or storm line it is desirable that the water main be installed above with a clearance of 12 inches. The minimum vertical clearance of 6 inches shall be maintained between a sanitary sewer or storm drain.
2. The invert elevations shall be shown on all water main improvement plans.
3. All high points within the system shall be located at fire hydrant locations insofar as practicable.

E. Pipe Materials

1. Allowable materials shall be as specified in the following table.

<u>Pipe Material</u>	<u>Specifications</u>
PVC, C900, CL150, CL200	AWWA C900
PVC, C905, CL165	AWWA C905
Ductile Iron Pipe with cement lining and polyethylene encasement	AWWA C151 AWWA C104, C105

*Ductile Iron pipe shall have a minimum working pressure of 150 psi.

2. When a ferrous material (i.e.; ductile iron) is used for a new water line, the City Engineer may require that the soil within the vicinity of the new water line be tested for corrosive potential. If it is determined that the soil is corrosive to the material being placed, the new water system must be protected by a corrosion control system. The corrosion control system must be designed by a licensed corrosion engineer and shall be submitted to the City Engineer for approval.

F. Valves

1. The distribution system shall be equipped with a sufficient number of valves so that no single shutdown will result in shutting down a transmission main, or necessitate the removal from service a length of pipe greater than 500 feet. Additionally, in no case shall more than two fire hydrants be removed from service. The valves should be so located that any section of main can be shut down without going to more than three locations to close valves. Gate valves shall be Mueller 2360 series resilient wedge valves or approved equal.
2. All tees shall have three valves.
3. All crosses shall have four valves.

4. Valves, incorporating a blowoff device, or a fire hydrant, shall be installed at the terminus of all dead-end water mains.
5. A valve shall be installed on services immediately off the main for services 4” inches and greater in diameter.
6. Air Release valves shall be installed at high points in the vertical alignment of all water mains. The vertical alignment of water mains shall be designed to minimize this requirement.
7. Blow-off valves shall be installed at all dead ends of water mains.
8. Bollards or markers shall be installed at all valves and fittings when located in unpaved areas.

G. Fire Hydrants

1. Fire Hydrants shall be supplied from the largest available main.
2. Fire Hydrants shall be fed from 2 directions unless specifically approved by the City Engineer and Fire Chief.
3. Fire hydrant spacing and distribution shall be determined as follows:
 - a. The maximum hose lay shall be 200 feet in high density, commercial, industrial zoning or high-value districts, with a maximum spacing of 400 feet.
 - b. The maximum hose lay shall be 250 feet in residential areas with maximum spacing of 500 feet.
 - c. On divided streets, planned divided streets or highways, the above spacing shall apply to both sides of the street.
 - d. A fire hydrant shall be located within 200 radius point of all cul-de-sacs.
 - e. Distribution main, fire hydrants and fire flow requirements shall conform to the recommended Standards of Insurance Services Office. Refer to “guide for Determination of Required Fire Flow” published by Insurance Services Office.
4. Fire flow and fire hydrant distribution, including the number of hydrants required and specific locations, shall be approved by the City Engineer and Fire Chief.
5. Fire hydrants shall be class 960 or approved equal and shall be installed in conformance with Standard Details 507 & 508.

H. Services

1. In all new subdivisions, the residential service line shall be located a minimum of 5 feet from the side yard property line. Service lines from the water main to the property line shall be installed at the time the main is constructed to avoid frequent cutting of the street, unless otherwise approved by the City Engineer. They shall be polyethylene pipe conforming to applicable standards.
2. Service lines to existing buildings shall be installed so as to make the most direct connection to the existing structure.
3. A single domestic service connection shall not serve more than one parcel. Separate parcels shall be supplied water through separate service connections.
4. More than one domestic service shall not be supplied to a single property for the purpose of avoiding water connection charges. Water meters shall be sized consistent with the water service size. Backflow prevention devices shall be sized as necessary.
5. Minimum service line diameter to single family residences shall be 1 inch. Services to schools, commercial, industrial or multi-family units shall be sized according to demand. 2-1/2 inch or 3 inch diameter line sizes shall not be allowed within public right-of-way or easements.
6. For commercial, industrial or multi-family developments, a separate service line must be utilized for fire and domestic services.
7. For public irrigation systems, the City may consider the installation of a turbo type meter and/or varying meter and line sizes.

I. Cross Connections

1. Attention is directed to Title 17, Chapter V, Sections 7583 to 7622, inclusive, of the California Administrative Code, regulating the construction of cross connections between drinking water systems and other sources of water. All construction shall be in strict compliance with said regulations and all applicable City Ordinances. The addition of a backflow prevention device to any water system supplying an automatic fire sprinkler system shall cause the automatic sprinkler system to be recalculated. It is the responsibility of the property owner to ensure that all sprinkler system requirements are met after installation of the device.

2. Backflow prevention devices shall be installed on all commercial, industrial, multifamily fire, domestic, and irrigation services as shown in the Standard Details.

J. Anchors

Concrete anchors, thrust blocks, or mechanical joint restraints, if approved by the City Engineer shall be provided at all bends, behind tees, fire hydrants, crosses (which are valved in such a manner that they can be used as tees) and valves, as shown in the Standard Details.

K. Fittings

Standard approved fittings shall be used at all bends of 11-1/4 degrees and greater. Deflections shall not exceed 80% of manufacturer's recommended maximum values.

L. Cover Requirements

Water mains and services shall be installed at a depth which will provide a minimum of 42 inches from the top of the pipe to finished grade.

SECTION 7 STREET LIGHTING

7.01 GENERAL

A. General Requirements

These specifications shall cover the design and installation of street lights. The design and installation shall conform to these Design Standards, and the Standard Details.

B. Submittal Requirements

1. The Consulting Engineer shall show the existing and proposed street lighting system on separate street light plans of the project improvement plans.

The plans shall include the following items:

- a. Location of electroliers.
 - b. Location of service points.
 - c. Location of pull boxes.
 - d. Intensity of luminaries.
 - e. Conduit size, lengths, and runs.
 - f. Wire size, lengths, and runs.
 - g. Mounting height and arm length.
 - h. Service Voltage and wiring diagram.
2. The Consulting Engineer shall submit two (2) copies of the street light plans to the City for preliminary review. The Consulting Engineer shall then obtain service locations, service voltages and identification numbers from the Pacific Gas and Electric Company (PG&E).

After the Consulting Engineer receives the service locations, he shall determine the wire size and length of each conduit run. These items may be shown in tabular form or denoted next to each conduit run on the plans.

The cost for all PG&E services shall be paid for by the developer or contractor. This shall include the PG&E connection charge for energizing street lights.

7.02 DESIGN

A. Spacing, Intensity and Pole Heights

Street lights shall have the maximum spacing, distribution, mast arm length, intensity and pole heights according to the type of street on which they are to be installed.

Light spacing for streets with a width of 60 feet or more is based on a one -sided arrangement and that spacing for narrower streets is based on a two -sided arrangement. The one-sided spacing arrangement is a system whereby the street light spacing relates to the distance between street lights all on the same side of the street. The two -sided arrangement relates to the distance between street lights taking into consideration the street lights on both sides of the street. The actual constructed street width shall be the controlling factor for determination of street light spacing rather than the street classifications (arterial, collector, etc.)

1. The following steps shall be taken to determine the appropriate spacing and location for street lights.
 - a. Identify the nearest intersections each way from the street light location being planned. Determine the location of the street lights at the intersections in conformance with the design standards.
 - b. Determine the distance between the adjacent intersection requiring lights and then divide the distance into equal spaces.
 - c. Compare the light locations to intersecting property line, driveways and other obstructions as follows:
 1. If the location falls close to a property line and it can be adjusted to the property line while staying within the maximum spacing allowed, then the adjustment should be made.
 2. Generally, street lights should be situated at intersecting property lines for residential lots and parcels with minimal frontage (75 feet or less). The light spacing may have to be unbalanced, with additional lights being added to attain this and still comply with the maximum spacing allowed.
 - a. Variations to these requirements may be approved on an individual basis by the City Engineer.

B. Location of Street Lights

1. On streets with separated sidewalks, street lights shall be located two (2) feet behind the face of curb.
2. On streets with monolithic curb, gutter, and sidewalk, street lights shall be located at the back of sidewalk. The edge of the pole foundation shall meet the back of sidewalk.
3. Where there is only curb and gutter, the street light shall be located two (2) feet from the face of curb.
4. In cul-de-sacs, a street light shall be located within the bulb area.

5. For intersection lighting refer to Standard Detail #603.
6. Street Lights shall be placed on the outer edge of curves.
7. Street Lights shall be placed adjacent to bus stop shelters.

C. Lighting Distribution Pattern

1. All street lighting shall be as listed in the Standard Details.

D. Pull Boxes

1. Pull boxes shall be spaced at a maximum of 200 feet.
2. One pull box shall be located next to each electrolier unless there is a secondary electric service whose pull box is located within 8' feet of the electrolier and such electrolier is singularly serviced.
3. One pull box shall be located at each side of all street crossings.
4. Pull boxes shall be placed immediately behind the sidewalk in sidewalk areas or 3-5 feet behind the back of curb in non-sidewalk areas.
5. Pull boxes shall be located at any angle point greater than 45 degrees.

E. Ballasts

All street lights shall have a regulator type ballast.

F. Voltage Drop Calculations

Voltage drop calculations shall be submitted whenever four (4) or more lights are served from a single source point. The calculations shall be done in accordance with the Standard Details. The maximum permissible voltage drop is 5%.

G. Photocells

A photocell shall be included on each separate luminaire.

H. Service

All street light systems shall have underground service provided. Service points shall be provided within a utility easement immediately adjacent to or within the right-of-way and shall be open and easily accessible to the street frontage.

1. Types of service are as follows:
 - a. A direct underground service consists of one or two lights being served from a single service point. The service point may be in the form of a service pullbox installed by the Developer, which is connected to a secondary splice box provided by PG&E.

- b. A multiple service is three or more lights being served from a single service point. The service point shall be in the form of a service pullbox installed by the Developer. Multiple systems shall have a State Standard Type III-AF service equipment enclosure (Anodized Aluminum Cabinet) located adjacent to the service point.

I. Conduit Fill

- 1. The National Electric Code limits the portion of the conduits cross section that can be occupied by conductors to the following:
 - a. One (1) Conductor - 53%
 - b. Two (2) Conductors - 31%
 - c. Three (3) or more conductors - 40%
- 2. As a practical limit projects for new construction/installation should be designed with 26% of the conduit x-section occupied by conductors. Standard Detail #609 lists conductor sizes and available conduit area.

J. Conduit Locations

- 1. In separated sidewalk locations, conduit shall be placed under the front edge of the sidewalk closest to the street.
- 2. In monolithic curb, gutter and sidewalk locations, conduit shall be located under the back edge of sidewalk farthest from the street.

SECTION 1 GENERAL INFORMATION

1.01 PURPOSE

This Division specifies design and construction requirements for site improvements constructed on private property within the City of Rio Vista.

The purpose of applying the City of Rio Vista Standard Specifications to private site developments is to ensure that minimum standards of construction are maintained to protect the health, safety, and general welfare of the public. These standards are intended to minimize the potential of: contamination to the potable water system by cross-connections; ground water intrusion into the sanitary sewer and storm drainage systems; ground water contamination resulting from leakage of sanitary sewer systems; damage to habitable structures caused by flooding; and structural failure of pavement area subjected to vehicle loads.

SECTION 2 DESIGN REQUIREMENTS

2.01 PAVEMENT AND STRUCTURAL SECTION REQUIREMENTS

- A. Pavement structural section design by a soils engineer shall be required on all private development projects. The design for structural sections shall be part of a Soils Report. The report shall be submitted in 8 ½ x 11 inch bound folder and include recommendations for: natural subgrade, geotextile fabric, subbase, base, and pavement compaction and thickness, and other requirements to achieve design strength.
- B. The minimum traffic index (T.I.) required for on-site pavement structural sections subjected mainly to vehicular traffic shall be 4.0. The minimum traffic index (T.I.) required for on-site pavement structural sections subjected mainly to truck traffic shall be 6.0. However, it is recommended that the developer/owner of the project design and construct a pavement structural section that provides maximum strength and durability for the projects' anticipated traffic loads.
- C. The minimum cross-slope of all pavement shall be one percent (1%).
- D. The Soils Engineer shall be on-site to monitor parking lot grading and to certify compaction and thickness of all components of the pavement structural section.
- E. Written certification of pavement grade by a registered civil engineer or licensed land surveyor and written certification of the structural section and compaction by a geotechnical engineer shall be required prior to the issuance of a Certificate of Occupancy. A Certificate of Occupancy will not be issued for any building if the pavement structural section or compaction does not conform to the requirements specified in the Soils Report.

NOTE: Pavement and Structural Section requirements shall not apply to single-family homes and duplexes.

2.02 STORM DRAINAGE DESIGN REQUIREMENTS

- A. Storm drain run-off from surfaces on-site and outside the City rights-of-way shall be routed to the City underground storm drain system via on-site catch basins and an underground system. It shall travel through a storm water filtering unit before reaching the City system. No surface run-off shall be routed to an adjoining private property unless approved by the City and authorized by a reciprocal drainage and maintenance easement or agreement. The pavement at the driveway entrance(s) to the project may be constructed so as to allow storm drainage to cross the driveway apron provided that the high point of the pavement is situated a maximum distance of thirty (30) feet measured from the back of driveway apron or sidewalk. The project engineer is encouraged to apply Low Impact Development (LID) principles to storm drain design.

- B. Roof drains shall not be discharged through the public street curb but shall be dissipated in the landscape area close to the building or connected directly to the on-site underground storm drain system.
- C. The finished floor elevation of all habitable areas of commercial, industrial, and multi-family residential structures shall be at least twelve (12) inches above the 100-year frequency storm hydraulic grade line elevation as determined by a storm drainage analysis. If such analysis is waived by the City Engineer, the finished floor elevation shall be a minimum of twelve (12) inches above the highest top of street curb elevation along the frontage of the site. In the absence of street curbs, the elevation of the crown of street shall be used.
- D. The design of all underground storm drain systems including their appurtenances within the building site property and up to within five (5) feet of the building shall conform to Division I, Section 4 of the City of Rio Vista Standard Specifications except for the following additions and modifications:
 - 1. Section 4.03B; Design Criteria: (4). The minimum inside diameter of on-site storm drainage pipe shall be eight (8) inches.
 - 2. Section 4.05A; Cover Requirements: Pipe depths, other than RCP, to finish grade and/or subgrade shall be in conformance with the specifications of the pipe manufacturer.
 - 3. Section 4.07A; Manholes: (2). All on-site storm drain manholes shall be constructed in accordance with the Standard Details. There are no City requirements for the spacing of on-site storm drain manholes. However, future maintenance and accessibility should be considered during design of the system.
 - 4. Section 4.07B; Junction boxes: Junction boxes for on-site drainage shall be reinforced concrete.
 - 5. Section 4.07.D; Catch Basins/Inlets: Drain inlets for on-site storm drainage shall be 12 inches in the least dimension. The maximum area draining into one inlet shall be one (1) acre. All inlets for on-site use that are not included in the Standard Details shall be clearly shown and dimensioned on the plans. All grates shall be designed to provide adequate safety for automobile traffic, bicycles and pedestrians.
 - 6. Section 4.07F; Valley Gutters: Valley gutters may be used for on-site drainage provided that a minimum slope of 0.003 feet per foot is maintained.

7. Pipe Materials and Use Conditions: Pipe materials and construction procedures for on-site storm drainage shall conform to these specifications unless otherwise approved by the City Engineer.
8. On-site underground storm drainage systems may be shown in plain view only, unless otherwise requested by the City Engineer.
9. The hydraulic grade line elevations for the design storm shall be shown on the site improvements plans at all locations of on-site drain inlets, catch basins and manholes wherever the hydraulic grade lines are above the top of the pipe.
10. The Consulting Engineer shall be responsible for designing a grading plan, which insures that storm waters flow through a development in a manner that will not flood habitable structures in the event of malfunction or overloading of the drainage system.
11. All Storm Drainage calculations shall be signed and stamped by a California registered civil engineer prior to approval by the City.

2.03 SANITARY SEWER DESIGN REQUIREMENTS

- A. The design of all underground sanitary sewer systems including their appurtenances within the building site property and up to within five (5) feet of the building shall conform to Division I, Section 5 of the City of Rio Vista Standard Specifications except for the following modifications and additions:
 1. Section 5.02A; Pipe Diameter: the minimum size of any on-site sanitary sewer main shall be four (4) inches in diameter.
 2. Section 5.03D; Pipe Cover and Clearances: Pipe depths to finish grade and/or subgrade must be in conformance with the specifications of the pipe manufacturer.
 3. Section 5.03I; Appurtenances: All on-site sanitary sewer manholes shall be constructed in accordance with the Standard Details. There are no City requirements for the spacing of on-site sanitary sewer manholes. However, future maintenance and accessibility should be considered.
 4. Pipe material and construction procedure for on-site sanitary sewer systems shall conform to these specifications unless otherwise approved by the City Engineer.
 5. All Sanitary Sewer Design Calculations shall be signed and stamped by a California registered civil engineer prior to approval by the City.

6. Facilities with the potential to generate fats, oils or grease will be required to install an interceptor prior to connection to City system. Said interceptor shall be approved by the City.

2.04 WATER SYSTEM DESIGN REQUIREMENTS

- A. The design of all underground water systems including their appurtenances within the building site property and up to within five (5) feet of the building shall conform to Division I, Section 6 of the City of Rio Vista Standard Specifications except for the following modifications and additions:
 1. Section 6.02C; Sizes: There are no City requirements for minimum size of on-site water mains. Water mains shall be sized to meet domestic, fire sprinkler and fire flow requirements.
 2. Section 6.02E; Pipe Materials: Pipe materials and construction procedures for on-site water mains shall conform to these specifications unless otherwise approved by the City Engineer.
 3. Section 6.02L; Cover Requirements: Minimum cover over private fire mains shall not be less than 36” inches beneath paved sections subject to vehicle traffic loads and not less than 48” inches under railroad tracks as measured from the top of pipe to finish grade.
 4. On-site fire lines: The Engineering Division will plan check and inspect the portion of the underground fire line from the tap at the City main up through and including the last ell at the downstream end of the backflow device.
 5. Backflow Certifications: All backflow devices inspected by the City Engineer shall be tested and approved by a certified tester prior to any permit final or Certificate of Occupancy.
 6. On-site fire hydrants: On-site fire hydrants shall be jointly inspected and approved by the City Engineer and the Building Inspection Department prior to any permit final or Certificate of Occupancy. On-site hydrants shall conform to these Design Standards, and Standard Detail.

STANDARD PLANS

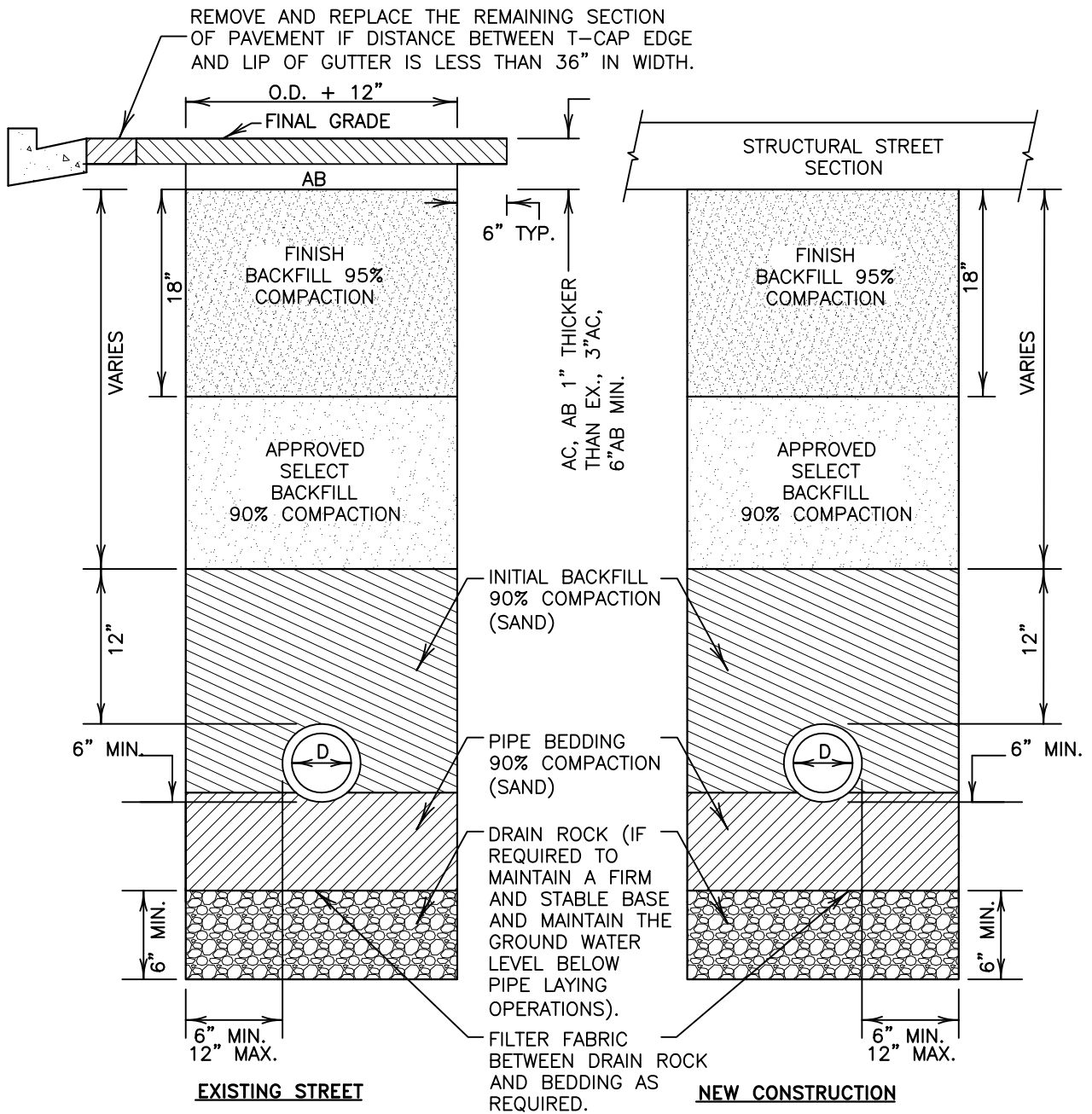

NOTES:

- A. IN EXISTING STREETS, A TEMPORARY LAYER (3" MINIMUM) OF ASPHALT CUT BACK SHALL BE PLACED TO GRADE ON TOP OF THE FINISH BACKFILL AND MAINTAINED UNTIL PERMANENT PAVING IS INSTALLED.
- B. PONDING OR JETTING PERMITTED TO THE TOP OF PIPE IF APPROVED BY SOILS ENGINEER.
- C. ALL EXISTING PAVEMENT SHALL BE NEATLY CUT TO LINE PRIOR TO TRENCH EXCAVATION.
- D. INITIAL BACKFILL SHALL BE MECHANICALLY CONSOLIDATED UNDER HAUNCHES OF THE PIPE.
- E. PIPE BEDDING SHALL BE A MINIMUM OF 6 INCHES
- F. THE MAXIMUM LENGTH OF OPEN TRENCH SHALL BE THE DISTANCE NECESSARY TO ACCOMODATE THE AMOUNT OF PIPE WHICH CAN BE INSTALLED IN A SINGLE DAY.
- G. PLACEMENT OF SPOIL MATERIALS ON THE PAVED STREET WILL NOT BE ALLOWED.
- H. STEEL PLATES WILL BE ALLOWED TO COVER AN OPEN TRENCH UP TO A MAXIMUM LENGTH OF 50 FEET. PLATES SHALL BE SECURED AS NECESSARY AND HAVE COLD MIX PLACED AROUND ALL EDGES. NON-SKID PLATES ARE REQUIRED IN ALL PAVED AREAS.
- I. ALTERNATE BACKFILL MATERIAL AND METHODS SHALL BE SUBJECT TO APPROVAL BY THE CITY ENGINEER.

NO.	REVISION	DATE	BY
DRAWN BY: BH, NR			
CHECKED BY: CD			
SCALE: NONE			
DATE: 03/2015			

TRENCH BACKFILL

CITY OF RIO VISTA
DEPARTMENT OF PUBLIC WORKS

APPROVED BY: **CECIL DILLON** DECEMBER 2015
CITY ENGINEER
RCF 25835

DATE

STANDARD PLAN NO. 101

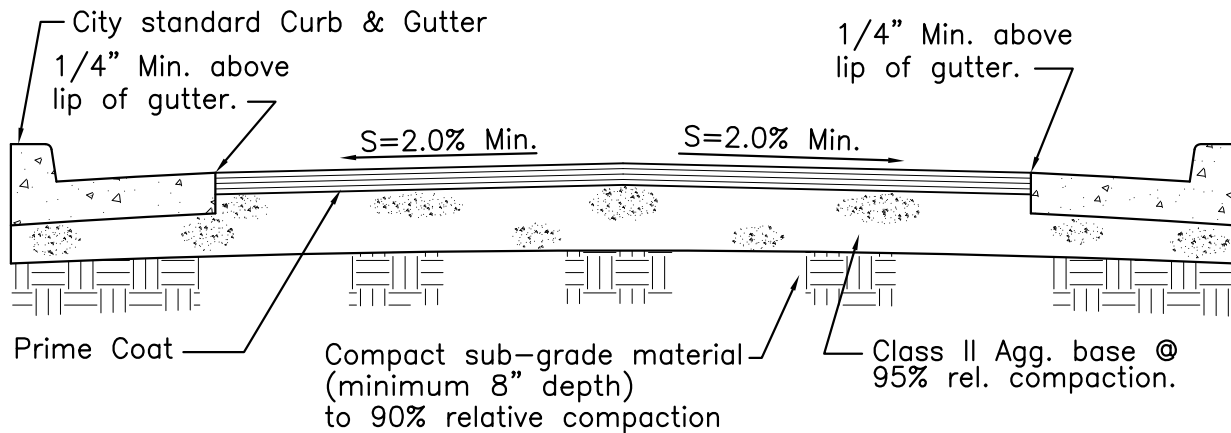

- NOTE:**
1. TRAFFIC INDEXED (T.I.) SHOWN ON STREET SECTIONS ARE MINIMUMS. ALL STRUCTURAL SECTIONS SHALL BE BASED ON A 20 YEAR DESIGN LIFE AS DETERMINED BY EXISTING R-VALUE AND T.I. WHICH SHALL INCLUDE ANTICIPATED TRAFFIC AS WELL AS EXISTING TRAFFIC CONDITIONS. STRUCTURAL SECTIONS ARE PER A QUALIFIED SOILS ENGINEER'S REPORT AND SUBJECT TO THE CITY ENGINEERS APPROVAL.
 2. WHERE EXISTING FACILITIES MUST MATCH THE CROSS SLOPE MAY VARY BETWEEN 2% AND 4%.
 3. SEE DRAWINGS 202-216 FOR CURB AND GUTTER, SIDEWALK AND DRIVEWAYS.

NO.	REVISION	DATE	BY
DRAWN BY: BH, NR			
CHECKED BY: CD			
SCALE: NONE			
DATE: 03/2015			

TYPICAL STREET SECTION REQUIREMENTS

CITY OF RIO VISTA
DEPARTMENT OF PUBLIC WORKS

APPROVED BY:	DECEMBER
CECIL DILLON	2015
CITY ENGINEER	DATE
RCE 25835	

STANDARD
PLAN NO. **201**

P.U.E. = Public Utility Easement

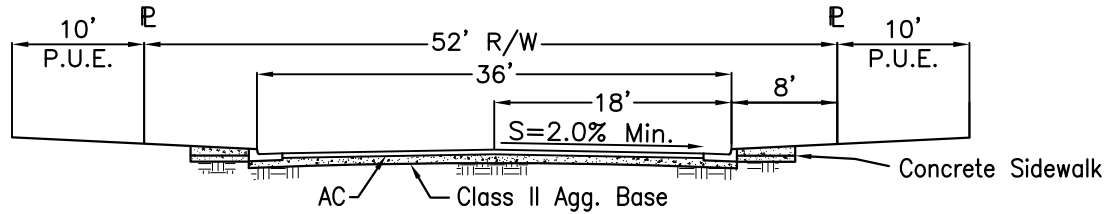

Minor/Local

T.I. = 6.5 Minimum
Design Speed = 25 M.P.H.

P.U.E. = Public Utility Easement

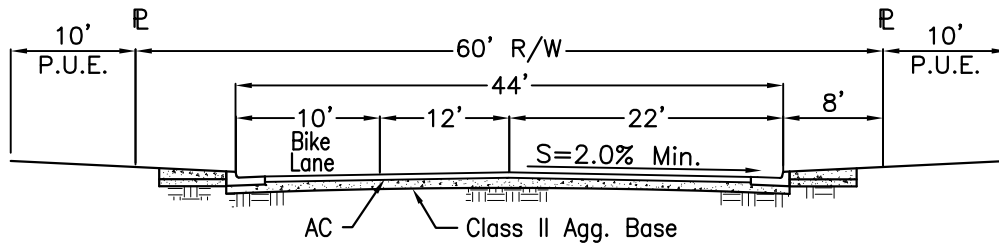

Collector

T.I. = 6.5 Minimum
Design Speed = 35 M.P.H.

P.U.E. = Public Utility Easement

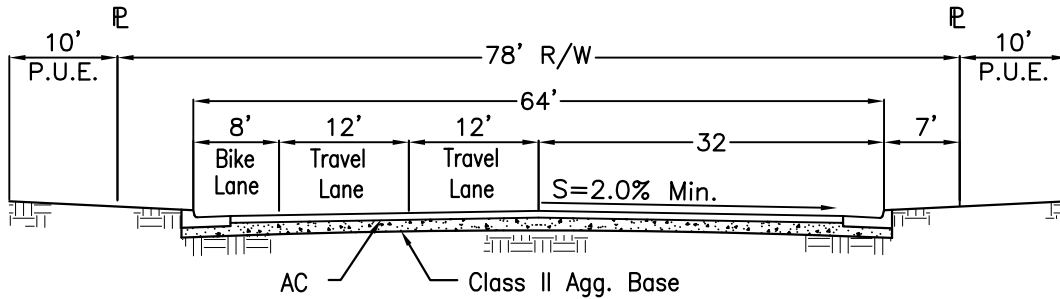

Major/Industrial

T.I. = 8.0 Minimum
Design Speed = 35 M.P.H.

NO.	REVISION	DATE	BY
DRAWN BY: BH, NR			
CHECKED BY: CD			
SCALE: NONE			
DATE: 03/2015			

STREET SECTION

CITY OF RIO VISTA
DEPARTMENT OF PUBLIC WORKS

APPROVED BY: **CECIL DILLON** DECEMBER 2015
CITY ENGINEER
RCF 25835

DATE

STANDARD PLAN NO. **202**

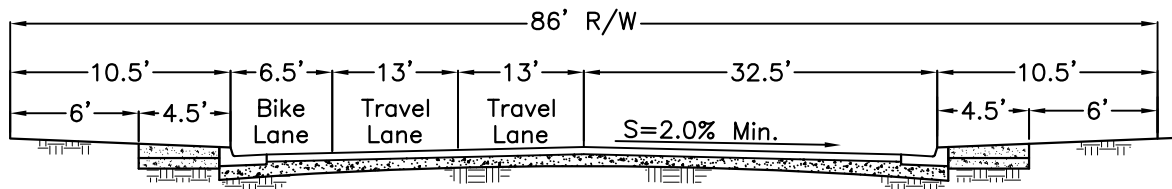

T.I. = 8.0 Minimum
 Design Speed = 45 M.P.H.
 No Parking

4-Lane Undivided Arterial

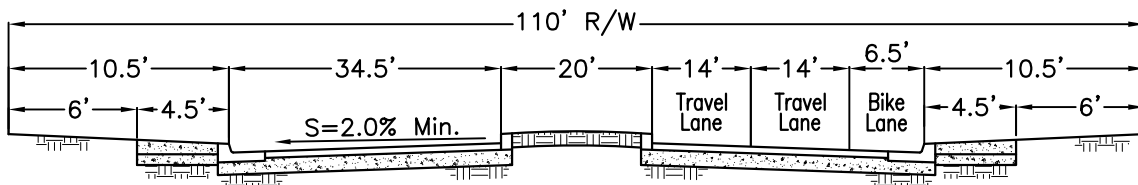

T.I. = 8.0 Minimum
 Design Speed = 45 M.P.H.
 No Parking

4-Lane Divided Arterial

NO.	REVISION	DATE	BY
DRAWN BY: BH, NR			
CHECKED BY: CD			
SCALE: NONE			
DATE: 03/2015			

STREET SECTION

CITY OF RIO VISTA
 DEPARTMENT OF PUBLIC WORKS

APPROVED BY: **CECIL DILLON** DECEMBER 2015
 CITY ENGINEER DATE
 RCF 25835

STANDARD PLAN NO. 203

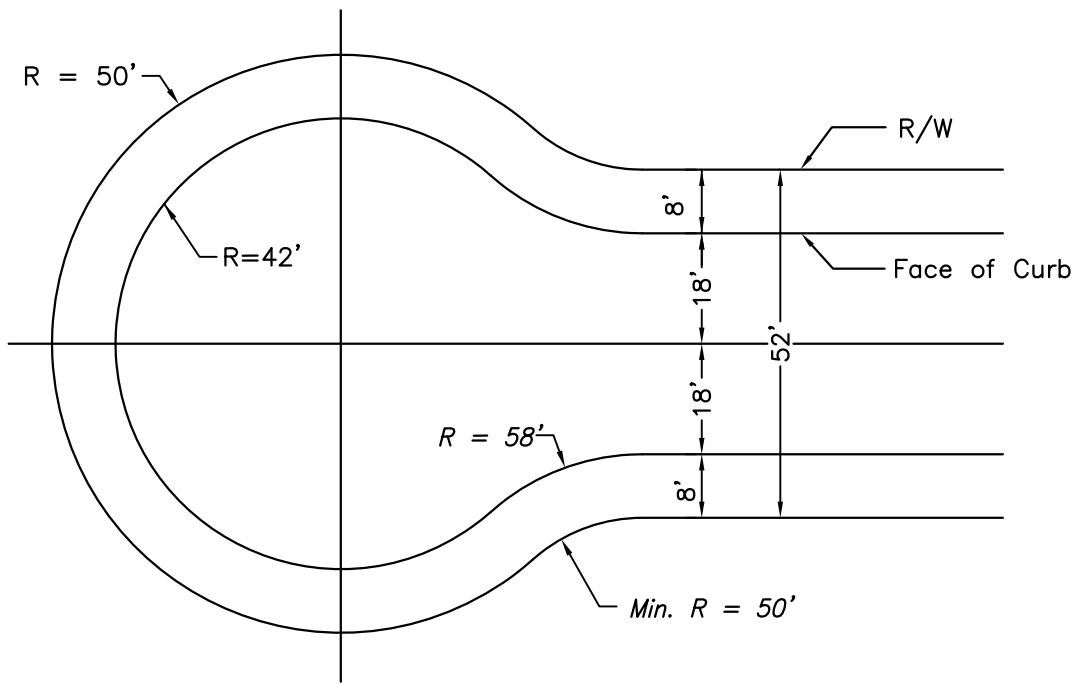

Minor/Local Cul-De-Sac

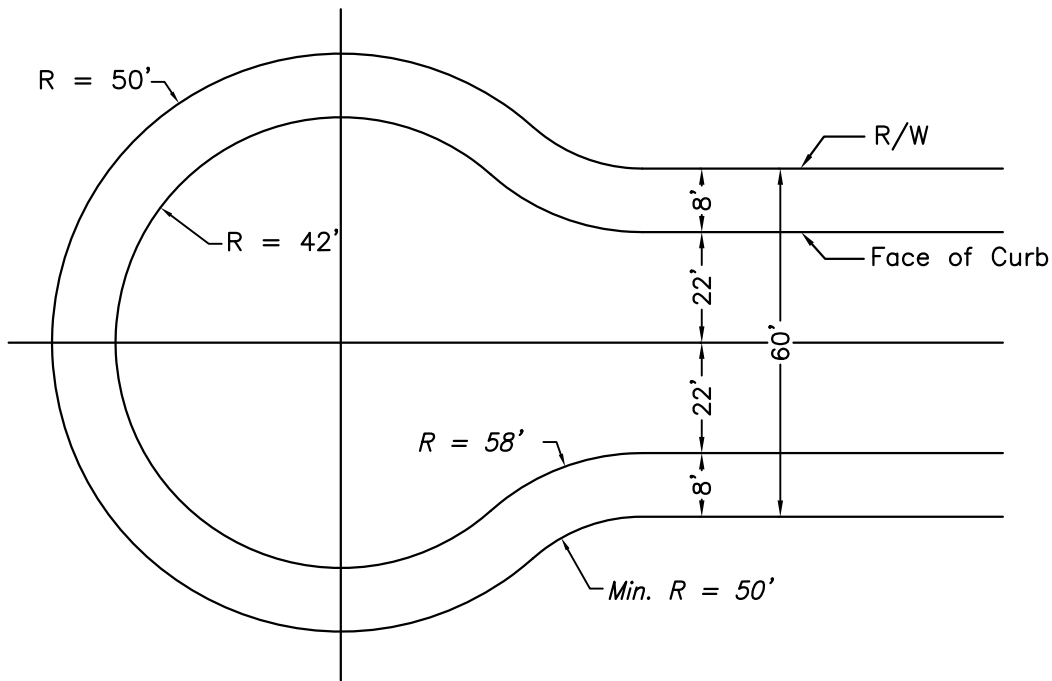

Collector Cul-De-Sac

NO.	REVISION	DATE	BY
DRAWN BY: BH, NR			
CHECKED BY: CD			
SCALE: NONE			
DATE: 03/2015			

CUL-DE-SAC TURN AROUND

CITY OF RIO VISTA
DEPARTMENT OF PUBLIC WORKS

APPROVED BY: CECIL DILLON
CITY ENGINEER
RCE 25835
DECEMBER 2015
DATE

STANDARD PLAN NO. **204**

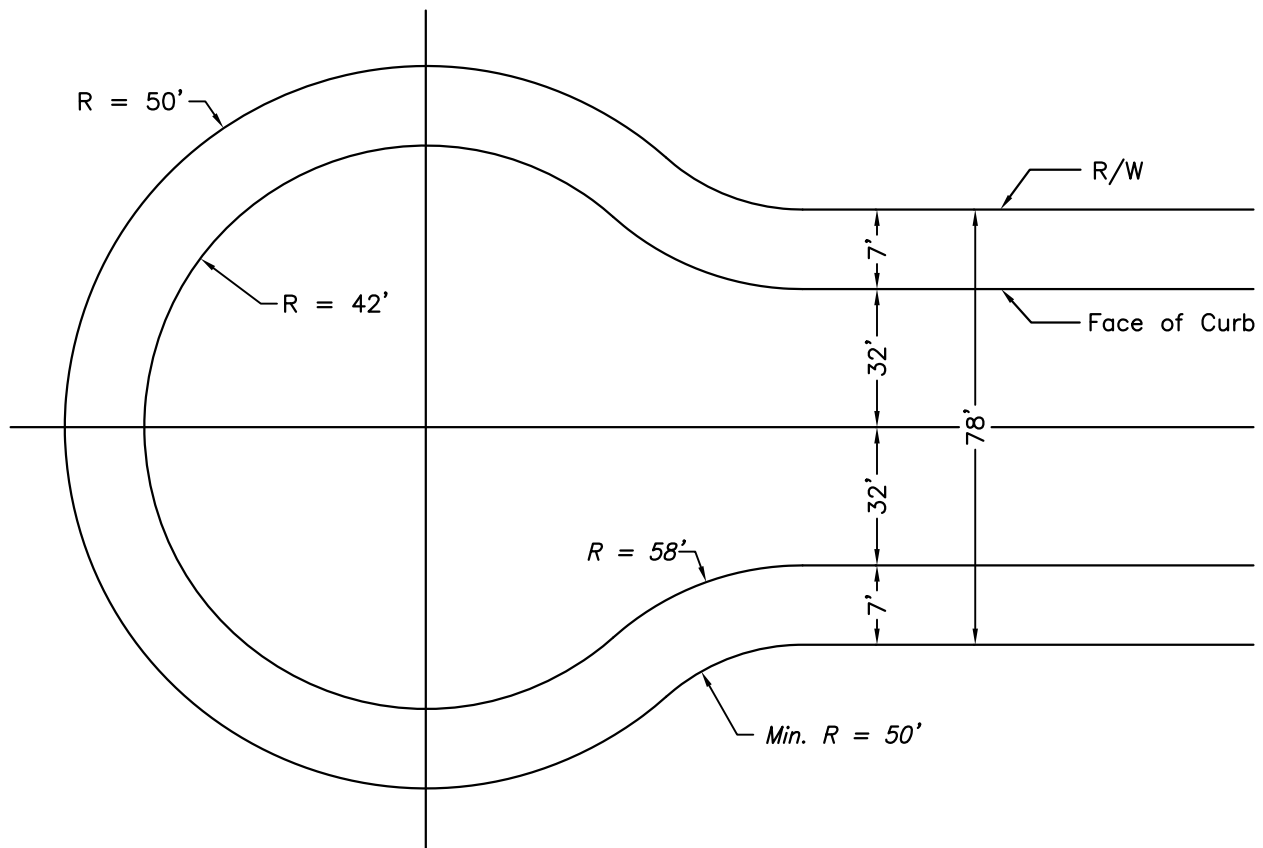

Industrial Cul-De-Sac

NO.	REVISION	DATE	BY
DRAWN BY: BH, NR			
CHECKED BY: CD			
SCALE: NONE			
DATE: 03/2015			

CUL-DE-SAC TURN AROUND

CITY OF RIO VISTA
DEPARTMENT OF PUBLIC WORKS

APPROVED BY: **CECIL DILLON** DECEMBER 2015
CITY ENGINEER DATE
RCE 25835

STANDARD PLAN NO. **205**

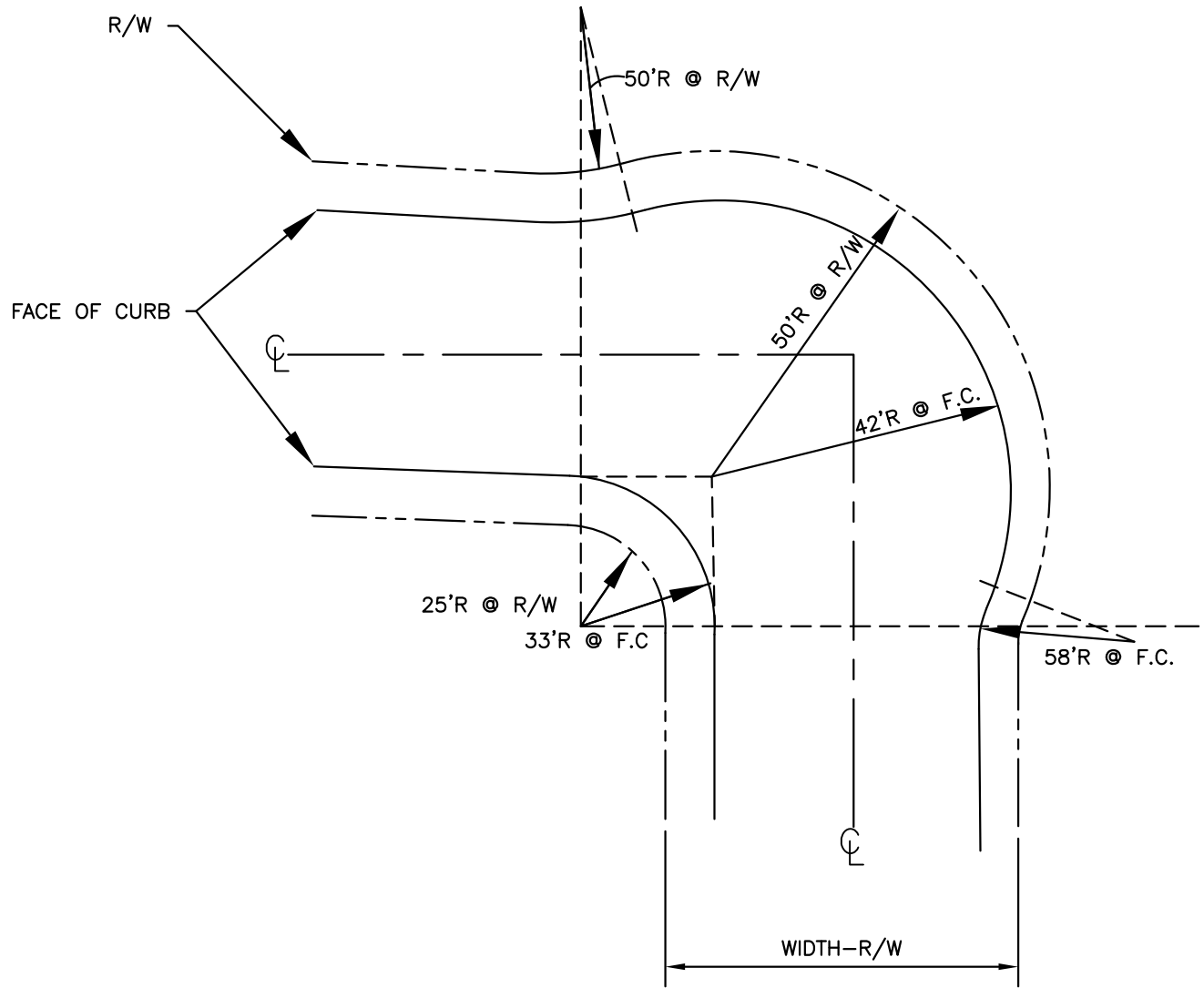

STANDARD EXPANDED CORNER

NO.	REVISION	DATE	BY
DRAWN BY: BH, NR			
CHECKED BY: CD			
SCALE: NONE			
DATE: 03/2015			

**MINOR & LOCAL ROADS
EXPANDED CORNER**

CITY OF RIO VISTA
DEPARTMENT OF PUBLIC WORKS

APPROVED BY: **CECIL DILLON** DECEMBER 2015
 CITY ENGINEER DATE
 RCE 25835

STANDARD PLAN NO. **206**

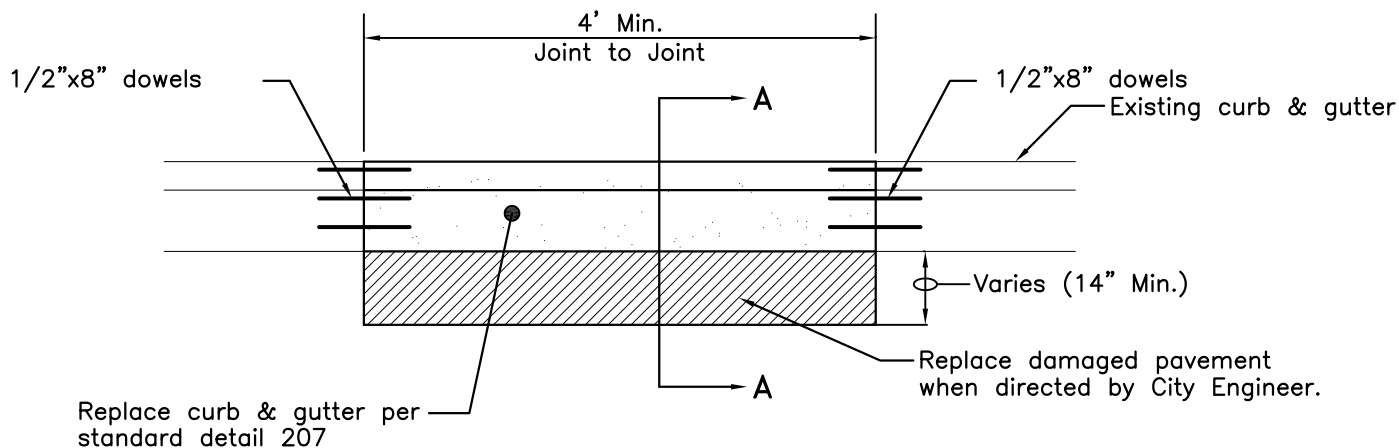

PLAN:

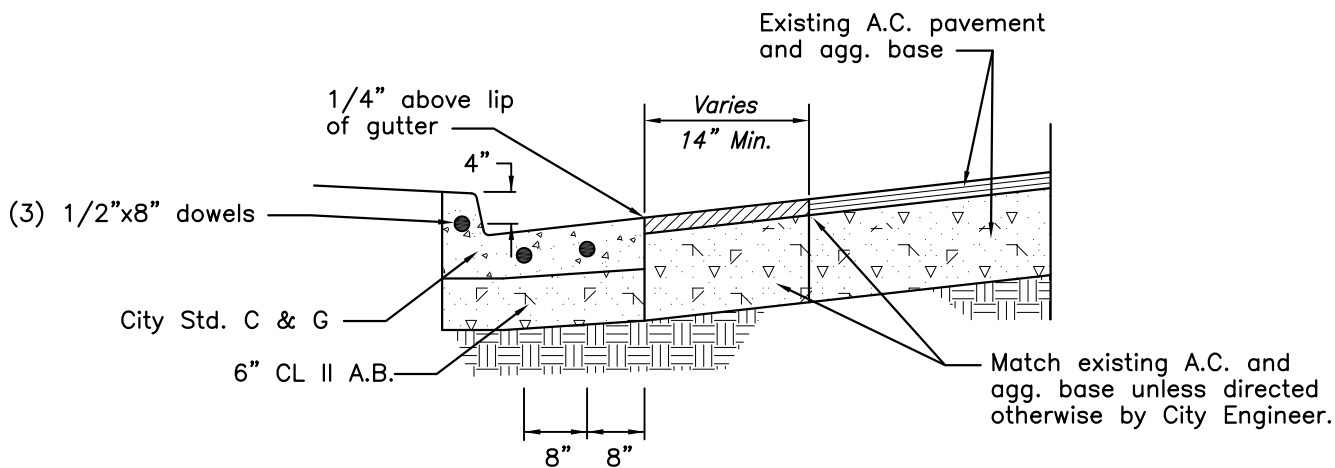

SECTION A-A

NO.	REVISION	DATE	BY
DRAWN BY: BH, NR			
CHECKED BY: CD			
SCALE: NONE			
DATE: 03/2015			

**CURB AND GUTTER REPLACEMENT
IN EXISTING STREETS**

CITY OF RIO VISTA
DEPARTMENT OF PUBLIC WORKS

APPROVED BY:	DECEMBER
CECIL DILLON	2015
CITY ENGINEER	DATE
RCE 25835	

**STANDARD
PLAN NO. 208**

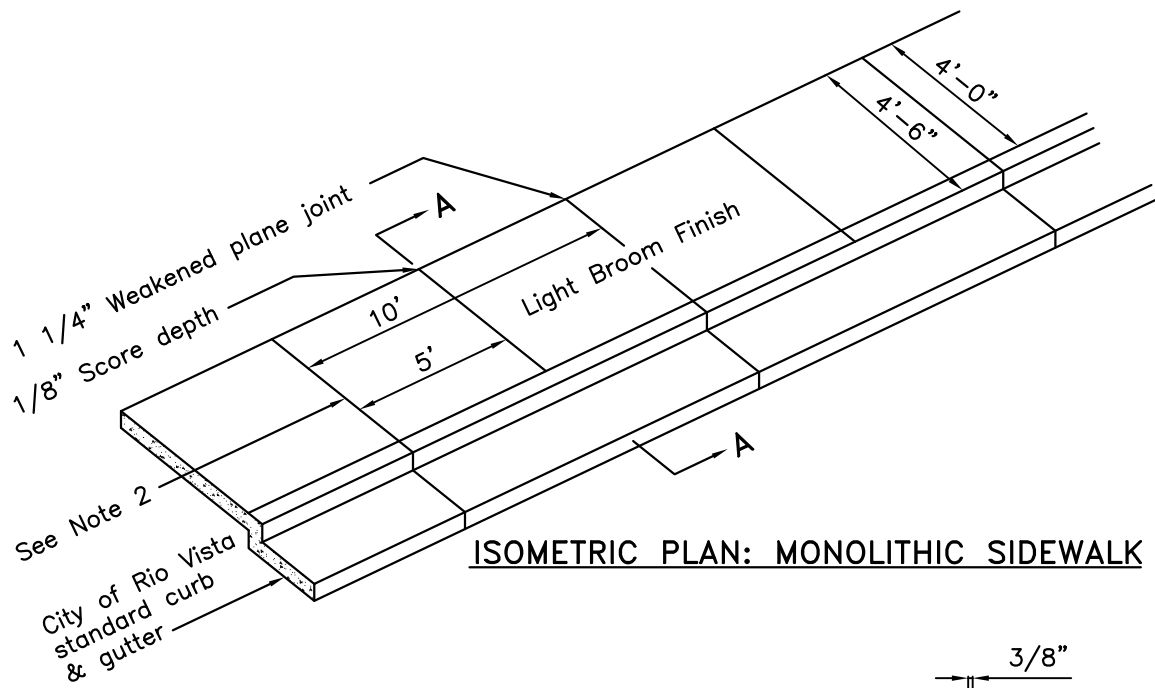

ISOMETRIC PLAN: MONOLITHIC SIDEWALK

NOTES:

1. EXPANSION JOINTS SHALL BE PLACED AS FOLLOWS:
 - A. ON EACH SIDE OF DRIVEWAY
 - B. AT A MAXIMUM DISTANCE OF 60 FEET
2. A 1 1/4" WEAKENED PLANE JOINT SHALL BE PLACED EVERY 10' AND A 1/8" SCORE LINE EVERY 5'

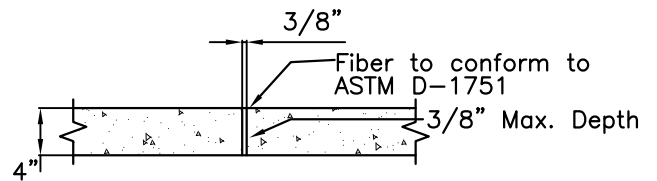

DETAIL: EXPANSION JOINT

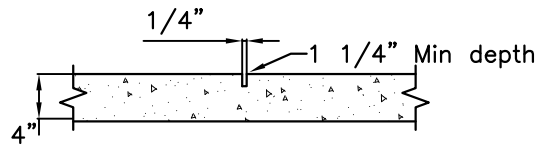

DETAIL: WEAKENED PLANE JOINT

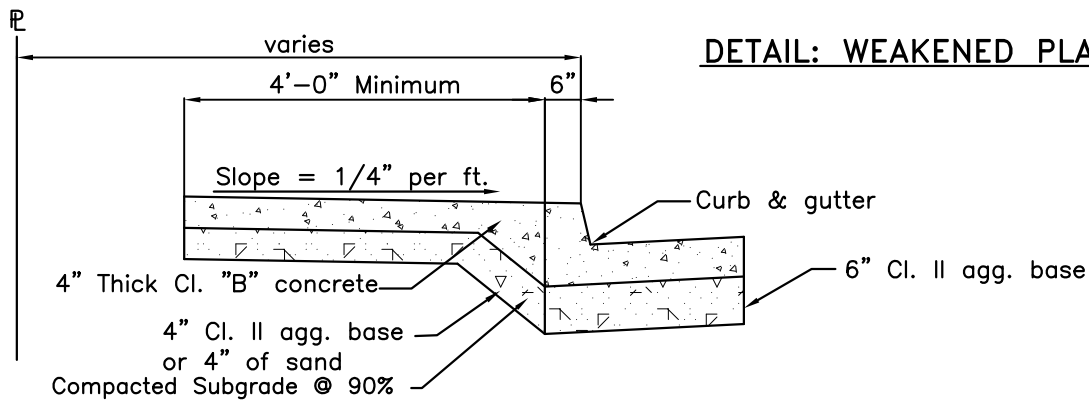

SECTION A-A

NO.	REVISION	DATE	BY
DRAWN BY: BH, NR			
CHECKED BY: CD			
SCALE: NONE			
DATE: 03/2015			

MONOLITHIC SIDEWALK

CITY OF RIO VISTA
DEPARTMENT OF PUBLIC WORKS

APPROVED BY: **CECIL DILLON** DECEMBER 2015
CITY ENGINEER
RCE 25835 DATE

STANDARD PLAN NO. **209**

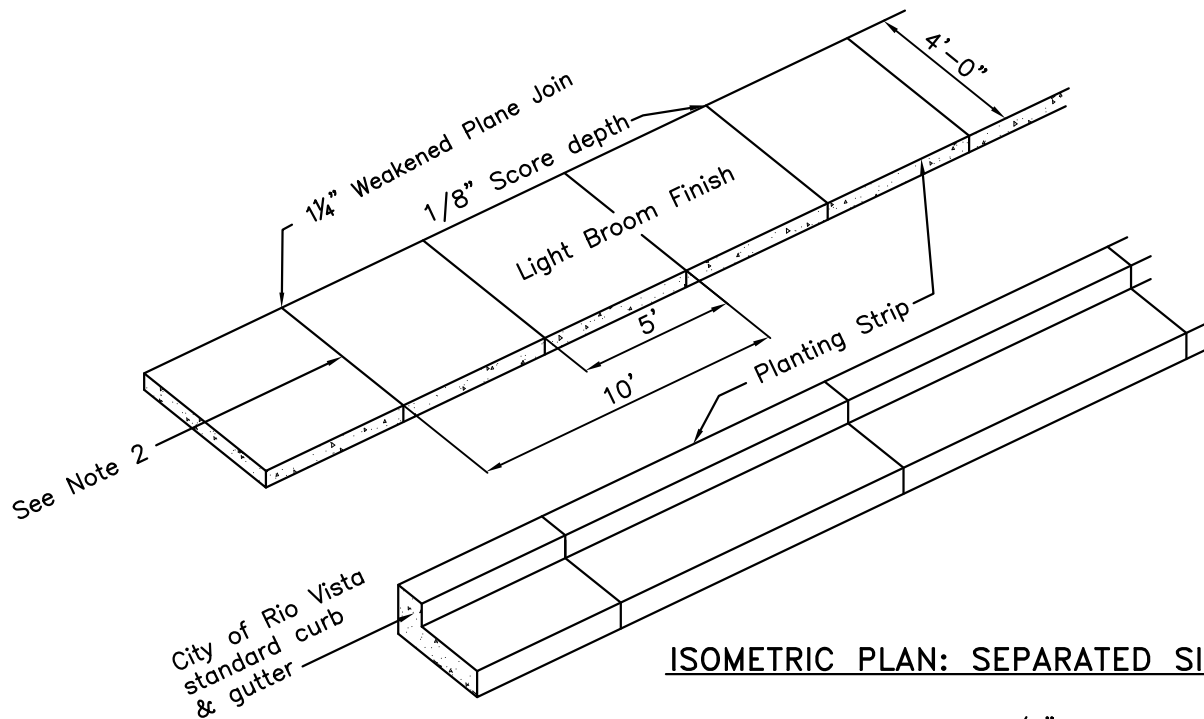

ISOMETRIC PLAN: SEPARATED SIDEWALK

NOTES:

1. EXPNSION JOINTS SHALL BE PLACED AS FOLLOWS:
 - A. ON EACH SIDE OF DRIVEWAY
 - B. AT A MAXIMUM DISTANCE OF 60 FEET
2. A 1/4" WEAKENED PLANE JOINT SHALL BE PLACED EVERY 10' AND A 1/8" SCORE LINE EVERY 5'

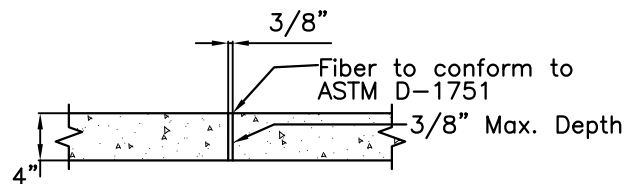

DETAIL: EXPANSION JOINT

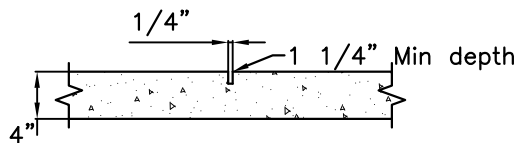

DETAIL: WEAKENED PLANE JOINT

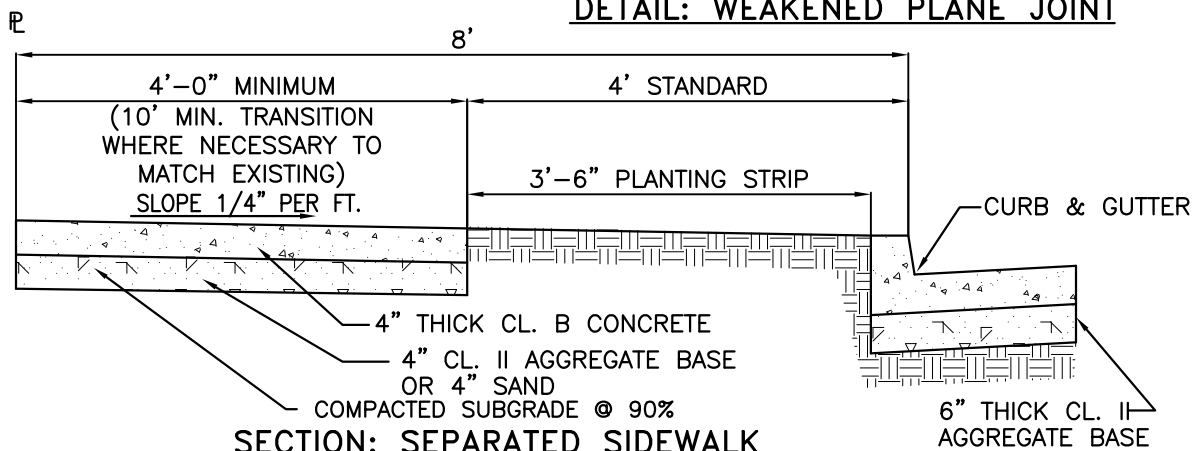

SECTION: SEPARATED SIDEWALK

NO.	REVISION	DATE	BY

DRAWN BY: BH, NR
 CHECKED BY: CD
 SCALE: NONE
 DATE: 03/2015

SEPARATED SIDEWALK

CITY OF RIO VISTA
 DEPARTMENT OF PUBLIC WORKS

APPROVED BY: **CECIL DILLON** DECEMBER 2015
 CITY ENGINEER
 RCF 25835 DATE

STANDARD PLAN NO. 210

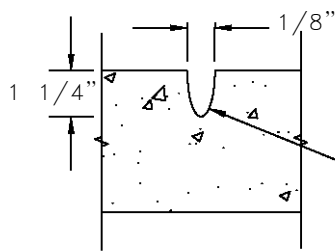
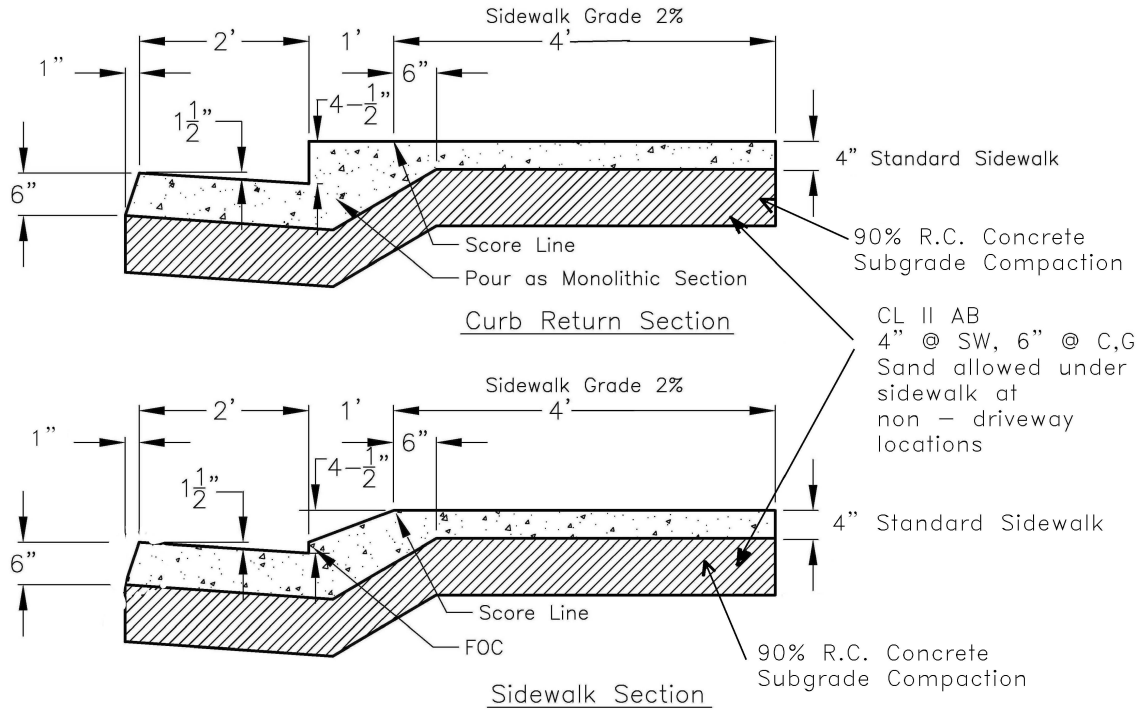

Detail
Weakened Plane Joint

If joint is greater than 1/4" wide it shall be filled with petrolastic material.

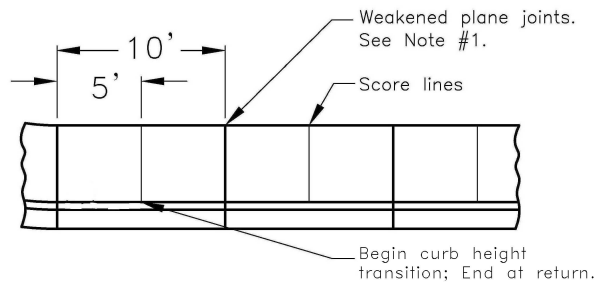

Plan - transition from rolled curb to vertical curb

NOTES:

1. CONSTRUCT WEAKENED PLANE JOINTS AT 10'.
2. USE IMPERVIOUS MEMBRANE CURE. BROOM FINISH
3. CLASS B CONCRETE PER SECTION 90 OF STATE STANDARD SPECIFICATIONS, 1-1/2" MAX. AGGREGATE.
4. CONSTRUCT EXPANSION JOINTS AT 60' MAX. AND AT BCR AND ECR.
5. ALL EXPOSED EDGES SHALL BE ROUNDED TO 1" RADIUS.

NO.	REVISION	DATE	BY
DRAWN BY: BH, NR			
CHECKED BY: CD			
SCALE: NONE			
DATE: 03/2015			

**ROLLED CURB, GUTTER
& SIDEWALK**

CITY OF RIO VISTA
DEPARTMENT OF PUBLIC WORKS

APPROVED BY: **CECIL DILLON** DECEMBER 2015
CITY ENGINEER
RCF 25835 DATE

STANDARD PLAN NO. 211

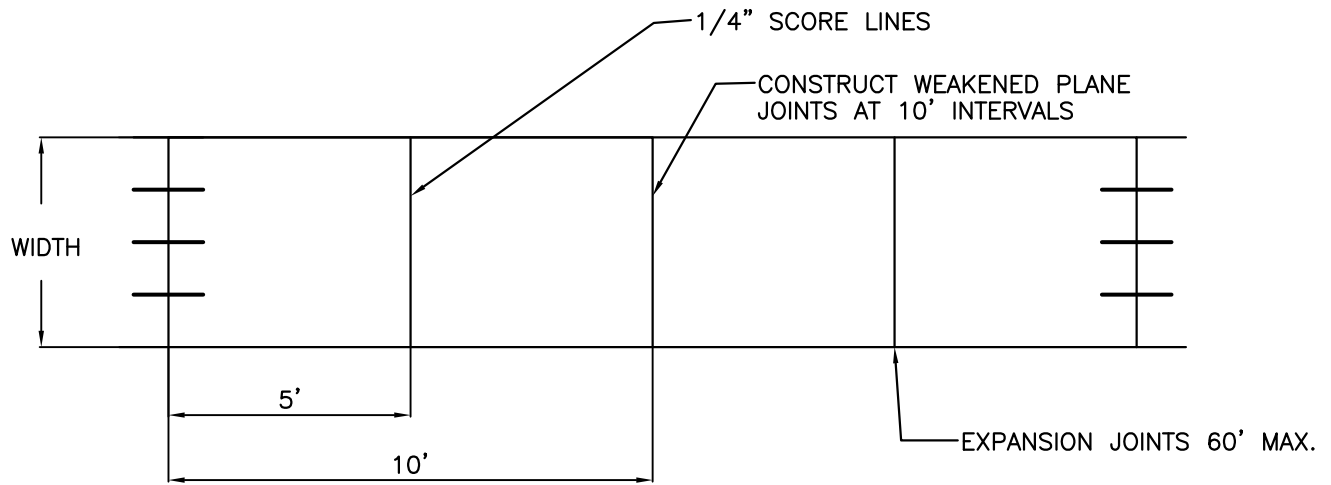

PLAN

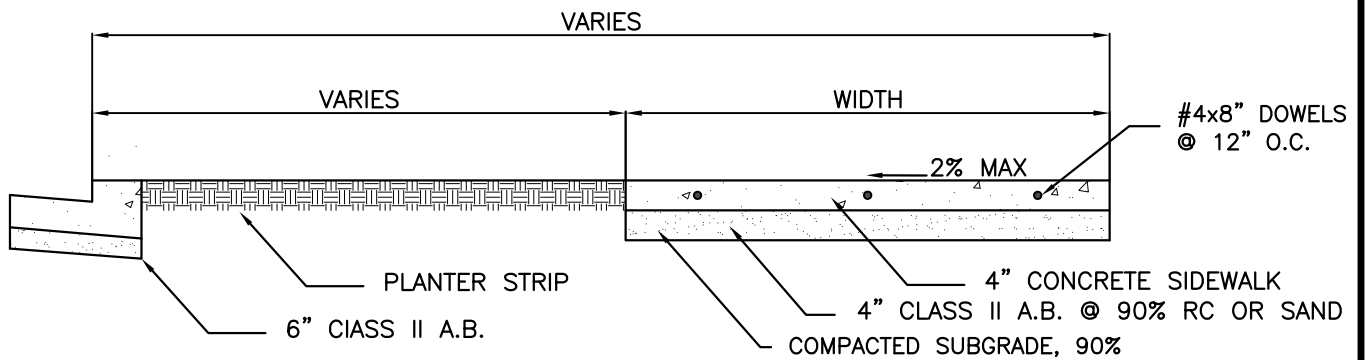

SIDEWALK DETAIL

IF JOINT IS GREATER THAN 1/4" WIDE IT SHALL BE FILLED WITH PETROLASTIC MATERIAL

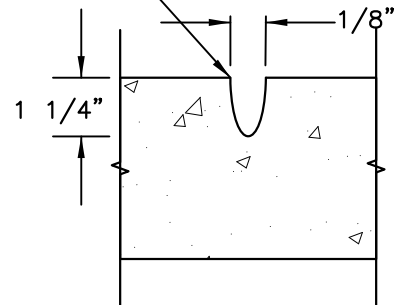

WEAKENED PLANE JOINT DETAIL

NOTES:

1. MATCH WIDTH WITH ADACENT EXISTING SIDEWALK. FOR REPLACEMENT LESS THAN 11' MATCH SCORING PATTERN.
2. CONCRETE SHALL BE 2500 PSI @ 28 DAYS. MAX 4" SLUMP. FOR JOBS LESS THAN ONE YARD, NO STATIC TRAILER MIX, MIXER TRAILER MAY BE USED.
3. ALL REAPIRS TO SIDEWALK OR CURB SHALL BE SAWCUT AT THE NEAREST SCORE LINES OR JOINT AND COMPLETELY REMOVED OR REPLACED.
4. LIGHT BROOM FINISH.
5. IMPERVIOUS MEMBRANE CURE.

NO.	REVISION	DATE	BY
DRAWN BY: BH, NR			
CHECKED BY: CD			
SCALE: NONE			
DATE: 03/2015			

SIDEWALK REPAIR

CITY OF RIO VISTA
DEPARTMENT OF PUBLIC WORKS

APPROVED BY: **CECIL DILLON** DECEMBER 2015
CITY ENGINEER
RCF 25835 DATE

STANDARD PLAN NO. **212**

NOTE:

WHEN GUTTER AND APPROACH ARE POURED SEPARATELY, USE ONE 8" LENGTH OF #4 bar each 24" of curb as doweling.

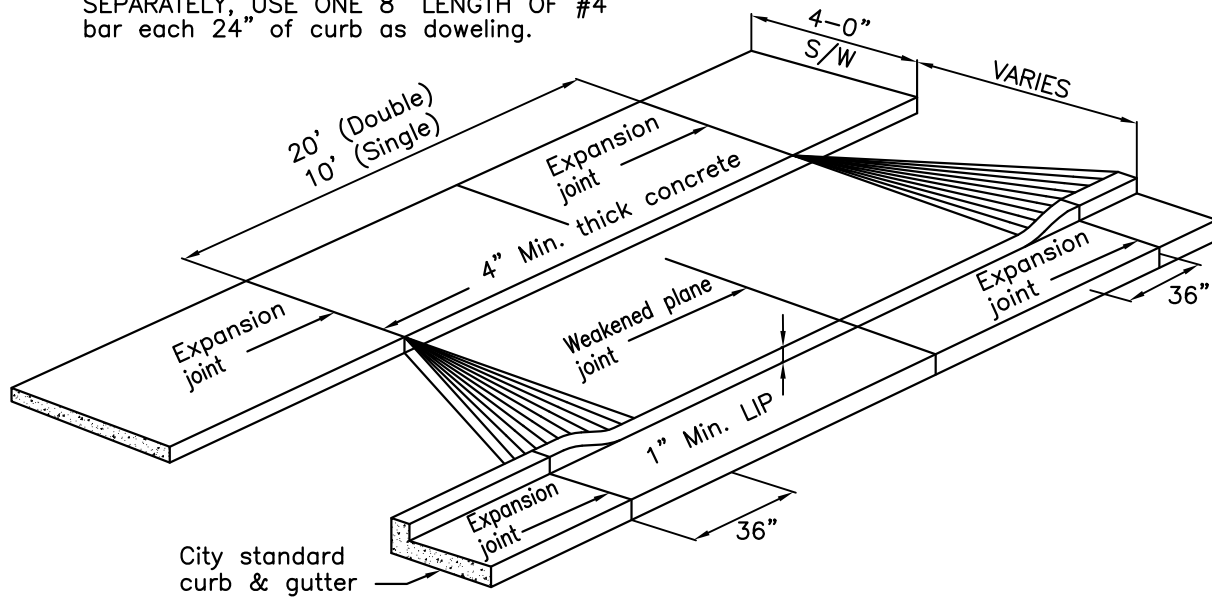

ISOMETRIC PLAN: DRIVEWAY APPROACH

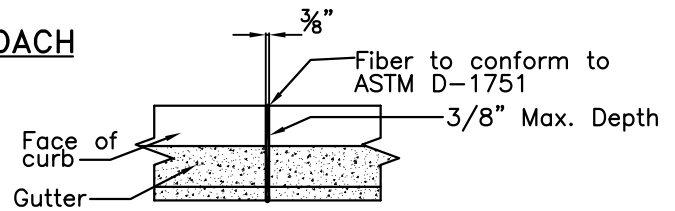

DETAIL: EXPANSION JOINT

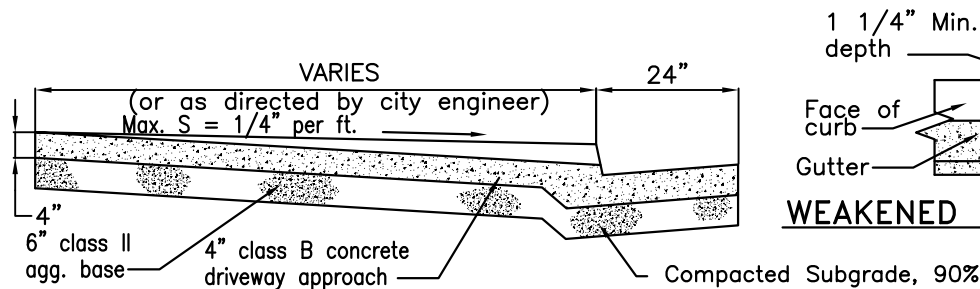

SECTION: DRIVEWAY APPROACH

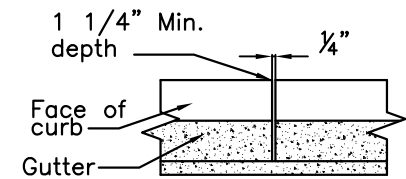

WEAKENED PLANE JOINT

NO.	REVISION	DATE	BY
DRAWN BY: BH, NR			
CHECKED BY: CD			
SCALE: NONE			
DATE: 03/2015			

RESIDENTIAL DRIVEWAY AT SEPARATED SIDEWALK

CITY OF RIO VISTA
DEPARTMENT OF PUBLIC WORKS

APPROVED BY: **CECIL DILLON** DECEMBER 2015
CITY ENGINEER RCF 25835 DATE

STANDARD PLAN NO. **213**

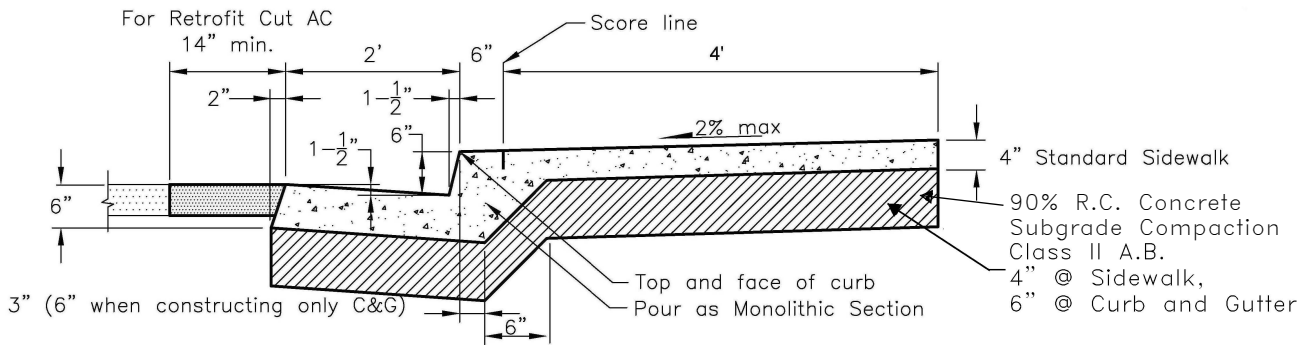

Class II A.B.
4" @ Sidewalk,
6" @ Curb &
Gutter

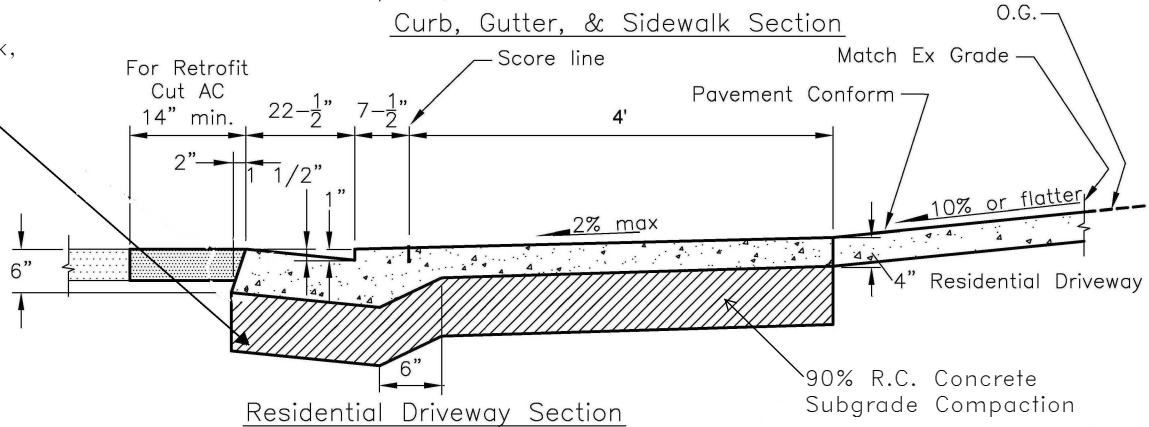

Bench Mark monuments will be furnished by the City of Rio Vista, when required, and shall be installed by the contractor as directed by the City Engineer.

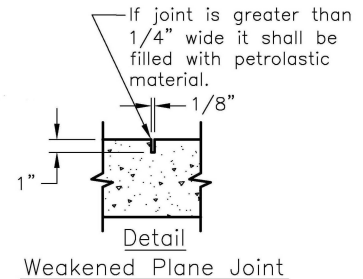
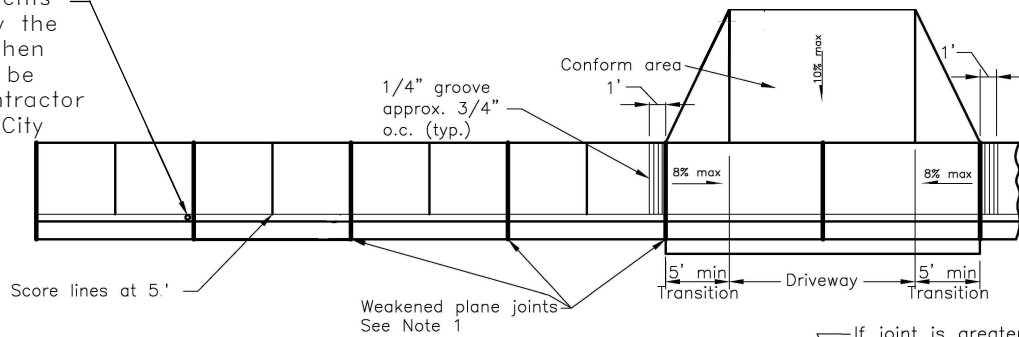

NOTES:

1. CONSTRUCT WEAKENED PLANE JOINTS AT 10', AND AT ENDS OF TRANSITION & CENTERLINE OF DRIVEWAY.
2. USE IMPERVIOUS MEMBRANE CURE. BROOM FINISH
3. CLASS "B" CONCRETE PER SECTION 90 OF STATE STANDARD SPECIFICATIONS, 1-1/2" MAX. AGGREGATE.
4. CONSTRUCT EXPANSION JOINTS AT 60' MAX.
5. ALL EXPOSED EDGES SHALL BE ROUNDED TO 1" RADIUS.
6. 4" SAND ALLOWED UNDER SIDEWALK AT NON-DRIVEWAY LOCATIONS.

NO.	REVISION	DATE	BY
DRAWN BY: BH, NR			
CHECKED BY: CD			
SCALE: NONE			
DATE: 03/2015			

**VERTICAL-TYPE CURB,
GUTTER, SIDEWALK AND
RESIDENTIAL DRIVEWAY**

**CITY OF RIO VISTA
DEPARTMENT OF PUBLIC WORKS**

APPROVED BY: **CECIL DILLON** DECEMBER 2015
CITY ENGINEER
RCF 25835

DATE

STANDARD PLAN NO. **214**

NOTES: 1. When driveway and gutter approach are poured separately, use one 8" length of #4 bar each 24" of curb as doweling.

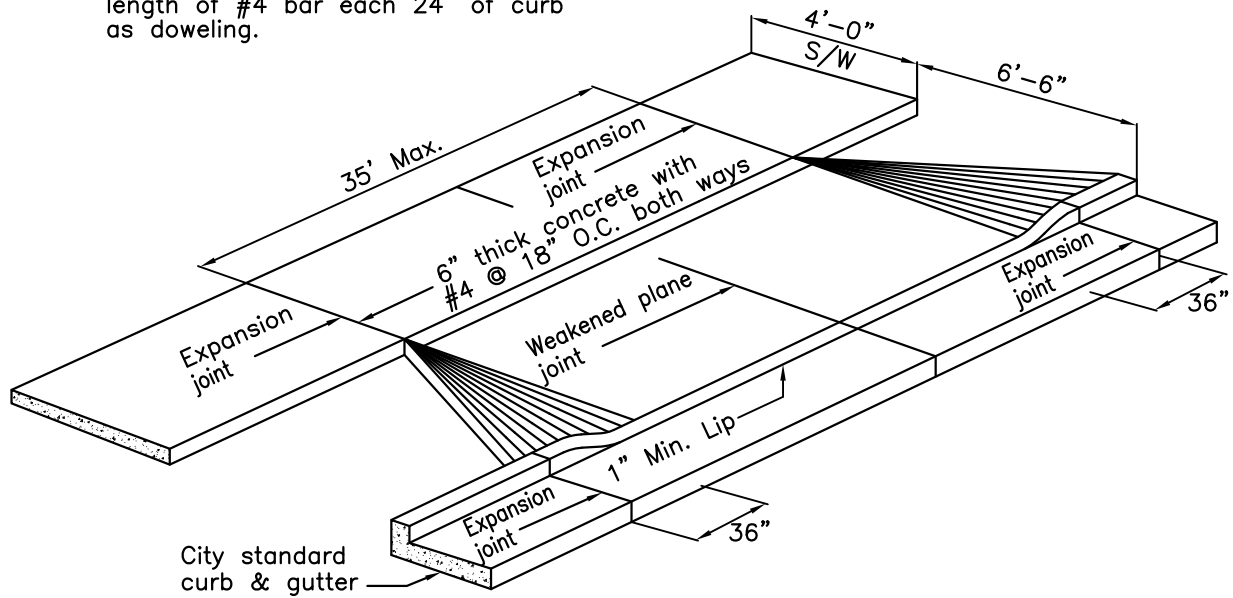

ISOMETRIC PLAN: DRIVEWAY APPROACH

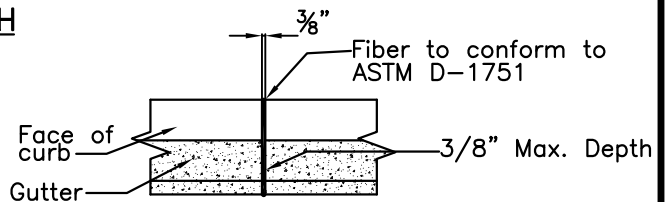

DETAIL: EXPANSION JOINT

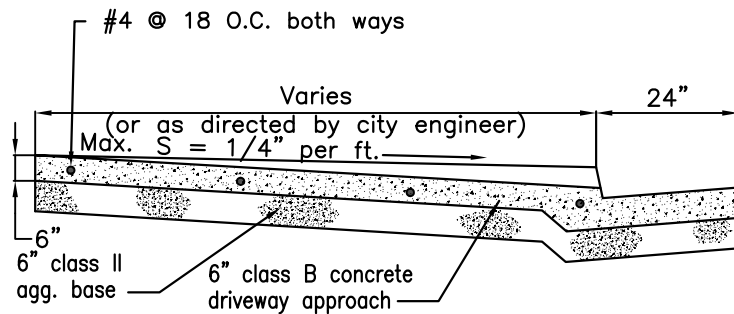

SECTION: DRIVEWAY APPROACH

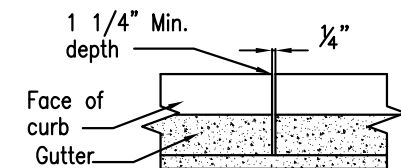

WEAKENED PLANE JOINT

NO.	REVISION	DATE	BY
DRAWN BY: BH, NR			
CHECKED BY: CD			
SCALE: NONE			
DATE: 03/2015			

**COMMERCIAL AND INDUSTRIAL
DRIVEWAY WITH SEPARATED SIDEWALK**

**CITY OF RIO VISTA
DEPARTMENT OF PUBLIC WORKS**

APPROVED BY: **CECIL DILLON** DECEMBER 2015
CITY ENGINEER RCF 25835 DATE

STANDARD PLAN NO. 215

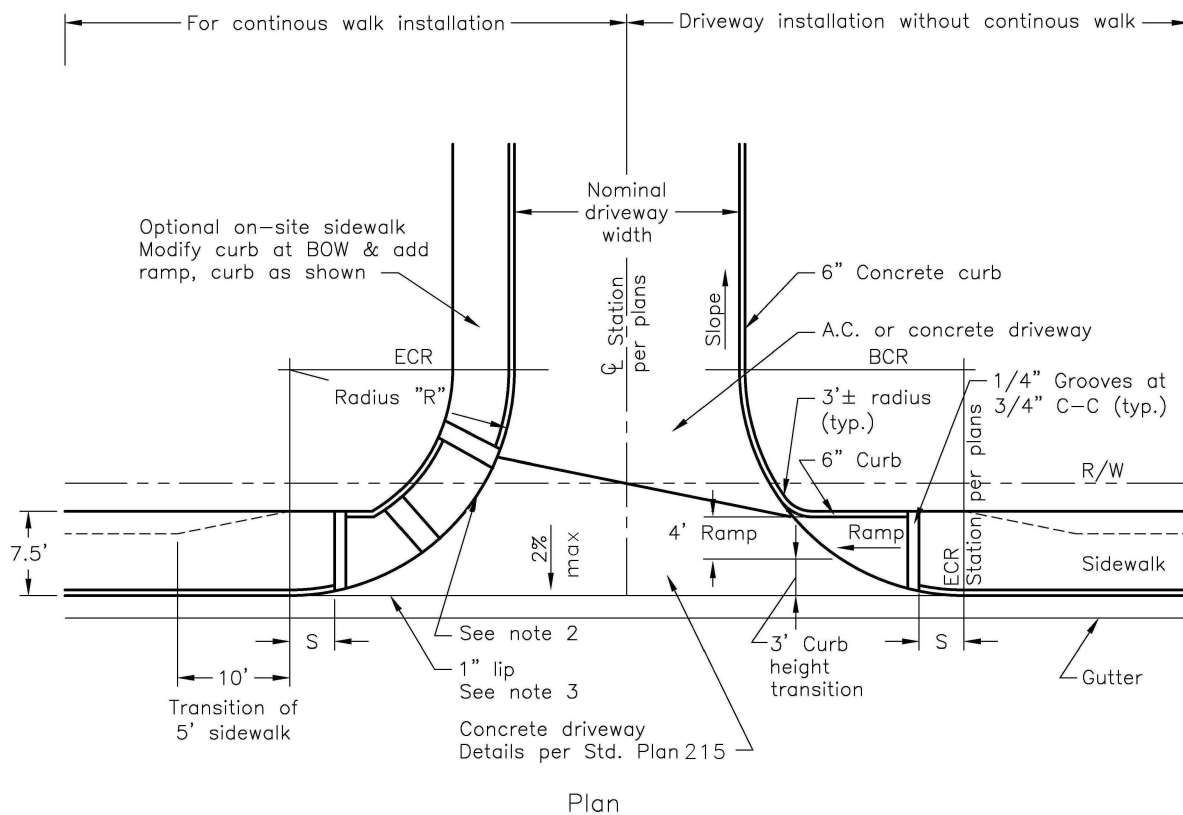

"R"	"S"
15'	3'
20'	4'
25'	5'
30'	6'
35'	7'

NOTES:

1. SPECIAL COMMERCIAL DRIVEWAY TO BE USED ONLY WHERE REQUIRED OR SPECIFICALLY APPROVED BY THE PUBLIC WORKS DIRECTOR.
2. SEE STANDARD PLAN 218 FOR WHEELCHAIR RAMP DETAILS.
3. PROVIDE IN-LINE CATCH BASIN IF DEPTH OF FLOW IN GUTTER EXCEEDS 3"
4. RAMPS TO COMPLY WITH THE MOST UP TO DATE ADA STANDARDS

NO.	REVISION	DATE	BY

DRAWN BY: BH, NR
 CHECKED BY: CD
 SCALE: NONE
 DATE: 03/2015

SPECIAL COMMERCIAL DRIVEWAY

CITY OF RIO VISTA
 DEPARTMENT OF PUBLIC WORKS

APPROVED BY:	DECEMBER 2015
CECIL DILLON	
CITY ENGINEER	DATE
RCE 25835	
STANDARD PLAN NO.	216

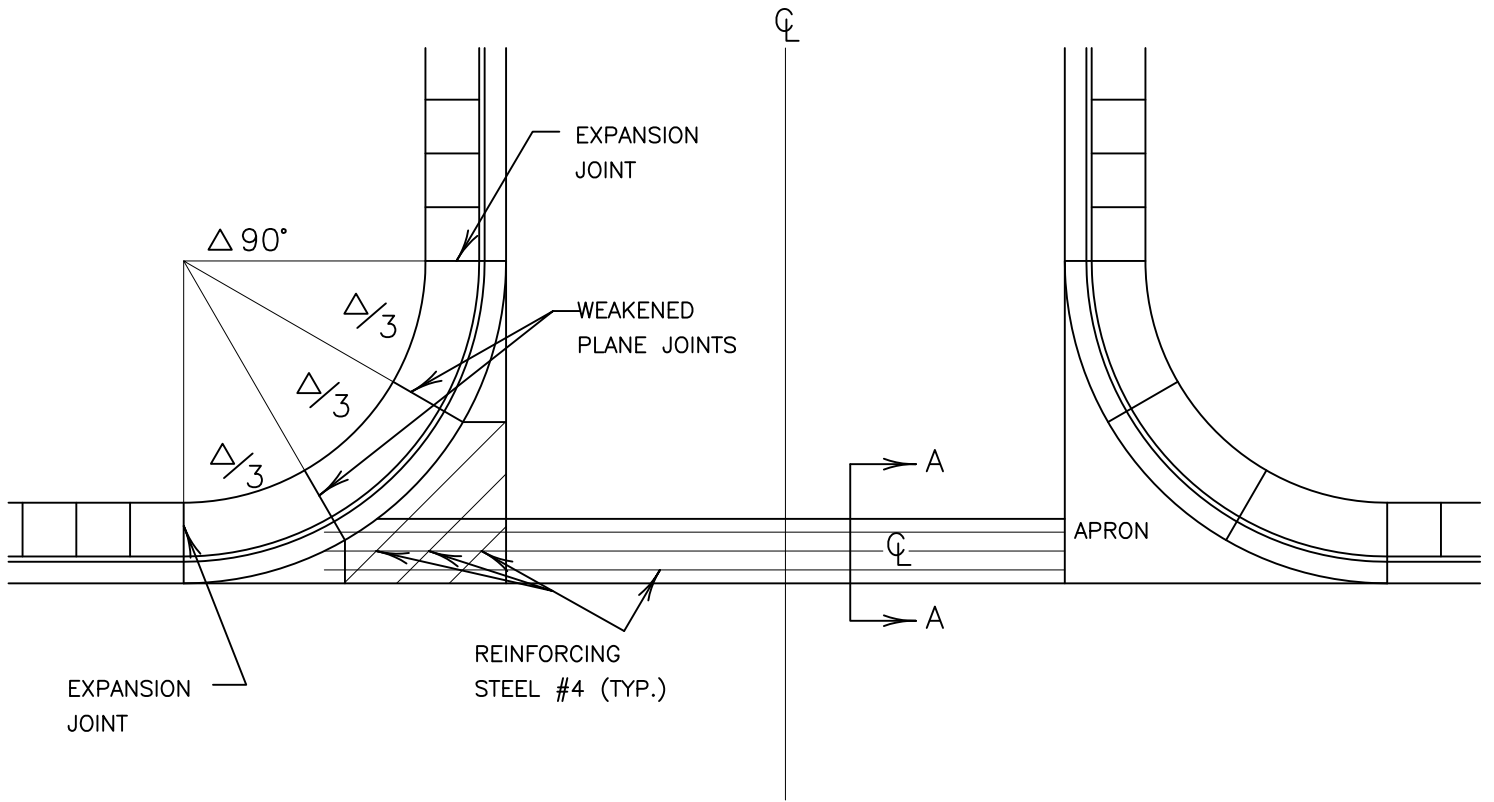

PLAN VIEW

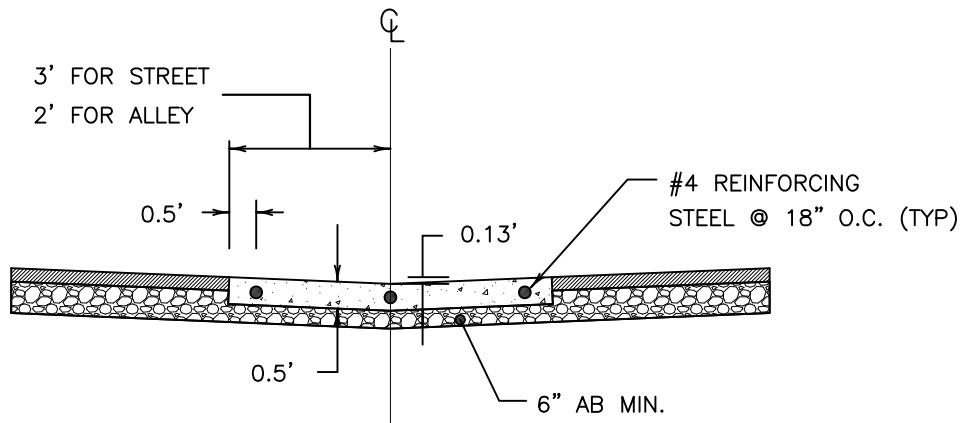

DETAIL A-A

NOTE:

1. VALLEY GUTTERS ALLOWED BY SPECIAL PERMISSION ONLY
2. LAP ALL REINFORCING STEEL 30 TIMES DIAMETERS.

NO.	REVISION	DATE	BY
DRAWN BY: BH, NR			
CHECKED BY: CD			
SCALE: NONE			
DATE: 03/2015			

VALLEY GUTTER	
CITY OF RIO VISTA	
DEPARTMENT OF PUBLIC WORKS	

APPROVED BY:	DECEMBER
CECIL DILLON	2015
CITY ENGINEER	DATE
RCE 25835	
STANDARD PLAN NO.	217

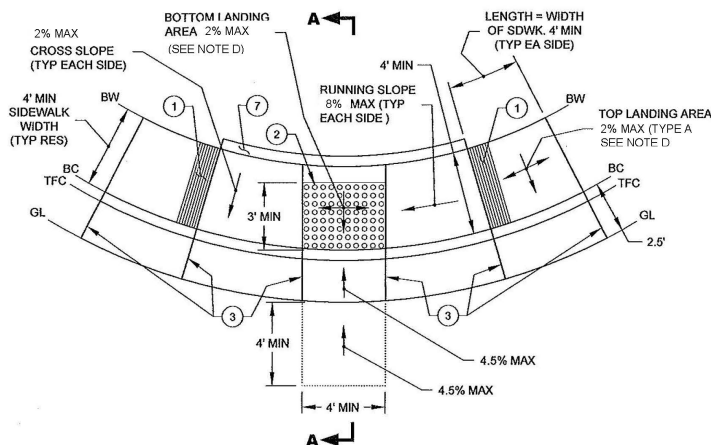

HANDICAP RAMP 1

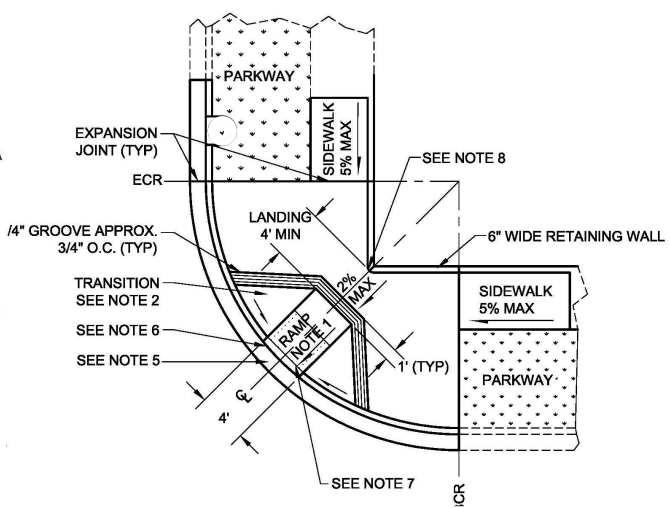

HANDICAP RAMP 2

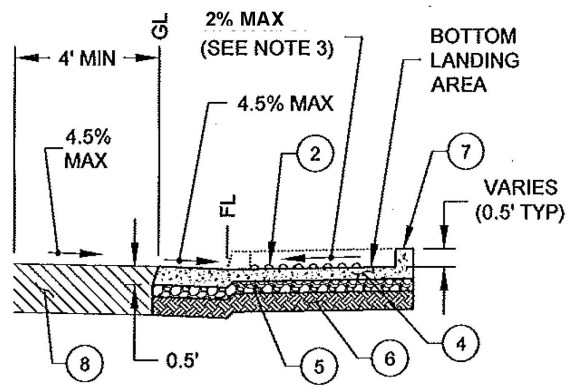

HANDICAP RAMP 1, SECTION A-A

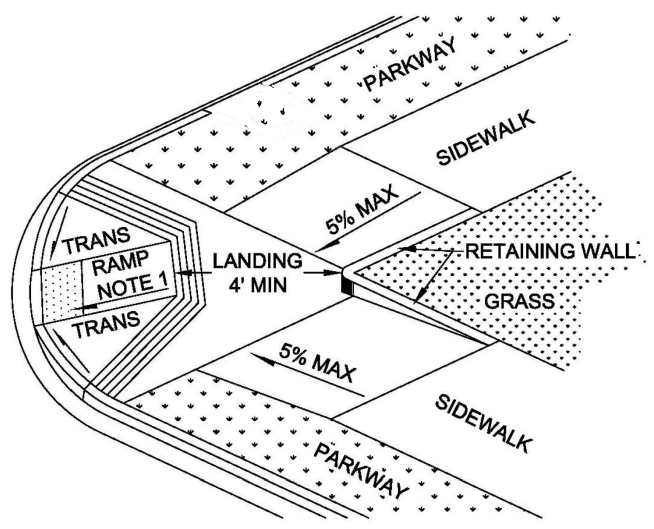

HANDICAP RAMP 2 ISOMETRIC

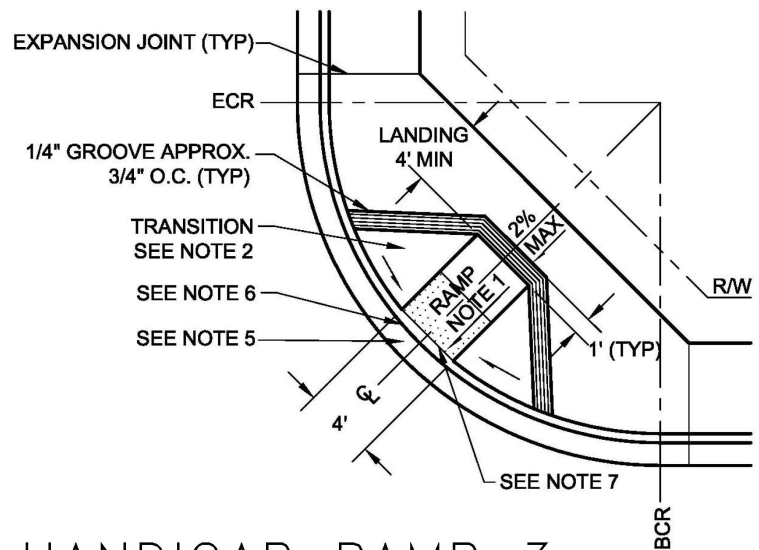

HANDICAP RAMP 3

NO.	REVISION	DATE	BY

DRAWN BY: BH, NR
 CHECKED BY: CD
 SCALE: NONE
 DATE: 03/2015

HANDICAP RAMP

CITY OF RIO VISTA
 DEPARTMENT OF PUBLIC WORKS

APPROVED BY: **CECIL DILLON**
 CITY ENGINEER
 RCF 25835

DECEMBER 2015
 DATE

STANDARD PLAN NO. 218

NOTES FOR HANDICAP RAMP 1:

- A. SLOPES MAY BE CHECKED WITH A 2-FOOT SMART LEVEL.
- B. RAMPS SHALL HAVE A HEAVY BROOM FINISH TRANSVERSE TO THEIR SLOPE.
- C. NO PULLBOX, UTILITY VAULT, UTILITY POLE, MANHOLE OR SIMILAR APPURTENANCE SHALL BE LOCATED WITHIN THE RAMP AREA WITHOUT PRIOR WRITTEN APPROVAL BY THE CITY ENGINEER.
- D. THE LANDING AREA SLOPE SHALL NOT EXCEED 2% IN ANY DIRECTION.
- E. TRANSITIONS TO SIDEWALK, GUTTER, AND STREETS SHALL BE FLUSH AND FREE OF ABRUPT CHANGE.
- F. RAMP SHALL BE DESIGNED AND CONSTRUCTED SUCH THAT WATER DOES NOT ACCUMULATE ON RAMP.
- G. THE LEADING EDGE OF THE DETECTABLE WARNING SURFACE SHALL BE LOCATED 6" TO 8" FROM THE GUTTER FLOW-LINE. DETECTABLE WARNING SURFACES SHALL BE INSTALLED PARALLEL TO THE PATH OF TRAVEL, AND SHALL EXTEND THE FULL WIDTH OF THE LANDING AREA. AND A MINIMUM DEPTH OF 3' FROM THE LEADING EDGE TOWARDS THE BACK OF THE LANDING AREA.
1. 12" BORDER WITH 1/4" GROOVES 3/4" ON CENTER PLACED ADJACENT LEVEL SIDEWALK (AKA TOP LANDING AREA), NOT ON SLOPED CURB RAMP. (SEE STANDARD DETAIL 221).
2. DETECTABLE WARNING SURFACE (SEE STANDARD DETAIL 221 AND NOTE G ABOVE).
3. DEEP TOOL JOINT-1 1/2" MIN DEPTH.
4. 4" CLASS 2 CONCRETE
5. 6" CLASS II AB PROCESSED TO 95% RELATIVE COMPACTION.
6. 6" SUBGRADE OR CLASS II AB PROCESSED TO 95% RELATIVE COMPACTION.
7. 6" WIDE RETAINING CURB WITH VARIABLE HEIGHT ALONG RUNNING SLOPE.
8. STRUCTURAL STREET SECTION PER DESIGN STANDARDS.

NOTES FOR HANDICAP RAMP 2:

1. RAMP SLOPE FROM 1:12 MAXIMUM TO 1:15 MINIMUM.
2. TRANSITION SLOPE 1:10 MAXIMUM.
3. CENTER RAMP ON MIDPOINT OF CURB RETURN.
4. THE CONCRETE FINISH OF THE RAMP SHALL HAVE A TRANSVERSE BROOMED SURFACE TEXTURE ROUGHER THAN THE SURROUNDING SIDEWALK.
5. THE GUTTER PAN ACROSS THE ROUTE OF TRAVEL, FROM THE RAMP TO THE STREET, SHALL HAVE A MAXIMUM SLOPE OF 5%.
6. ALL HANDICAP RAMPS SHALL HAVE NO LIP AND 1/4" DEEP SCORELINE ACROSS THE RAMP AT GUTTER FLOWLINE.
7. DETECTABLE WARNING SURFACE TO BE INSTALLED 6" TO 8" FROM GUTTER FLOWLINE AND EXTEND 36 INCHES MINIMUM IN THE DIRECTION OF TRAVEL AND THE FULL WIDTH OF THE CURB RAMP.
8. RETAINING WALL AT BACK OF RAMP SHALL BE CONSTRUCTED WITH A 6" RADIUS AT THE CORNER AND MAINTAIN EXISTING BACK OF WALK ELEVATIONS.
9. REFER TO STANDARD DETAIL 221 FOR RAISED TRUNCATED DOME DETAILS.

NOTES FOR HANDICAP RAMP 3:

1. RAMP SLOPE 1:12 MAXIMUM.
2. TRANSITION SLOPE 1:10 MAXIMUM.
3. CURB RETURN RADIUS PER PLANS. CENTER OF RAMP ON MIDPOINT OF CURB RETURN.
4. THE CONCRETE FINISH OF THE RAMP SHALL HAVE A TRANSVERSE BROOMED SURFACE TEXTURE ROUGHER THAN THE SURROUNDING SIDEWALK.
5. THE GUTTER PAN ACROSS THE ROUTE OF TRAVEL, FROM THE RAMP TO THE STREET, SHALL HAVE A MAXIMUM SLOPE OF 5%.
6. ALL HANDICAP RAMPS SHALL HAVE NO LIP AND 1/4" DEEP SCORELINE ACROSS THE RAMP AT GUTTER FLOWLINE.
7. DETECTABLE WARNING SURFACE TO BE INSTALLED 6" TO 8" FROM GUTTER FLOWLINE AND EXTEND 36 INCHES MINIMUM IN THE DIRECTION OF TRAVEL AND THE FULL WIDTH OF THE CURB RAMP.
9. REFER TO STANDARD DETAIL 221 FOR RAISED TRUNCATED DOME DETAILS.

NO.	REVISION	DATE	BY	HANDICAP RAMP NOTES	APPROVED BY:	DECEMBER
					CECIL DILLON	2015
DRAWN BY: BH, NR				CITY OF RIO VISTA DEPARTMENT OF PUBLIC WORKS	CITY ENGINEER	DATE
CHECKED BY: CD					RCE 25835	
SCALE: NONE					STANDARD	219
DATE: 03/2015					PLAN NO.	

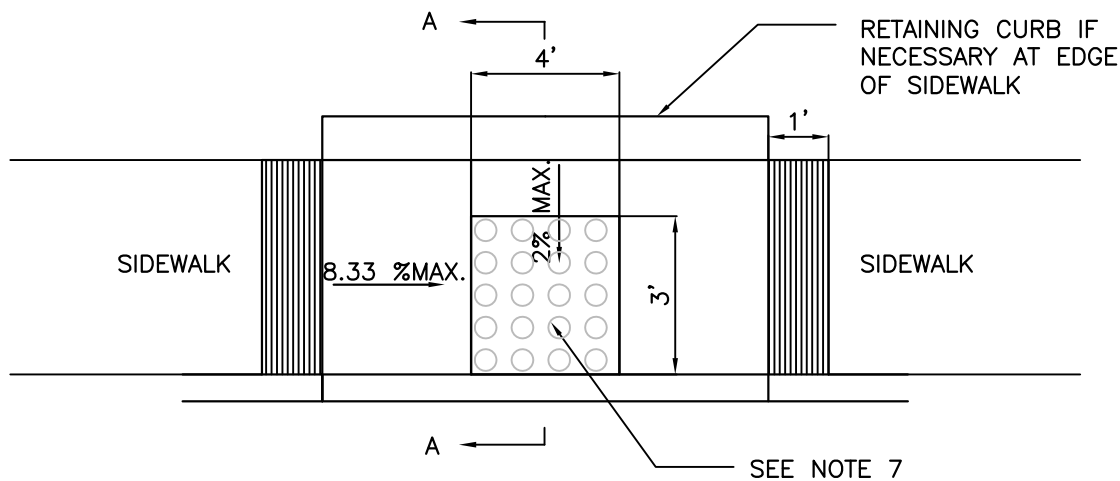

MIDBLOCK 1

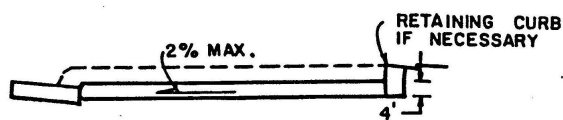

MIDBLOCK 1 SECTION A-A

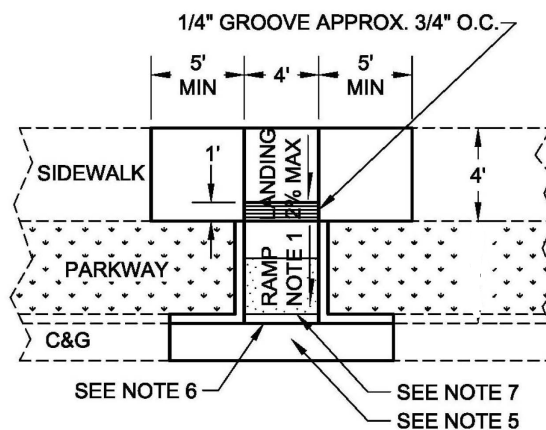

MIDBLOCK 2

NOTES FOR MIDBLOCK 1 & MIDBLOCK 2:

1. RAMP SLOPE 1:12 MAXIMUM.
2. TRANSITION SLOPE 1:10 MAXIMUM.
3. CURB RETURN RADIUS PER PLANS. CENTER OF RAMP ON MIDPOINT OF CURB RETURN.
4. THE CONCRETE FINISH OF THE RAMP SHALL HAVE A TRANSVERSE BROOMED SURFACE TEXTURE ROUGHER THAN THE SURROUNDING SIDEWALK.
5. THE GUTTER PAN ACROSS THE ROUTE OF TRAVEL, FROM THE RAMP TO THE STREET, SHALL HAVE A MAXIMUM SLOPE OF 4.5%.
6. ALL HANDICAP RAMPS SHALL HAVE NO LIP AND 1/4" DEEP SCORELINE ACROSS THE RAMP AT GUTTER FLOWLINE.
7. DETECTABLE WARNING SURFACE TO BE INSTALLED 6" TO 8" FROM GUTTER FLOWLINE AND EXTEND 36 INCHES MINIMUM IN THE DIRECTION OF TRAVEL AND THE FULL WIDTH OF THE CURB RAMP.
9. REFER TO STANDARD DETAIL 221 FOR RAISED TRUNCATED DOME DETAILS.

NO.	REVISION	DATE	BY
DRAWN BY: BH, NR			
CHECKED BY: CD			
SCALE: NONE			
DATE: 03/2015			

HANDICAP RAMP NOTES

CITY OF RIO VISTA
DEPARTMENT OF PUBLIC WORKS

APPROVED BY: CECIL DILLON
CITY ENGINEER
RCE 25835

DECEMBER 2015
DATE

STANDARD PLAN NO. 220

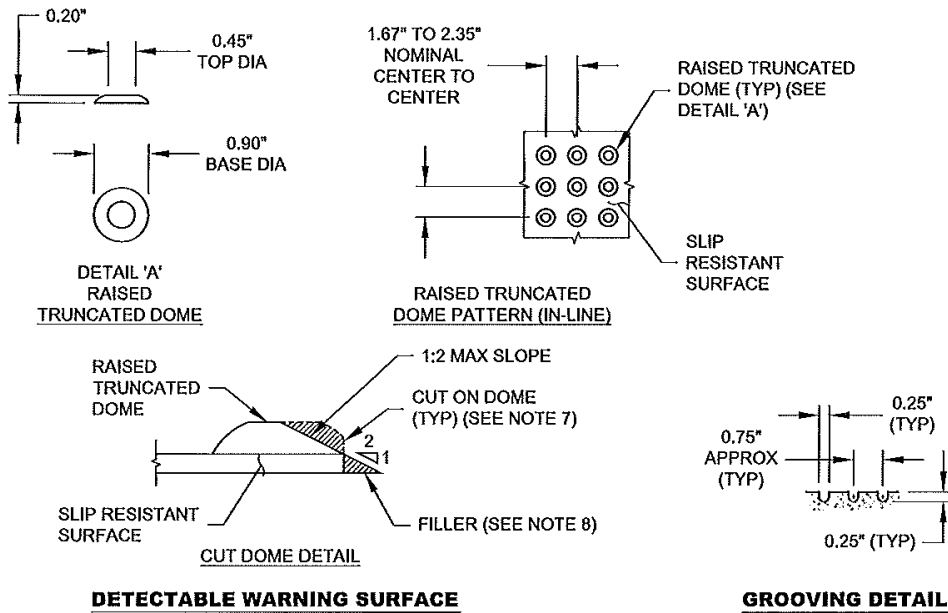

DETECTABLE WARNING SURFACE

GROOVING DETAIL

NOTES:

1. DETECTABLE WARNING SURFACES SHALL BE PRE-FABRICATED VITRIFIED POLYMER COMPOSITE MATERIAL, AS MANUFACTURED BY ARMOR-TILE, OR APPROVED EQUAL.
2. TRUNCATED DOMES SHALL HAVE DIMENSIONS OF 0.20" HEIGHT, 0.9" BASE DIAMETER, AND BE SPACED AT 1.67" ON CENTER TO 2.35" ON CENTER.
3. DETECTABLE WARNING SURFACES SHALL CONTRAST VISUALLY BY AT LEAST 70% WITH ADJACENT SURFACES, EITHER LIGHT-ON-DARK OR DARK-ON-LIGHT. STANDARD COLOR FOR THE DETECTABLE WARNING SURFACE SHALL BE FEDERAL YELLOW (NO.33538) UNLESS OTHERWISE APPROVED BY THE CITY ENGINEER.
4. DETECTABLE WARNING SURFACES SHALL BE SLIP RESISTANT.
5. DETECTABLE WARNING PAD INSTALLATIONS SHALL UTILIZE CAST-IN-PLACE PRODUCTS AND INSTALLATION METHOD FOR ALL NEW INSTALLATIONS WITHOUT EXCEPTIONS. SURFACE MOUNT PRODUCTS AND INSTALLATION METHOD MAY BE USED FOR RETROFIT SITUATIONS WITH PRIOR WRITTEN APPROVAL OF THE CITY ENGINEER. ALL PRODUCTS AND INSTALLATION METHODS SHALL CONFORM TO THESE SPECIFICATIONS AND DETAILS AND MANUFACTURER RECOMMENDATIONS.
6. ALL DETECTABLE WARNING PRODUCTS MUST COME WITH A 5-YEAR WARRANTY FOR SHAPE, COLOR FASTNESS, SOUND-ON-CANE ACOUSTIC QUALITY, RESILIENCE AND ATTACHMENT. WARRANTY MUST STATE THAT PRODUCT AND ATTACHMENT WILL NOT DEGRADE SIGNIFICANTLY FOR 5 YEARS, I.E. MUST RETAIN AT LEAST 90% OF ITS ORIGINAL APPROVED DESIGN CHARACTERISTICS.
7. THE EDGE OF THE DETECTABLE SURFACE SHALL HAVE A BEVELED EDGE SLOPE AT 1:2 MAXIMUM. WHEN THE DETECTABLE SURFACE EDGE IS CUT AND THE RESULTING EDGE IS NOT FLUSH WITH THE SURFACE OF THE CURB RAMP, THE EDGE SHALL BE BEVELED OR CONFORMED WITH AN APPROVED FILLER AT 1:2 MAXIMUM SLOPE, IN ACCORDANCE WITH THE APPROVED DETECTABLE SURFACE MANUFACTURER'S REQUIREMENTS.

NO.	REVISION	DATE	BY	CURB RAMP GROOVINGS AND DETECTABLE WARNING SURFACE	APPROVED BY:	DECEMBER
					CECIL DILLON	2015
DRAWN BY: BH, NR				CITY OF RIO VISTA DEPARTMENT OF PUBLIC WORKS	CITY ENGINEER	DATE
CHECKED BY: CD					RCE 25835	
SCALE: NONE					STANDARD	221
DATE: 03/2015				PLAN NO.		

SCALE:  N.T.S.

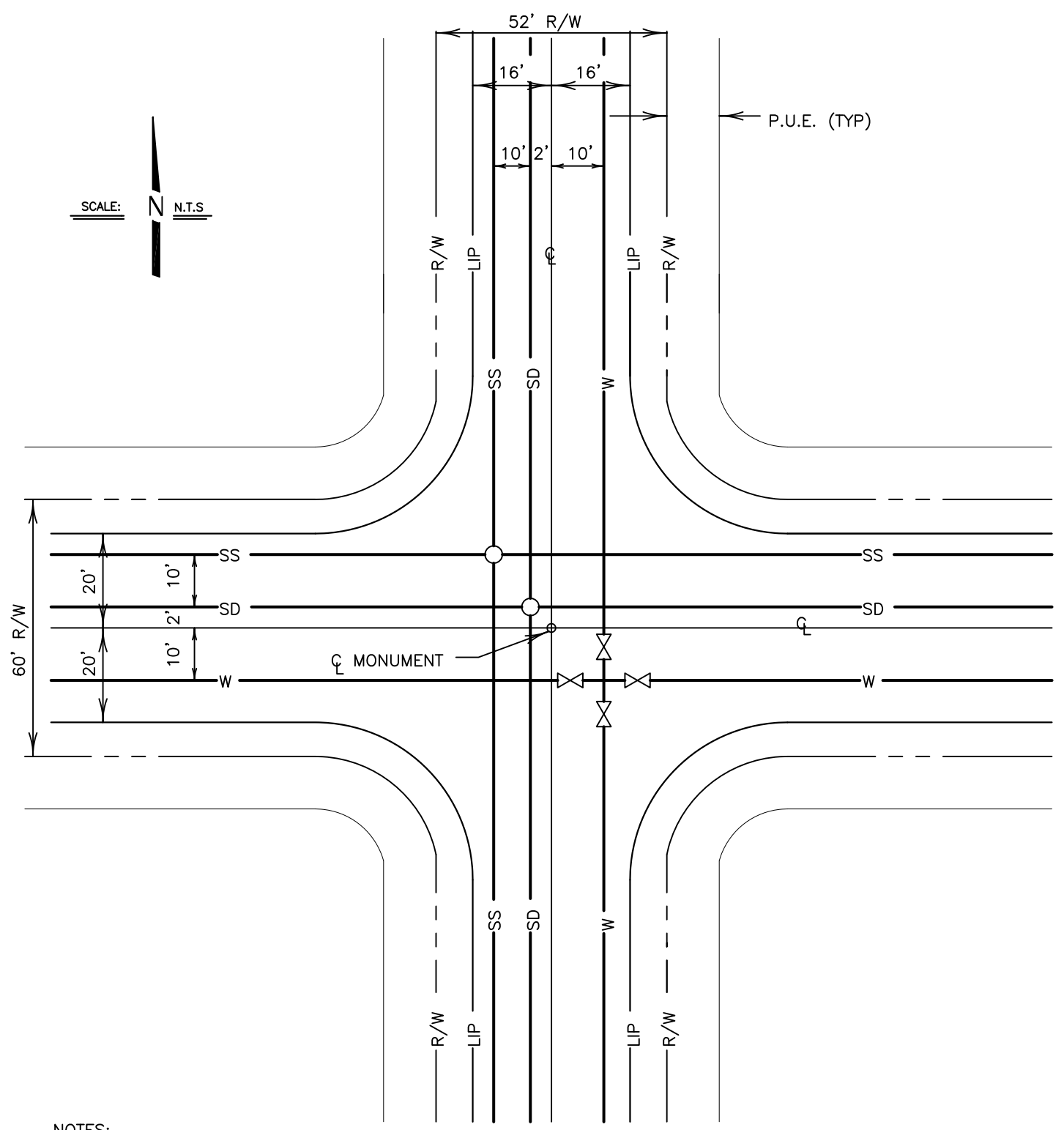

NOTES:

1. ANY DEVIATION FROM THE STANDARD LOCATION SHALL BE APPROVED BY THE CITY ENGINEER.
2. THIS STANDARD SHALL APPLY TO NEW DEVELOPMENTS.
3. FRANCHISE UTILITIES TELEPHONE, GAS, ELECTRICAL, TELEVISION CABLE, ETC. SHALL BE LOCATED IN THE P.U.E. AREA.

NO.	REVISION	DATE	BY

DRAWN BY: BH, NR
 CHECKED BY: CD
 SCALE: NONE
 DATE: 03/2015

**STANDARD UTILITY LOCATION
IN STREET**

CITY OF RIO VISTA
DEPARTMENT OF PUBLIC WORKS

APPROVED BY: **CECIL DILLON** DECEMBER 2015
 CITY ENGINEER
 RCF 25835 DATE

STANDARD PLAN NO. 222

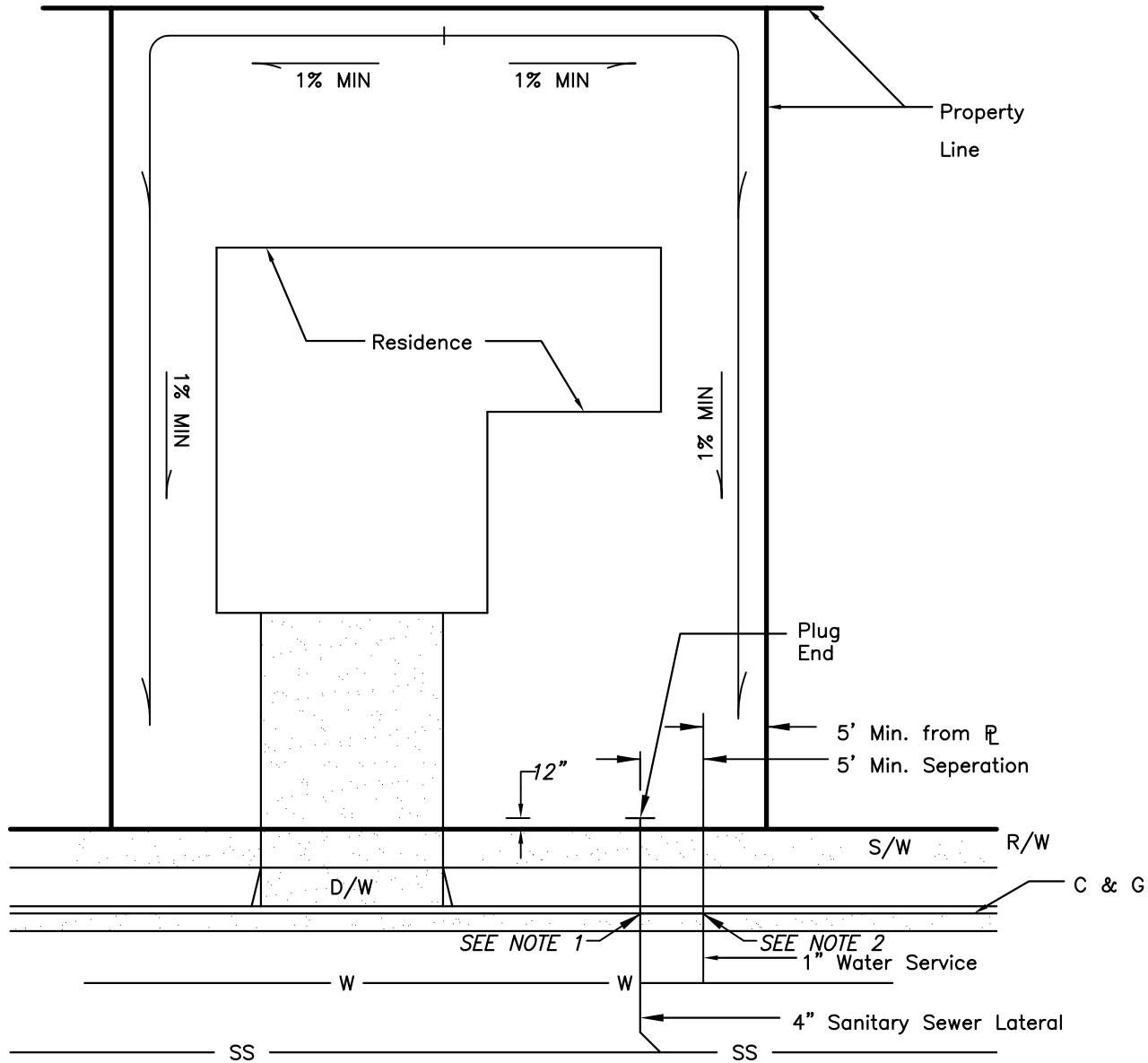

PLAN: LOT UTILITY LOCATION

NOTES:

1. A 2"x2" LETTER "S" SHALL BE STAMPED, CHISELED, CUT, ETC. ON THE TOP OF ALL CONCRETE CURBS ON ALL SANITARY SEWER LATERALS DIRECTLY ABOVE THE LOCATION WHERE THE LATERAL CROSSES THE FLOW LINE OF THE GUTTER.
2. A 2"x2" LETTER "W" SHALL BE STAMPED, CHISELED, CUT, ETC. ON THE TOP OF ALL CONCRETE CURBS ON ALL WATER SERVICES DIRECTLY ABOVE THE LOCATION WHERE THE SERVICE CROSSES THE FLOW LINE OF THE CONCRETE GUTTER.

NO.	REVISION DATE	BY	TYPICAL UTILITY SERVICE LAYOUT	APPROVED BY:	DECEMBER 2015
				CITY OF RIO VISTA DEPARTMENT OF PUBLIC WORKS	CECIL DILLON CITY ENGINEER RCF 25835
DRAWN BY: BH, NR			STANDARD PLAN NO. 223		
CHECKED BY: CD					
SCALE: NONE					
DATE: 03/2015					

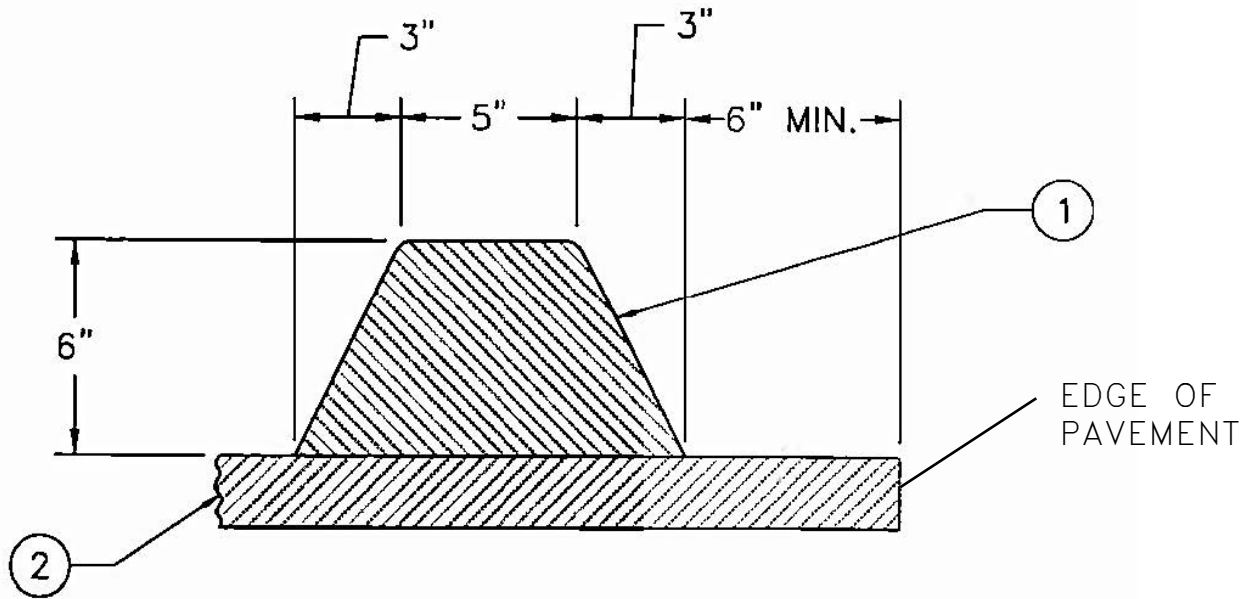

1. ASPHALT CONCRETE DIKE SHALL BE INSTALLED IN CONFORMANCE WITH SECTION 39-1.14 OF THE STATE STANDARD SPECIFICATIONS.

2. ASPHALT CONCRETE PAVEMENT.

NOTES:

A. ASPHALTIC EMULSION SHALL BE USED BETWEEN DIKE AND AC PAVEMENT.

NO.	REVISION	DATE	BY
DRAWN BY: BH, NR			
CHECKED BY: CD			
SCALE: NONE			
DATE: 03/2015			

ASPHALT CONCRETE DIKE

CITY OF RIO VISTA
DEPARTMENT OF PUBLIC WORKS

APPROVED BY:	DECEMBER
CECIL DILLON	2015
CITY ENGINEER	DATE
RCE 25835	

STANDARD
PLAN NO. **224**

CURB PARKING

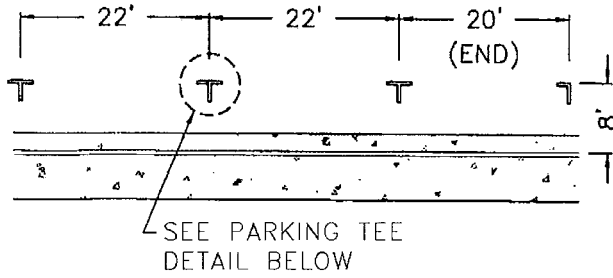

INTERIOR AND END

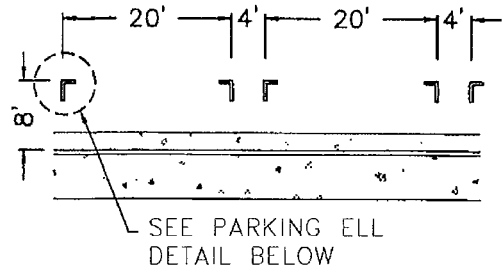

PAIRED PARKING

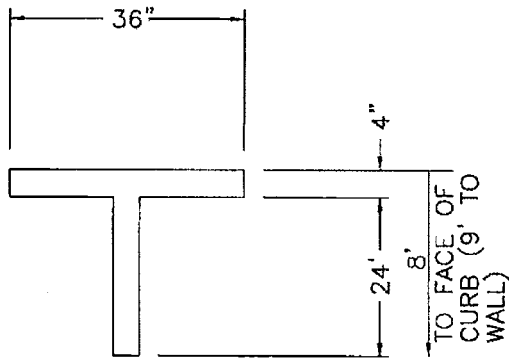

PARKING TEE

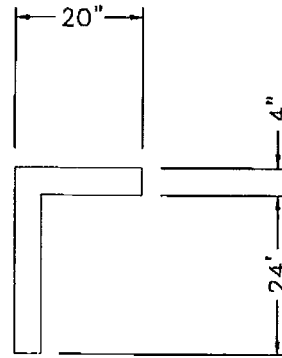

PARKING ELL

NOTES:

STRIPING FOR PARKING SPACE DELINEATION SHALL BE THERMOPLASTIC.

NO.	REVISION DATE	BY	PARALLEL PARKING SPACES CITY STREET	APPROVED BY:	DECEMBER 2015
				CECIL DILLON	DATE
DRAWN BY: BH, NR				CITY ENGINEER	
CHECKED BY: CD				RCE 25835	
SCALE: NONE			CITY OF RIO VISTA	STANDARD	225
DATE: 03/2015			DEPARTMENT OF PUBLIC WORKS	PLAN NO.	

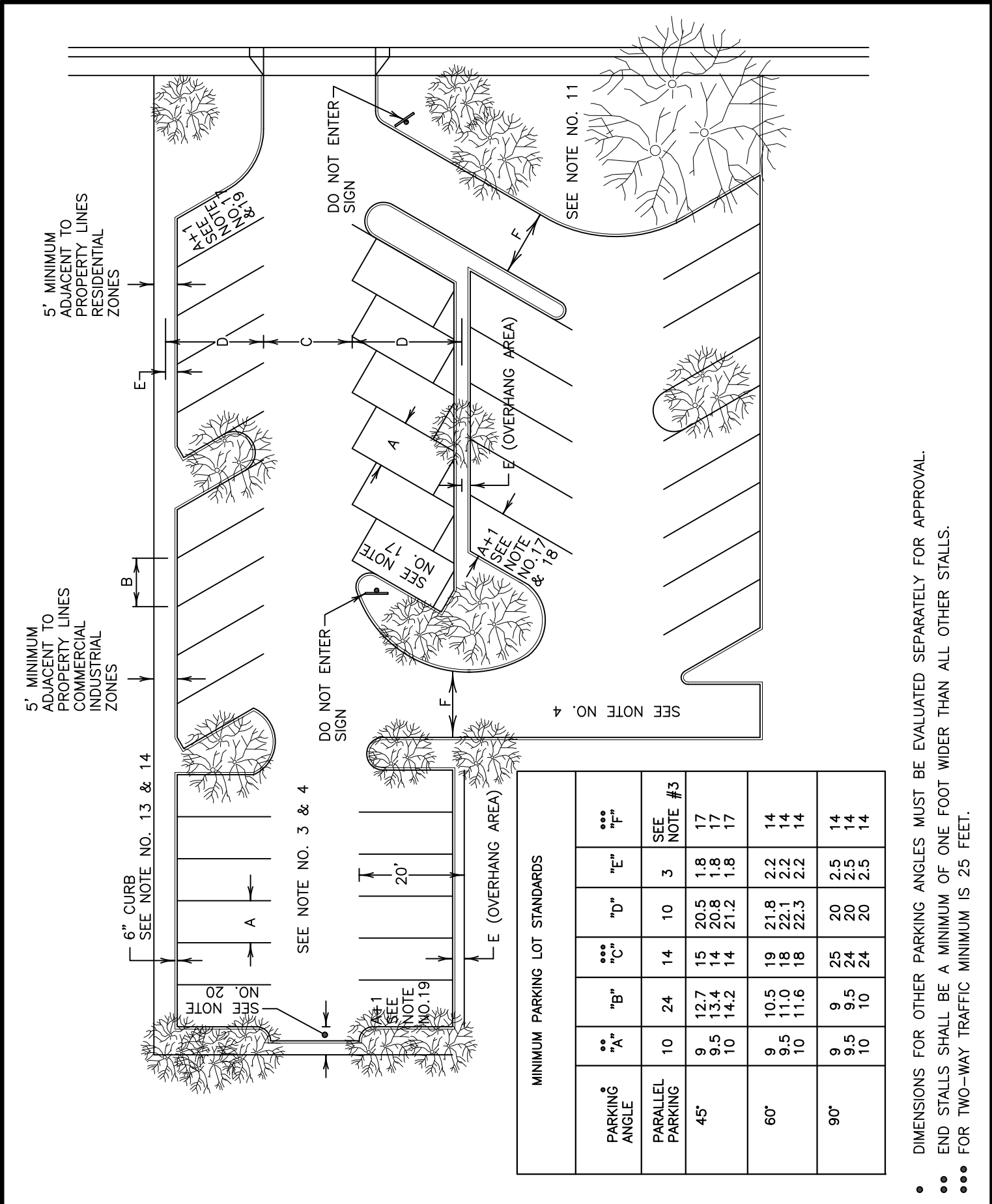

- DIMENSIONS FOR OTHER PARKING ANGLES MUST BE EVALUATED SEPARATELY FOR APPROVAL.
- END STALLS SHALL BE A MINIMUM OF ONE FOOT WIDER THAN ALL OTHER STALLS.
- FOR TWO-WAY TRAFFIC MINIMUM IS 25 FEET.

NO.	REVISION	DATE	BY

DRAWN BY: BH, NR
 CHECKED BY: CD
 SCALE: NONE
 DATE: 03/2015

PARKING STANDARDS

CITY OF RIO VISTA

DEPARTMENT OF PUBLIC WORKS

APPROVED BY: **CECIL DILLON** DECEMBER 2015
 CITY ENGINEER DATE
 RCF 25835

STANDARD PLAN NO. 226

PARKING STANDARD NOTES

1. A MINIMUM NUMBER OF PARKING SPACES REQUIRED IS ESTABLISHED BY THE CITY OF RIO VISTA ZONING ORDINANCE.
2. ALL PARKING STALLS SHALL BE MARKED IN A ACCEPTABLE MANNER.
3. LOTS DESIGNED FOR MORE THAN FOUR CARS MUST HAVE TWO-WAY ACCESS
4. WHERE TWO PARKING ANGLES ARE TO BE USED IN A SINGLE LOT, THEY SHALL BE LOCATED IN SEPARATE AREAS OF THE LOT (CITY CAN MAKE EXCEPTIONS IF VALID CIRCUMSTANCES EXIST).
5. ANY PARKING LAYOUT NECESSITATING A CUL-DE-SAC OR SIMILAR TYPE OF TURNING FACILITY FOR REVERSING DIRECTION OF TRAVEL IN ORDER TO EXIT FROM THE AREA OR ANY PARKING SPACES WILL GENERALLY BE DISCOURAGED, AND IT SHOULD BE APPROVED BY THE CITY STAFF PRIOR TO THE INCORPORATION INTO THE PLAN.
6. RESIDENTIAL PARKING FOR MORE THAN FOUR CARS AND PARKING IN COMMERCIAL AND INDUSTRIAL AREAS SHALL NOT BE DESIGNED TO REQUIRE BACKING OUT ONTO ANY PUBLIC STREET RIGHT-OF-WAY.
7. TWO-WAY TRAFFIC AISLES SHALL BE A MINIMUM OF 24 FEET WIDE.
8. PARKING OR BACKING AREA WITHIN A PARKING LOT SHALL NOT EXTEND INTO THE PUBLIC RIGHT-OF-WAY.
9. WHEN A LONG DRIVEWAY HAVING ONLY A SINGLE INGRESS IS NECESSARY WITHIN A DEVELOPMENT, PROVISIONS SHOULD BE MADE FOR THE MANEUVERING OF EMERGENCY VEHICLES AND THE ARRANGEMENT APPROVED BY CITY STAFF PRIOR TO ITS INCORPORATION INTO THE PLAN.
10. ALL PARKING LOTS SHALL HAVE AN ADEQUATE STRUCTURAL SECTION AND SHALL BE PAVED WITH A MINIMUM OF TWO INCHES OF ASPHALT CONCRETE.
11. ALL UNUSABLE AREAS SHALL BE LANDSCAPED WHERE PRACTICAL.
12. LANDSCAPED AREAS WITHIN OR ADJACENT TO THE PARKING AREA SHALL PROVIDE FOR A MINIMUM OF ONE SHADE TREE FOR EVERY FOUR PARKING STALLS. DEPENDING ON TYPE AND SIZE OF SHADE TREE, REQUIREMENTS MAY BE MODIFIED BY THE CITY.
13. SIX-INCH HIGH CONCRETE CURBS SHALL SEPARATE ALL PAVED AND LANDSCAPED AREAS.
14. THE CONCRETE CURBING SHALL BE USED AS WHEEL STOPS WHERE POSSIBLE. THE USE OF BUMPER BLOCKS IS DISCOURAGED.
15. LANDSCAPED AREAS SHALL BE PROVIDED BETWEEN ASPHALT AREAS AND ALL BUILDING STRUCTURES AND FENCES AND PROPERTY LINES. HARDSCAPING MAY BE USED WHERE PEDESTRIAN ACCESS IS A NECESSITY AS DETERMINED BY THE CITY.
16. LANDSCAPING SHALL CONFORM TO THE CITY OF RIO VISTA LANDSCAPE GUIDELINES.
17. END STALLS SHOULD BE PROTECTED FROM THE TURNING MOVEMENT OF OTHER VEHICLES.
18. HANDICAPPED STALLS SHALL BE A MINIMUM OF NINE FEET WIDE PLUS AN ADJACENT FIVE FOOT MINIMUM ACCESS ZONE, PER TITLE 24, CHAPTER 2-7102, CALIFORNIA ADMINISTRATIVE CODE. VAN ACCESSIBLE STALLS SHALL HAVE A MINIMUM 8 FOOT ADJACENT ACCESS ZONE.
19. END STALLS ADJACENT TO CURBINGS SHALL BE A MINIMUM OF TEN FEET WIDE.
20. DEAD END 90° PARKING SHALL BE PROVIDED WITH ADEQUATE TURNING ROOM.
21. PARKING REQUIREMENTS FOR THE INTERIOR OF PARKING LOTS ON INDUSTRIAL LOTS SURROUNDED SOLELY BY HEAVY INDUSTRIALLY ZONED PROPERTIES MAY BE MODIFIED BY THE CITY.
22. ALL OFF-STREET PARKING STALLS SHALL BE PAVED.
23. ALL LANDSCAPED AREAS TO BE WITHOUT LAWN.

NO.	REVISION DATE	BY	PARKING STANDARD NOTES	APPROVED BY:	DECEMBER
				CECIL DILLON	2015
DRAWN BY: BH, NR			CITY OF RIO VISTA DEPARTMENT OF PUBLIC WORKS	CITY ENGINEER	DATE
CHECKED BY: CD				RCE 25835	
SCALE: NONE				STANDARD	227
DATE: 03/2015				PLAN NO.	

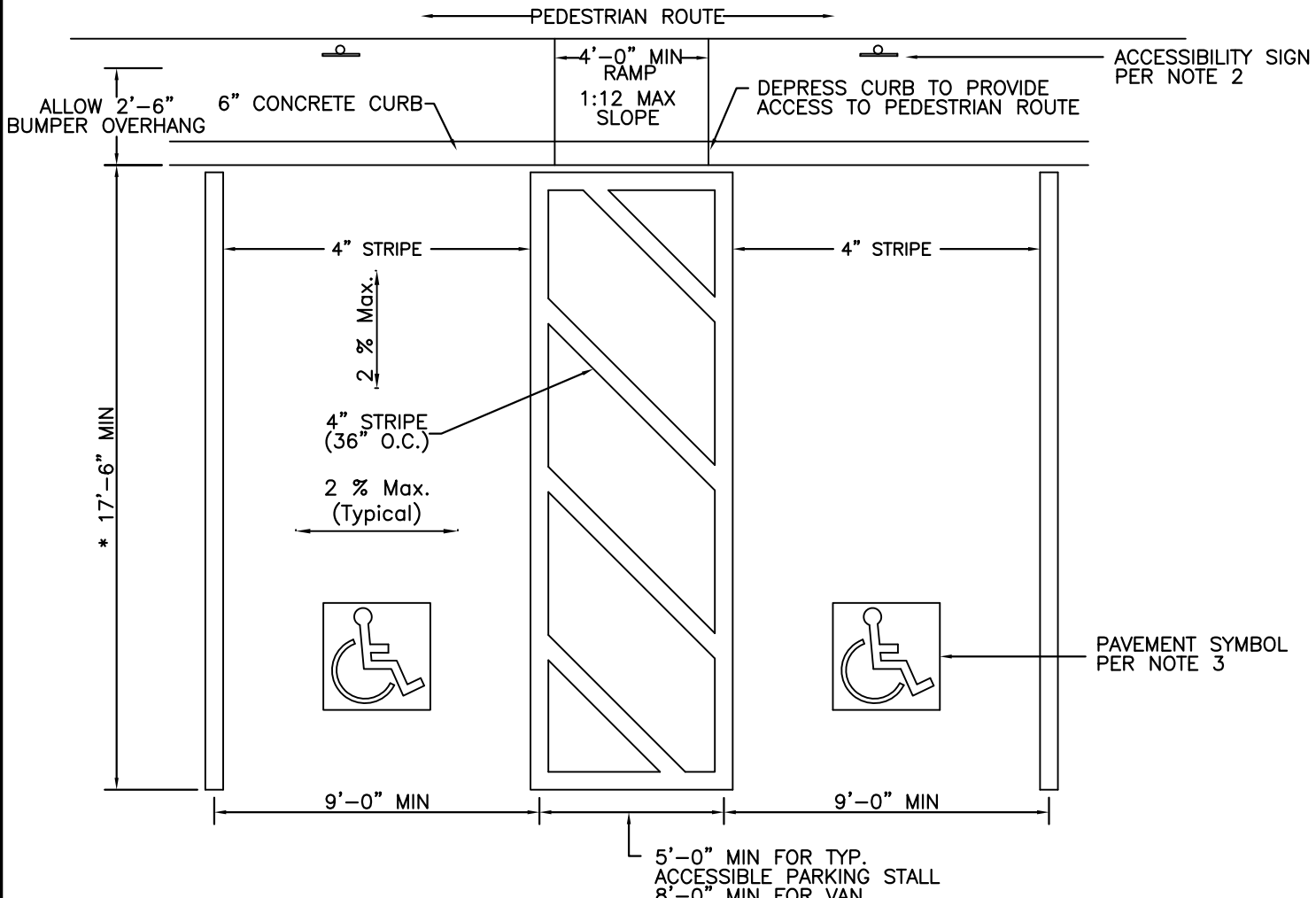

NOTES:

1. ONE IN EVERY EIGHT ACCESSIBLE SPACES, BUT NOT LESS THAN ONE, SHALL BE SERVED BY AN ACCESS AISLE 8' WIDE MINIMUM AND SHALL BE DESIGNATED VAN ACCESSIBLE.
 2. EACH PARKING SPACE RESERVED FOR PERSONS WITH PHYSICAL DISABILITIES SHALL BE IDENTIFIED BY A REFLECTORIZED SIGN IN ACCORDANCE WITH STATE STANDARD SIGN R99. VAN ACCESSIBLE PARKING SPACES SHALL BE IDENTIFIED BY REFLECTIVE SIGNS IN ACCORDANCE WITH STATE STANDARD SIGN R99 AND R99A. SIGNS SHALL BE POSTED AT A MINIMUM HEIGHT OF 80 INCHES FROM THE BOTTOM OF THE SIGN TO THE PARKING SPACE FINISH GRADE.
 3. PAVEMENT SYMBOL SHALL BE PER MUTCD CALIFORNIA EDITION.
 4. AN ADDITIONAL SIGN (17"x22") SHALL BE INSTALLED AT EACH ENTRANCE TO THE PARKING LOT. THE SIGN SHALL READ AS FOLLOWS: "UNAUTHORIZED VEHICLES PARKED IN DESIGNATED ACCESSIBLE SPACES NOT DISPLAYING DISTINGUISHING PLACARDS OR LICENSE PLATES ISSUED FOR PERSONS WITH DISABILITIES MAY BE TOWED AWAY AT OWNER'S EXPENSE. TOWED VEHICLES MAY BE RECLAIMED BY TELEPHONING THE CITY OF RIO VISTA POLICE DEPARTMENT"
 5. IF OVERHANG ENCROACHES ONTO A PEDESTRIAN AREA, PEDESTRIAN AREA SHALL HAVE A MINIMUM 4'-0" CLEAR WIDTH.
- * PARKING STALL SHALL BE 20'-0" LONG IF 2'-6" CURB OVERHANG IS NOT PROVIDED.

NO.	REVISION DATE	BY	HANDICAP PARKING LAYOUT	APPROVED BY:	DECEMBER 2015
				CECIL DILLON	DATE
DRAWN BY: BH, NR			CITY OF RIO VISTA DEPARTMENT OF PUBLIC WORKS	CITY ENGINEER	
CHECKED BY: CD				RCE 25835	
SCALE: NONE				STANDARD PLAN NO. 228	
DATE: 03/2015					

NOTES:

1. STOP SIGNS SHALL BE MUTCD (MANUAL ON UNIFORM TRAFFIC CONTROL DEVICES CALIFORNIA SUPPLEMENT) STANDARD R1-1 (30" BY 30" SIGN)
2. STREET-SIDE EDGE OF SIGN SHALL BE NOT LESS THAN 12" FROM FACE OF CURB.
3. ALL SIGNS ARE TO BE INSTALLED USING THEFT-PROOF HARDWARE
4. LIMIT LINES MAY BE AT AN ALTERNATIVE LOCATION WITH APPROVAL BY THE CITY.

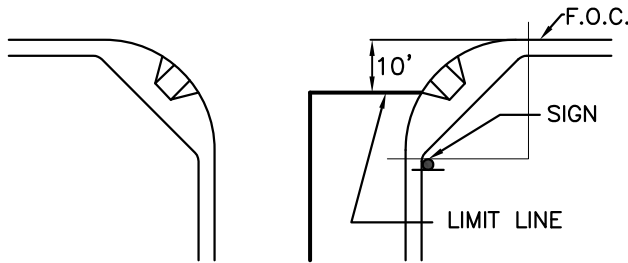
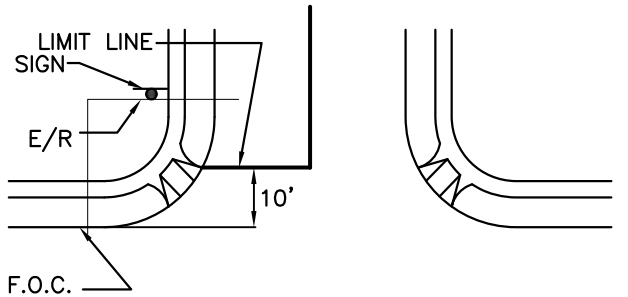
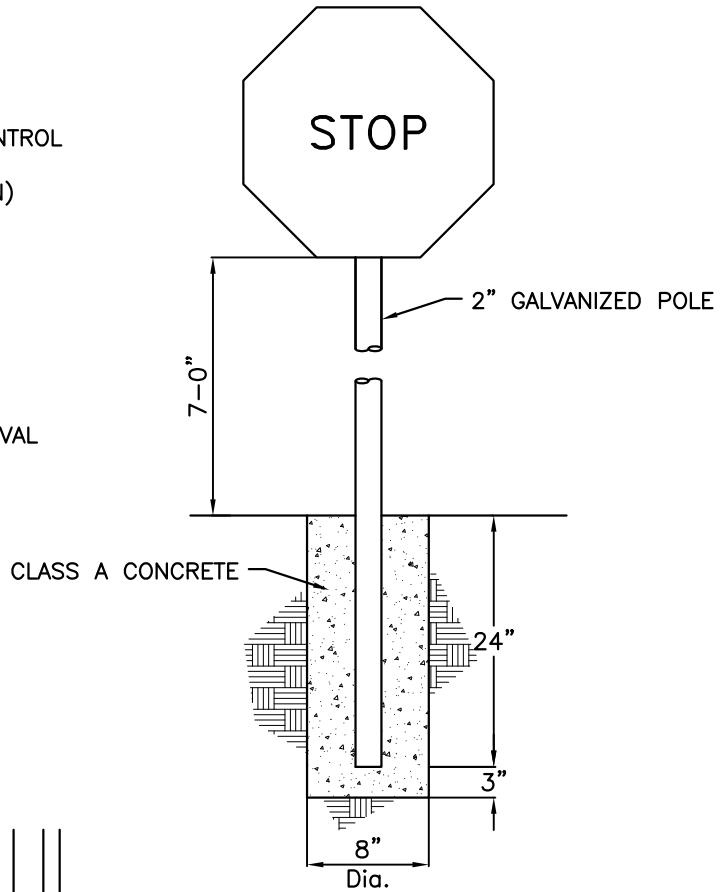

SIGN & LIMIT LINE LOCATION

NO.	REVISION	DATE	BY
DRAWN BY: BH, NR			
CHECKED BY: CD			
SCALE: NONE			
DATE: 03/2015			

STANDARD STOP SIGN

CITY OF RIO VISTA
DEPARTMENT OF PUBLIC WORKS

APPROVED BY:	DECEMBER
CECIL DILLON	2015
CITY ENGINEER	DATE
RCE 25835	

STANDARD PLAN NO. 229

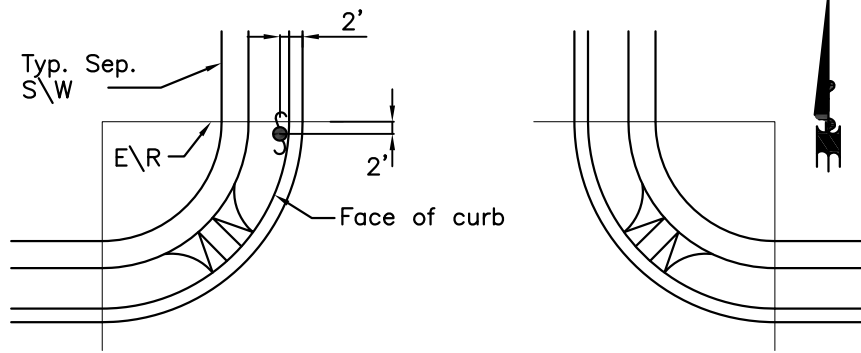

STREET SIGN PLACEMENT

NOTE: Street signs shall be placed at the N\W and S\E corners as shown unless otherwise directed by the City Engineer.

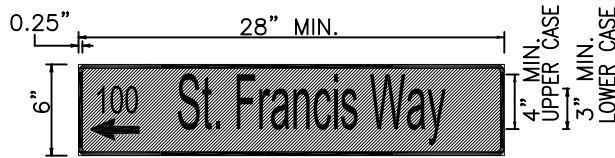
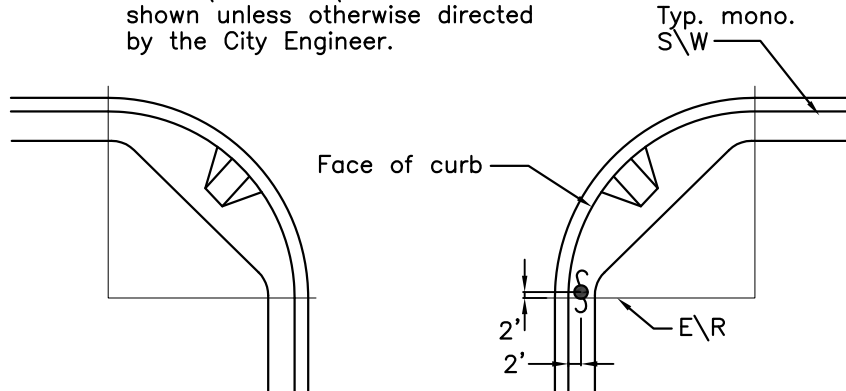

STREET SIGN DETAIL
NOT TO SCALE

NOTES:

1. GIL SANS CONDENSED FONT, COLOR WHITE.
2. FONT HEIGHT SHALL BE 4" UPPER CASE AND 3" LOWER CASE.
3. SIGN WIDTH SHALL BE 28" MIN.
4. SIGN HEIGHT SHALL BE 6".
5. SIGN BACKGROUND SHALL BE BLUE.

SPECIFICATIONS

1. ALL SIGNS SHALL CONFORM TO THE LATEST VERSION OF MUTCD-CA.
2. SIGN PLATES SHALL BE "SCOTCHLITE" REFLECTIVE SHEETING APPLIED TO DEGREASED AND ETCHED FB 118, .080 ALUMINUM BY 3M CO. OR EQUAL.
3. STREET NAME TO BE 4" UPPER CASE LETTERS WITH 3" LOWER CASE LETTERS. AVE., BLVD., CT., DR., PL., ST., & RD., MAY BE USED, LANE AND WAY NOT TO BE ABBREVIATED.
4. MOUNTING HARDWARE SHALL BE HAWKINS V14F--(HD)SL SERIES ALUMINUM HIGH TENSILE ALLOY BRACKETS OR APPROVED EQUAL.
5. THE BACKGROUND, LEGEND, AND BORDER OF THE SIGN SHALL BE HIGH INTENSITY PRISMATIC RETROREFLECTIVE VINYL SHEETING CONFORMING TO ASTM D4956, TYPE IV. THE BACKGROUND SHALL BE BLUE AND THE LEGEND AND BORDER SHALL BE WHITE.
6. STREET NAMES SIGNS SHALL BE LOCATED N/W AND S/E AS DIRECTED ABOVE.

NOTE:

WHEN STOP SIGN OR ANY OTHER SIGN ARE TO BE INSTALLED ON STREET SIGN POLE, HEIGHT OF SIGN SHALL HAVE PRECEDENCE. A 7'-0" MINIMUM CLEARANCE FROM BOTTOM OF SIGN TO TOP OF GROUND SHALL BE REQUIRED.

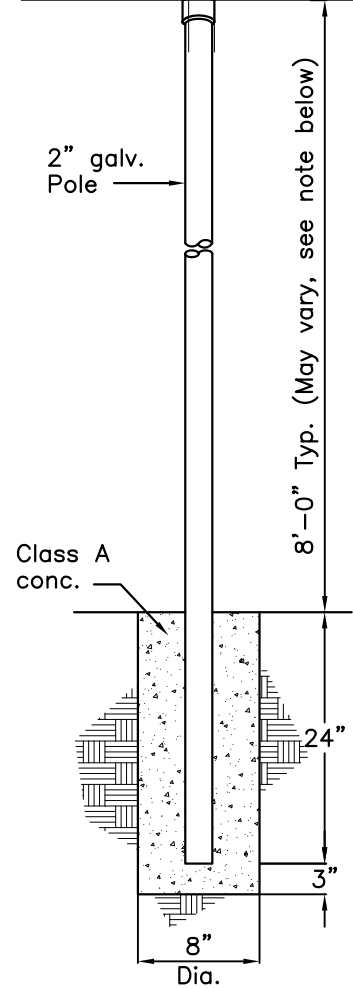

NO.	REVISION	DATE	BY
DRAWN BY: BH, NR			
CHECKED BY: CD			
SCALE: NONE			
DATE: 03/2015			

STANDARD STREET SIGN
CITY OF RIO VISTA DEPARTMENT OF PUBLIC WORKS

APPROVED BY:	DECEMBER
CECIL DILLON	2015
CITY ENGINEER	DATE
RCE 25835	
STANDARD PLAN NO.	230

FRAME AND COVER: G5 CHRISTY TRAFFIC RATED BOX OR APPROVED EQUAL. LID SHALL BE STAMPED "SURVEY MONUMENT"

SET FRAME TO GRADE

6" MIN.
12" MAX

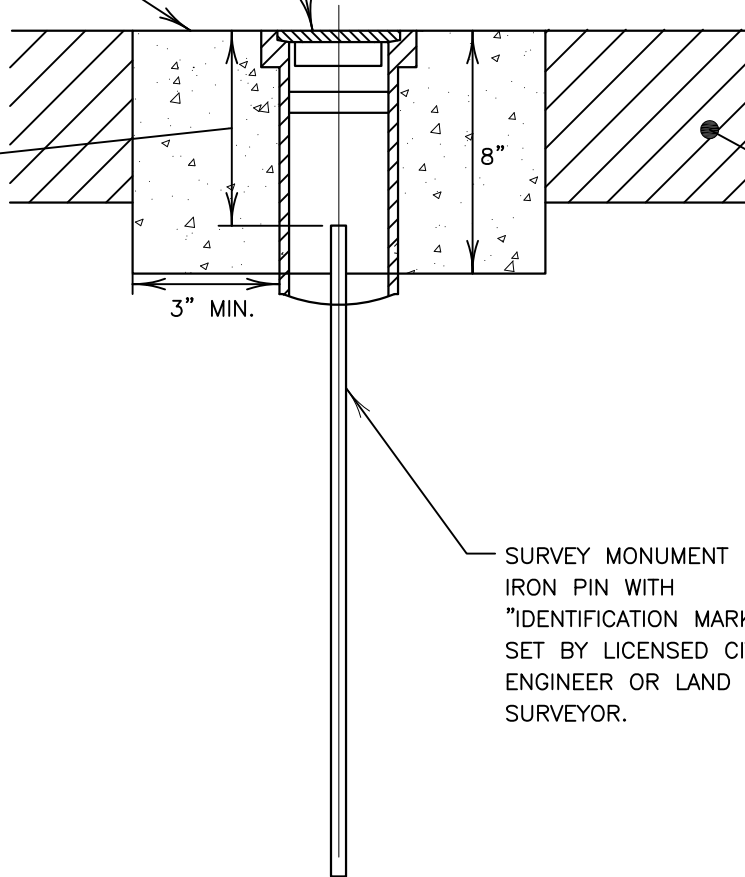

EXISTING
STRUCTURAL SECTION

SURVEY MONUMENT
IRON PIN WITH
"IDENTIFICATION MARKS"
SET BY LICENSED CIVIL
ENGINEER OR LAND
SURVEYOR.

NO.	REVISION	DATE	BY
DRAWN BY: BH, NR			
CHECKED BY: CD			
SCALE: NONE			
DATE: 03/2015			

STANDARD MONUMENT

CITY OF RIO VISTA
DEPARTMENT OF PUBLIC WORKS

APPROVED BY: CECIL DILLON
CITY ENGINEER
RCE 25835
DECEMBER 2015
DATE

STANDARD PLAN NO. **231**

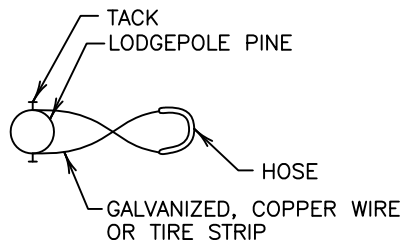

TREE TIE DETAIL

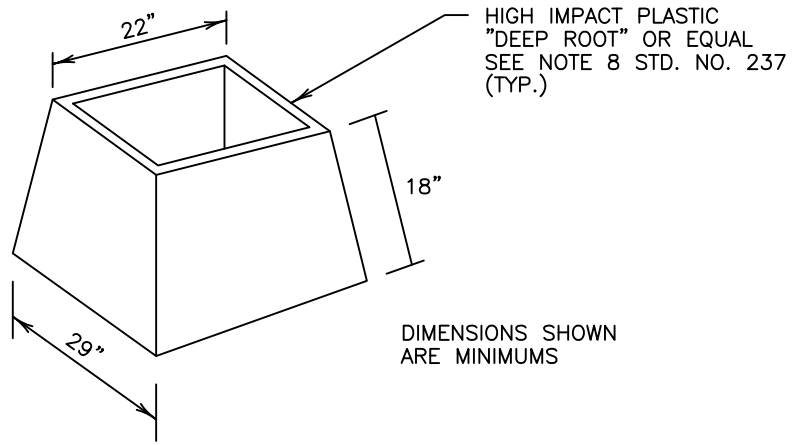
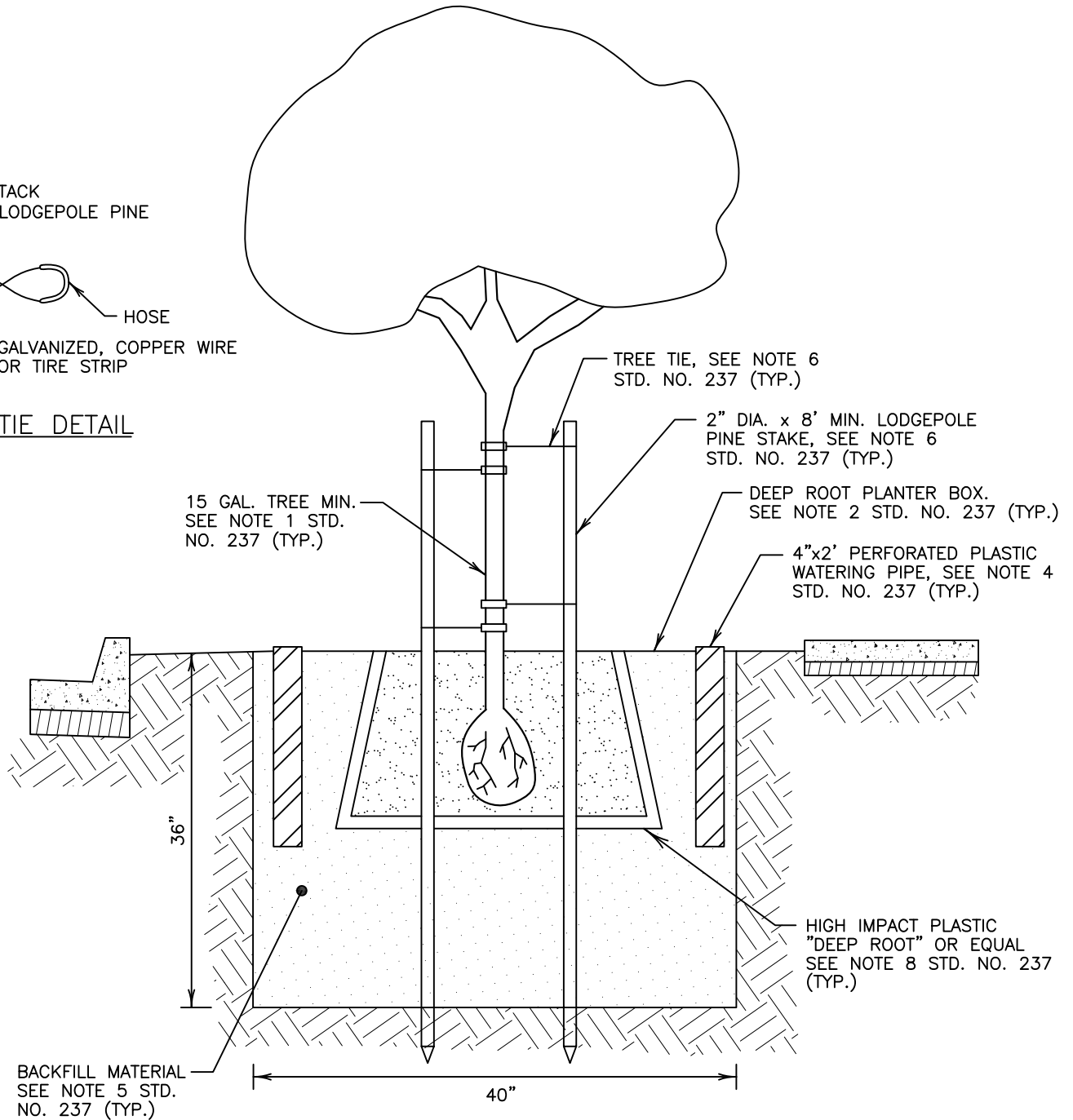

NO.	REVISION	DATE	BY
DRAWN BY: BH, NR			
CHECKED BY: CD			
SCALE: NONE			
DATE: 03/2015			

TREE PLANTING

CITY OF RIO VISTA
 DEPARTMENT OF PUBLIC WORKS

APPROVED BY: **CECIL DILLON**
 CITY ENGINEER
 RCF 25835

DECEMBER 2015
 DATE

STANDARD PLAN NO. **232**

GENERAL NOTES:

1. TREES SHALL BE A SIZE NOT LESS THAN 8 FT. IN HEIGHT NOR LESS THAN 1 INCH CALIPER. A TREE MAY BE REJECTED IF IT IS NOT OF A SHAPE OR CONDITION ACCEPTABLE TO THE CITY OF RIO VISTA
2. THE TREE SHALL BE PLANTED IN DEEP ROOT PLANTER BOX. THE PLANTER BOX MUST BE A MINIMUM OF 22 INCHES AT THE TOP, 29 INCHES AT THE BOTTOM AND 18 INCHES DEEP.
3. THE TREE SHALL BE PLANTED IN A HOLE 40 INCHES SQUARE BY 36 INCHES DEEP.
4. INSTALL TWO 24" DEEP WATERING PERFORATED PLASTIC PIPES AS SHOWN. FILL PIPES WITH 3/4 INCH CLEAN DRAIN ROCK.
5. TREES SHALL BE PLANTED IN A MIXTURE OF 1/2 NATIVE SOIL AND 1/2 LEAF MOLD OR REDWOOD MULCH.
6. TREES SHALL BE STAKED WITH TWO 2 INCH BY 8 FT. MINIMUM LODGE POLE PINE STAKES OR EQUAL. STAKES SHALL BE COATED WITH GREEN PRESERVATIVE STAIN. TREES SHALL BE TIED WITH "GRO STRAIT" TREE TIES, OR SIMILAR.
7. TREES SHALL BE PLANTED A MINIMUM OF 20 FT. APART TO A MAXIMUM OF 50 FT. APART DEPENDING ON THE TYPE OF THE TREE. TREES SHALL BE PLANTED A MINIMUM OF 20 FT. FROM CURB RETURNS, 15 FT. FROM STREET LIGHTS AND 6 FT. FROM DRIVEWAYS, SEWER LATERALS AND WATER SERVICES OR AS OTHERWISE APPROVED BY THE CITY OF RIO VISTA.
8. DEEP ROOT PLANTER SHALL BE FABRICATED FROM A HIGH DENSITY AND HIGH IMPACT PLASTIC SUCH AS POLYVINYL CHLORIDE, ABS OR POLYETHYLENE AND HAVE A MINIMUM THICKNESS OF 0.06 INCH. THE PLASTIC SHALL HAVE 1/2 INCH HIGH RAISED VERTICAL RIBS ON THE INNER SURFACE SPACED NOT MORE THAN SIX (6) INCHES APART.

NO.	REVISION	DATE	BY	TREE PLANTING NOTES	APPROVED BY:	DECEMBER
					CECIL DILLON	2015
DRAWN BY: BH, NR				CITY OF RIO VISTA DEPARTMENT OF PUBLIC WORKS	CITY ENGINEER	DATE
CHECKED BY: CD					RCE 25835	
SCALE: NONE					STANDARD	233
DATE: 03/2015					PLAN NO.	

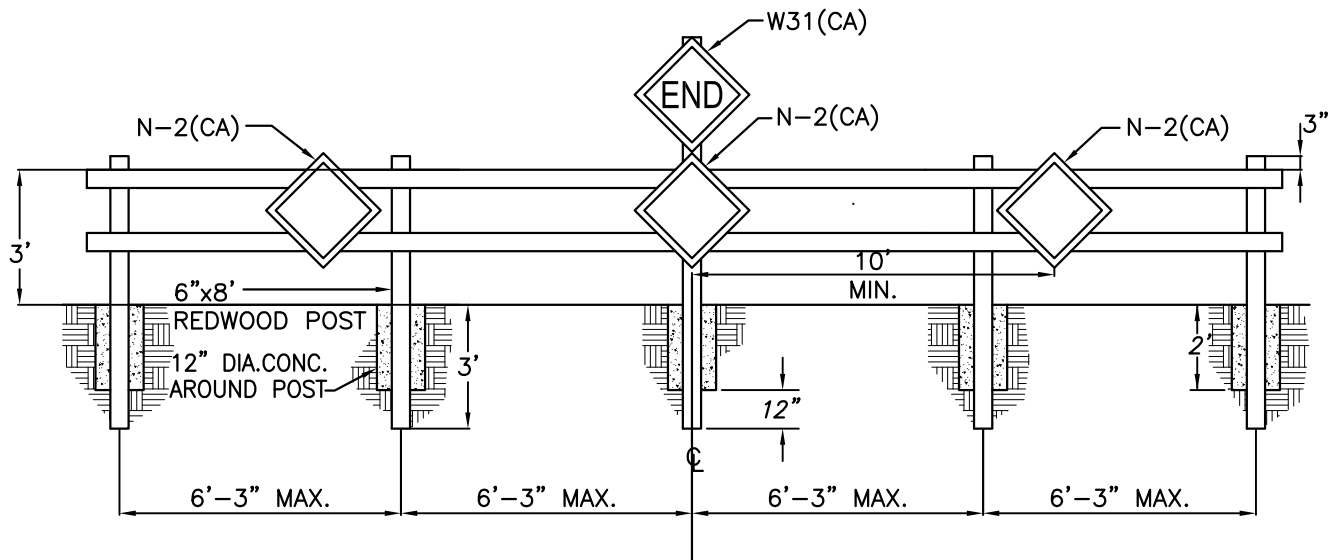

END OF ROAD WAY

NOTES:

1. INSTALL 6"x8' REDWOOD OR PRESSURE TREATED DOUGLAS FIR POSTS NO MORE THAN 6'-3" APART AND NO LESS THAN 3' INTO THE GROUND.
2. POUR A 12" DIAMETER CONCRETE COLLAR AROUND EACH POST TO A DEPTH OF 12" ABOVE THE POST BASE.
3. CROSSBARS SHALL BE 2"x6" DOUGLAS FIR SELECT, WITH A MINIMUM LENGTH OF 16'.
4. ATTACH CROSSBAR WITH 1/2"x8" GALVANIZED BOLTS. 2 MINIMUM AT EACH POST. USE 4 BOLTS AT SPLICE.
5. PAINT WITH NO LESS THAN 2 COATS OF OUTSIDE WHITE HI-GLOSS ENAMEL PAINT.
6. INSTALL (3) - 18" (TYPE N-2(CA)) REFLECTORS. INSTALL (1) - W31(CA) AS SHOWN.
7. BARRICADE TO EXTEND TO BACK OF SIDEWALK WHEN SIDEWALK PRESENT.

NO.	REVISION DATE	BY	STANDARD BARRICADE	APPROVED BY:	DECEMBER
				CECIL DILLON	2015
DRAWN BY: BH, NR			CITY OF RIO VISTA DEPARTMENT OF PUBLIC WORKS	CITY ENGINEER	DATE
CHECKED BY: CD				RCE 25835	
SCALE: NONE				STANDARD	234
DATE: 03/2015				PLAN NO.	

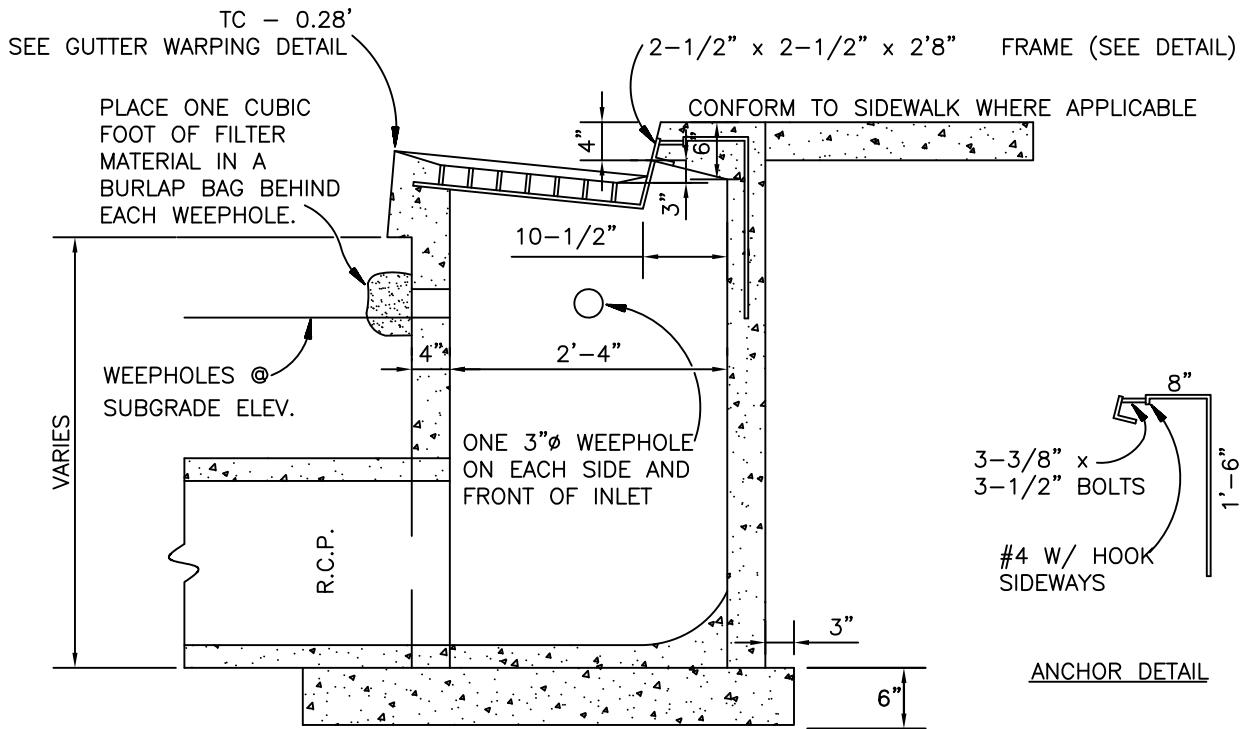
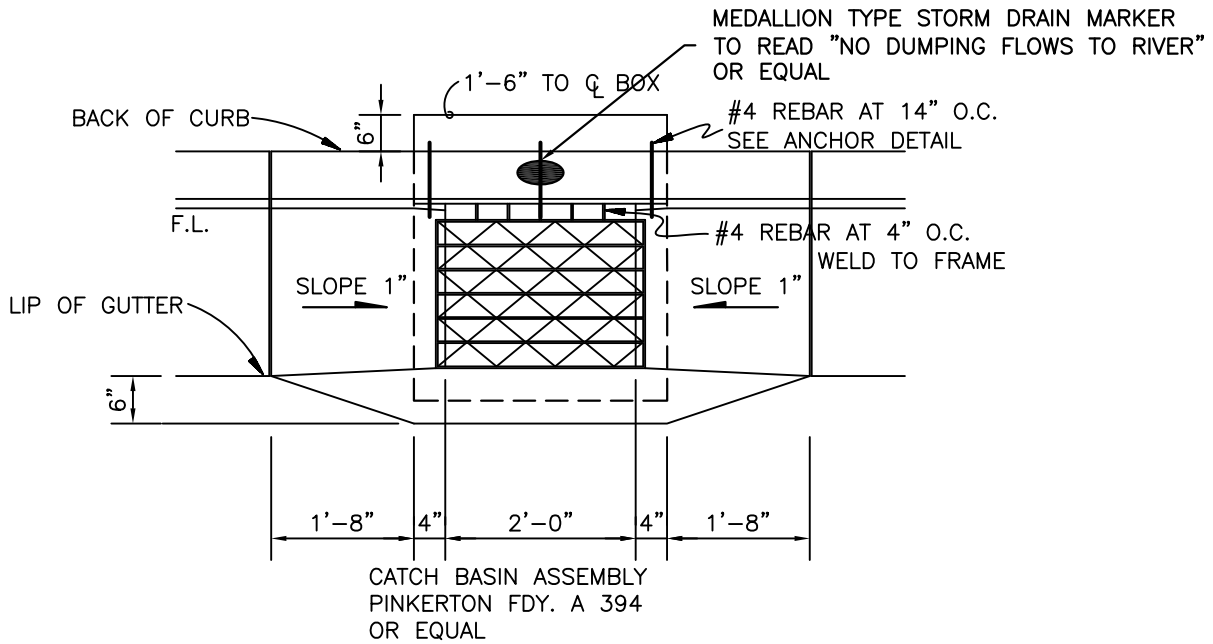

CATCH BASIN DETAIL

NOT TO SCALE

NO.	REVISION	DATE	BY
DRAWN BY: BH, NR			
CHECKED BY: CD			
SCALE: NONE			
DATE: 03/2015			

CATCH BASIN		APPROVED BY: CECIL DILLON CITY ENGINEER RCF 25835	DECEMBER 2015 DATE
CITY OF RIO VISTA DEPARTMENT OF PUBLIC WORKS		STANDARD PLAN NO. 301	

APPROVED BY: CECIL DILLON CITY ENGINEER RCF 25835	DECEMBER 2015 DATE
STANDARD PLAN NO. 301	

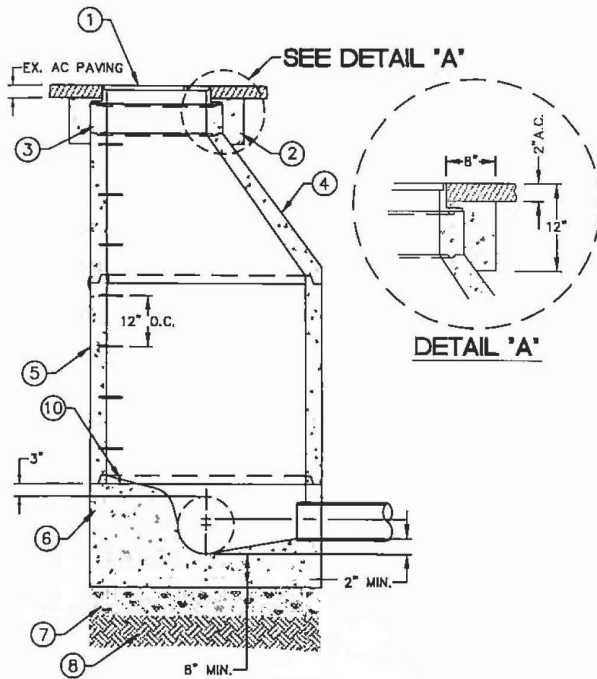

1. FRAME COVER, D & L SUPPLY 1024 MARKED "STORM DRAIN" WITH PICK HOLE.
2. CLASS "A" CONCRETE COLLAR WITH 2" AC.
3. STANDARD TWENTY FOUR (24) INCH DIAMETER MANHOLE GRADE RINGS, THREE (3) INCH MINIMUM EIGHTEEN (18) INCH MAXIMUM NECK HEIGHT FROM CONE TO FINISH GRADE.
4. STANDARD FORTY EIGHT (48) INCH ECCENTRIC MANHOLE REDUCER CONE. COPOLYMER POLYPROPYLENE STEPS REQUIRED @ 12" O.C FOR MANHOLES DEEPER THAN FIVE (5) FEET.
5. STANDARD FORTY EIGHT (48) INCH DIAMETER MANHOLE BARREL SECTION, CONFORMING TO ASTM C478-LATEST REVISION, WITH FOUR (4) INCH MINIMUM WALL THICKNESS. COPOLYMER POLYPROPYLENE STEPS REQUIRED FOR MANHOLES MORE THAN FIVE (5) FEET.
6. CLASS "A", CAST -IN-PLACE OR PRECAST CONCRETE BASE.
7. SIX (6) INCHES MINIMUM 3/4 INCH CRUSHED ROCK PER ASTM D448 #67
8. UNDISTURBED SOIL.
9. FOUR (4) INCHES PER FOOT MINIMUM SLOPE.

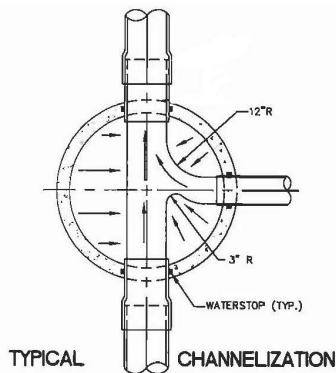

NOTES:

- A. COUNTRY OF ORIGIN SHALL BE CLEARLY AND PERMANENTLY SHOWN ON TOP SURFACE OF THE FRAME AND COVER IN ACCORDANCE WITH THE TRADE AND TARIFF ACT OF 1984.
- B. DATE OF MANUFACTURE SHALL BE CLEARLY AND PERMANENTLY INDICATED ON THE COVER AND TOP OF THE FRAME.
- C. SEATING SURFACE SHALL BE CLOSELY MACHINED TO NOMINAL DIMENSIONS WITH TOLERANCES NOT TO EXCEED $\pm 1/64$ INCH.
- D. THE WEIGHT OF THE FRAME SHALL BE 140LBS., ± 10 LBS.
- E. THE WEIGHT OF THE COVER SHALL BE 130LBS., ± 5 LBS.
- F. THE STORM DRAIN MANHOLE SHALL NOT BE USED ON STORM DRAIN CONDUIT GREATER THAN 36 INCHES IN DIAMETER.

NO.	REVISION	DATE	BY
DRAWN BY: BH, NR			
CHECKED BY: CD			
SCALE: NONE			
DATE: 03/2015			

STORM DRAIN MANHOLE

CITY OF RIO VISTA
DEPARTMENT OF PUBLIC WORKS

APPROVED BY: **CECIL DILLON** DECEMBER 2015
CITY ENGINEER
RCF 25835 DATE

STANDARD PLAN NO. 302

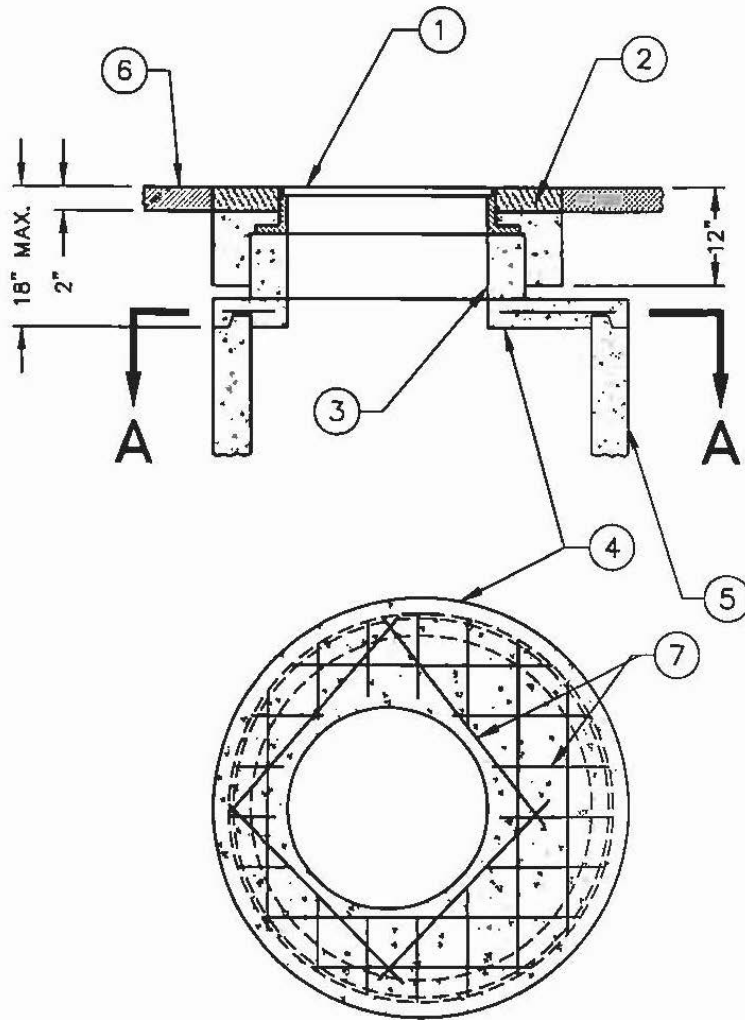

SECTION A-A

1. FRAME AND COVER, SEE STANDARD DETAIL #302.
2. CLASS "A" CONCRETE COLLAR WITH 2" A.C. COLLAR, SEE STANDARD DETAIL #302.
3. GRADE RING(S), 2-FOOT INSIDE DIAMETER; 18" MAXIMUM HEIGHT.
4. USE FLAT SLAB TOP IF DEPTH DOES NOT PERMIT USE OF TAPERED CONE. DESIGN SHALL MEET H-20 LOADING REQUIREMENTS AND BE TESTED IN ACCORDANCE WITH ASTM C-497.
5. STANDARD BARREL.
6. STREET STRUCTURAL SECTION.
7. REINFORCING BARS, TYPICAL. DESIGN BY PROJECT ENGINEER.

NO.	REVISION	DATE	BY
DRAWN BY: BH, NR			
CHECKED BY: CD			
SCALE: NONE			
DATE: 03/2015			

FLAT SLAB MANHOLE TOP

CITY OF RIO VISTA
DEPARTMENT OF PUBLIC WORKS

APPROVED BY: **CECIL DILLON** DECEMBER 2015
CITY ENGINEER
RCE 25835 DATE

STANDARD PLAN NO. **303**

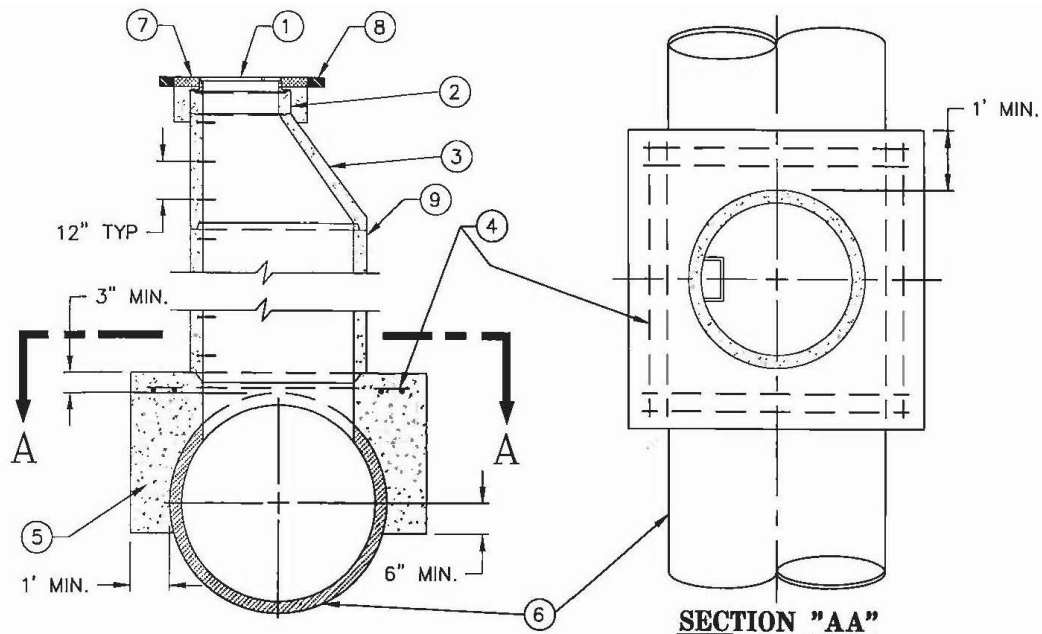

1. FRAME AND COVER, SEE DETAIL # 302
2. GRADE RINGS, 24 INCH INSIDE DIAMETER; 3 INCH MIN., 18 INCH MAX. FROM CONE TO FINISH GRADE.
3. STANDARD 48 INCH ECCENTRIC MANHOLE REDUCER CONE SHOWN WITH COPOLYMER POLYPROPYLENE STEPS.
4. TWO #5 REBAR EACH WAY.
5. CLASS "A" CONCRETE.
6. EXISTING STORM DRAIN PIPE.
7. CLASS "A" CONCRETE COLLAR WITH 2" AC.
8. STREET STRUCTURAL SECTION.
9. STANDARD FORTY EIGHT (48) INCH DIAMETER MANHOLE SECTION, CONFORMING TO ASTM C478 LATEST REVISION WITH FOUR (4) INCH MINIMUM WALL THICKNESS. COPOLYMER POLYPROPYLENE STEPS REQUIRED @ 12" O.C. FOR MANHOLES MORE THAN FIVE (5) FEET DEEP.

NOTE: SADDLE MANHOLES SHALL ONLY BE ALLOWED ON STORM DRAIN PIPE GREATER THAN 36 INCHES IN DIAMETER, PROVIDED THAT NO JUNCTION EXISTS WITH ANY OTHER STORM DRAIN CONDUIT AT THE MANHOLE.

NO.	REVISION	DATE	BY
DRAWN BY: BH, NR			
CHECKED BY: CD			
SCALE: NONE			
DATE: 03/2015			

SADDLE MANHOLE

CITY OF RIO VISTA
DEPARTMENT OF PUBLIC WORKS

APPROVED BY: **CECIL DILLON** DECEMBER 2015
CITY ENGINEER DATE
RCF 25835

STANDARD PLAN NO. **304**

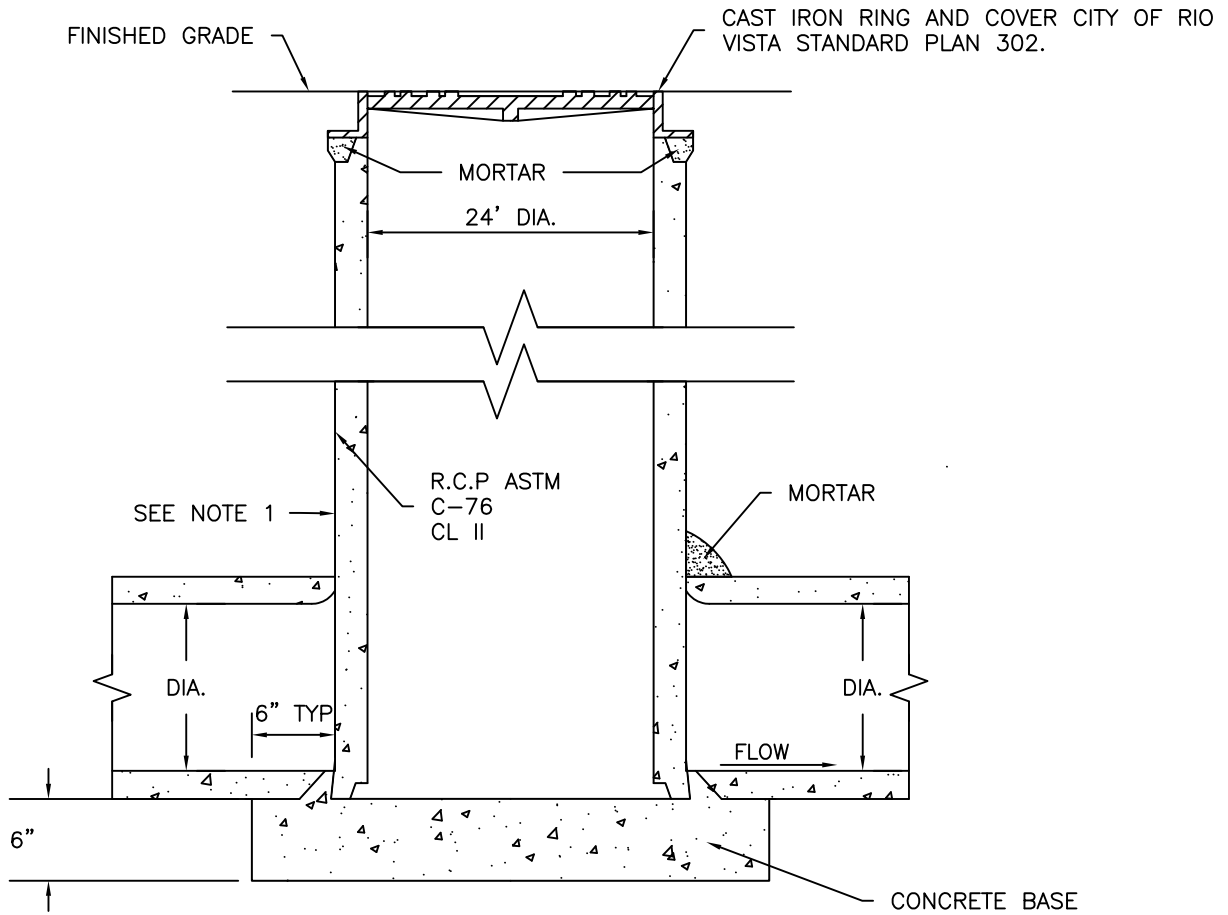

NOTES:

1. BACKFILL AROUND RISER SHALL BE A MINIMUM OF 95% R.C. (90% IN LANDSCAPE AREAS).
2. CONCRETE:
 - A. 2500 PSI @28 DAYS
 4. 4' SLUMP MAXIMUM
 5. CLASS "B" CONCRETE PER SECTION 90 OF STANDARD SPECIFICATIONS. 1-1/2" MAX. AGG.
3. FOR DEPTH OVER 60", USE 48" MANHOLE, STANDARD PLAN 302.
4. FOR TRENCH BACKFILL REQUIREMENTS, SEE STANDARD PLAN 101.

NO.	REVISION	DATE	BY
DRAWN BY: BH, NR			
CHECKED BY: CD			
SCALE: NONE			
DATE: 03/2015			

24" MONITORING STRUCTURE

CITY OF RIO VISTA
DEPARTMENT OF PUBLIC WORKS

APPROVED BY: CECIL DILLON
CITY ENGINEER
RCF 25835
DECEMBER 2015
DATE

STANDARD PLAN NO. 305

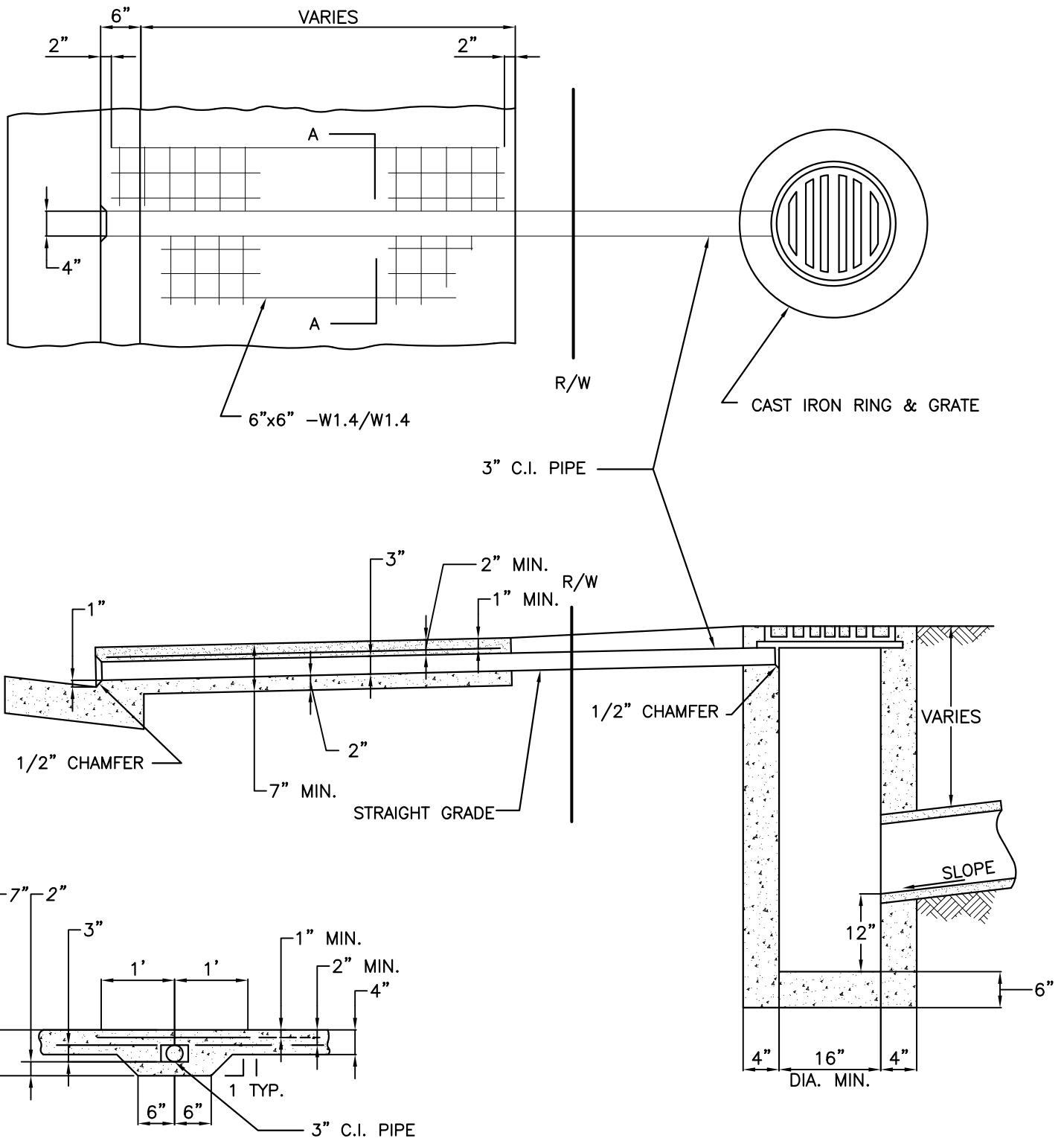

SECTION "A"

NOTES:

- 1. SEE STD. PLAN 207 & 209 FOR CURB GUTTER AND SIDEWALK DETAILS

NO.	REVISION	DATE	BY

DRAWN BY: BH, NR
 CHECKED BY: CD
 SCALE: NONE
 DATE: 03/2015

**YARD DRAIN
THROUGH CURB**

CITY OF RIO VISTA
DEPARTMENT OF PUBLIC WORKS

APPROVED BY: **CECIL DILLON** DECEMBER 2015
 CITY ENGINEER
 RCF 25835 DATE

STANDARD PLAN NO. 306

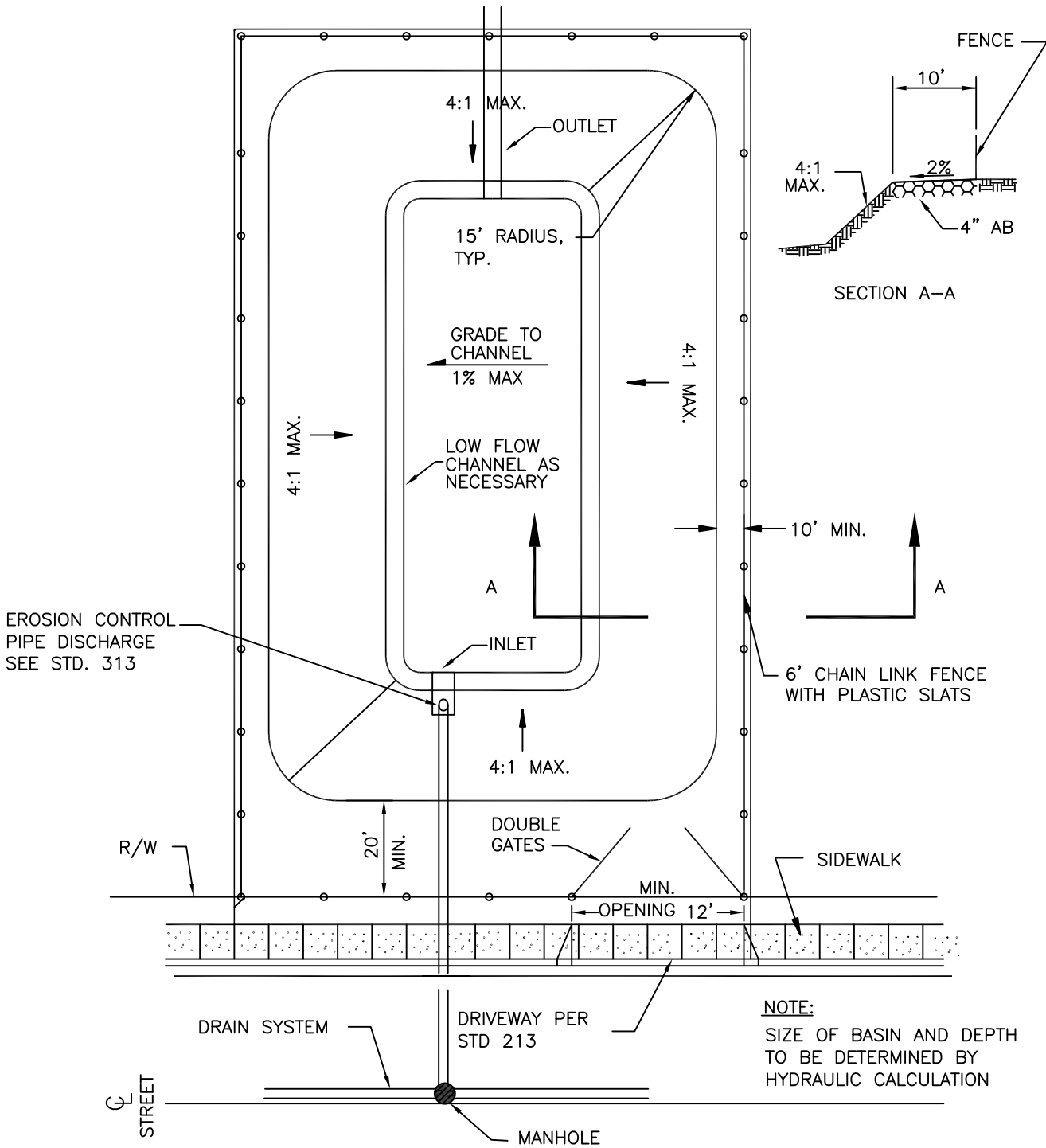

NOTE:
 SIZE OF BASIN AND DEPTH
 TO BE DETERMINED BY
 HYDRAULIC CALCULATION

- NOTES:**
1. 8:1 SIDE SLOPES ARE REQUIRED FOR DETENTION BASINS THAT DOUBLE AS PARK FACILITIES
 2. GRAVITY DISCHARGE IS DESIRABLE AND THE DESIGN MUST BE SUBMITTED FOR APPROVAL
 3. PUMP STATIONS ARE ALLOWABLE ONLY WITH APPROVAL OF THE CITY ENGINEER

NO.	REVISION	DATE	BY

DRAWN BY: BH, NR
 CHECKED BY: CD
 SCALE: NONE
 DATE: 03/2015

**STANDARD COMMUNITY
 DETENTION BASIN**

**CITY OF RIO VISTA
 DEPARTMENT OF PUBLIC WORKS**

APPROVED BY: **CECIL DILLON** DECEMBER 2015
 CITY ENGINEER DATE
 RCF 25835

STANDARD PLAN NO. 307

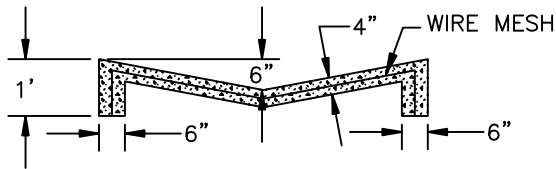

SECTION A-A

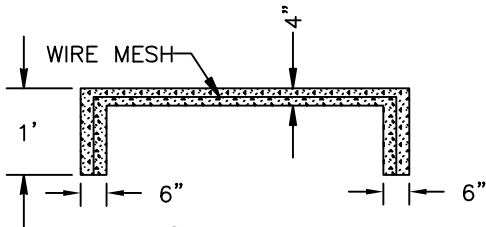

SECTION B-B

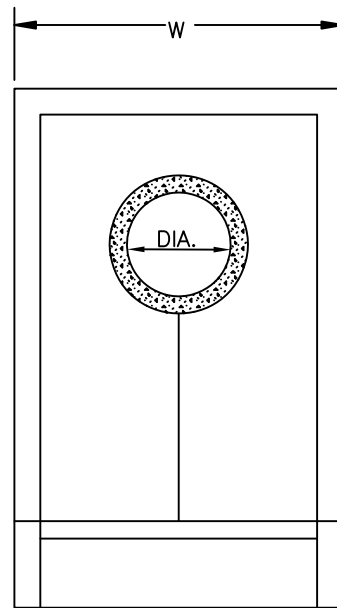

FRONT VIEW

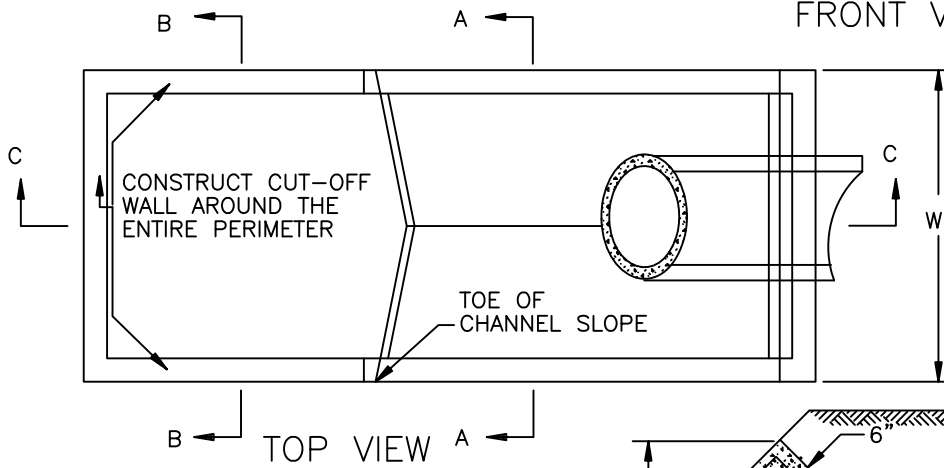

TOP VIEW

W = 6'-0" MINIMUM
W = 2 X PIPE DIA. (3' TO 6')

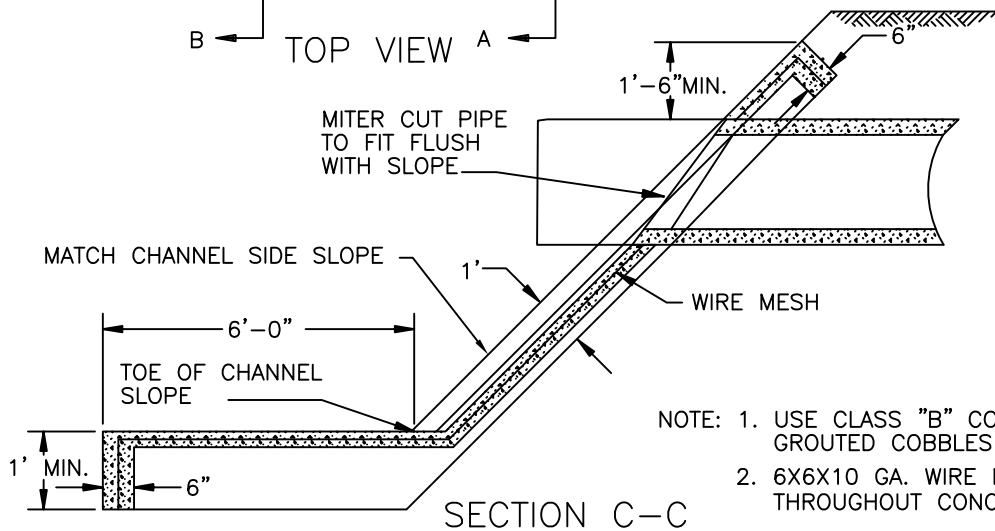

SECTION C-C

- NOTE: 1. USE CLASS "B" CONCRETE OR GROUTED COBBLES AS SPECIFIED.
2. 6X6X10 GA. WIRE MESH THROUGHOUT CONCRETE

NO.	REVISION	DATE	BY

DRAWN BY: BH, NR
CHECKED BY: CD
SCALE: NONE
DATE: 03/2015

**EROSION CONTROL
PIPE DISCHARGE**

CITY OF RIO VISTA
DEPARTMENT OF PUBLIC WORKS

APPROVED BY: **CECIL DILLON** DECEMBER 2015
CITY ENGINEER
RCF 25835 DATE

**STANDARD
PLAN NO. 308**

DURATION - HOURS

1 2 3 4 5 6 7

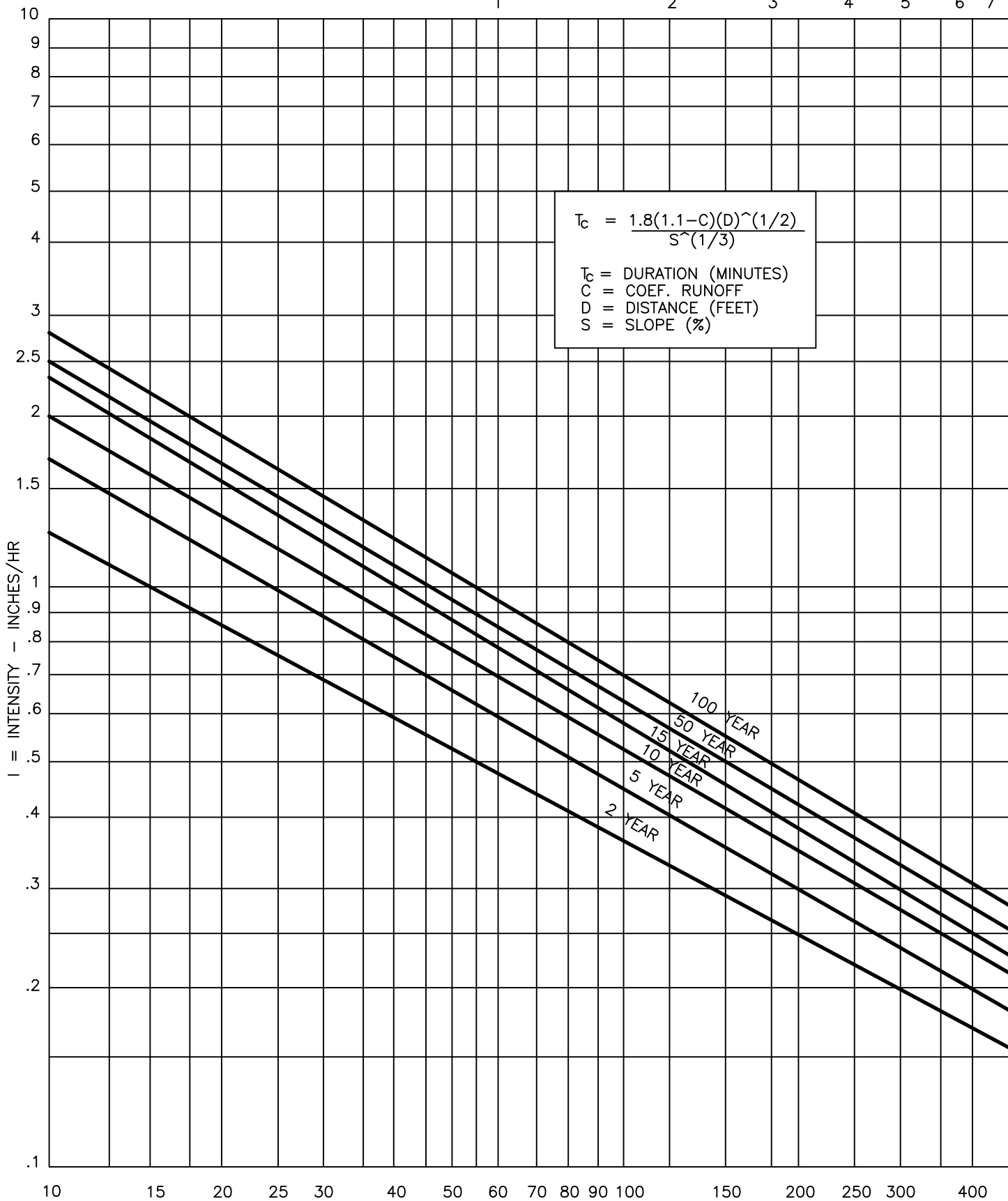

$$T_c = \frac{1.8(1.1-C)(D)^{1/2}}{S^{1/3}}$$

T_c = DURATION (MINUTES)
 C = COEF. RUNOFF
 D = DISTANCE (FEET)
 S = SLOPE (%)

MEAN ANNUAL PRECIPITATION 17 INCHES T_c = DURATION - MINUTES

NO.	REVISION DATE	BY	RAINFALL - INTENSITY DURATION - FREQUENCY	APPROVED BY:	DECEMBER
				CECIL DILLON	2015
DRAWN BY: BH, NR			CITY OF RIO VISTA DEPARTMENT OF PUBLIC WORKS	CITY ENGINEER	DATE
CHECKED BY: CD				RCE 25835	
SCALE: NONE				STANDARD	309
DATE: 03/2015				PLAN NO.	

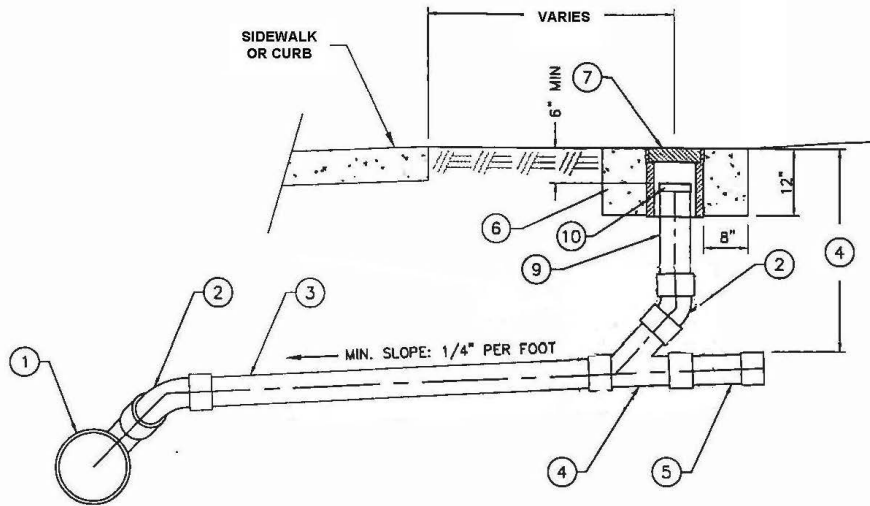

1. SEWER MAIN WITH SEWER SERVICE WYE AT 30-45 DEGREES.
2. WYE BRANCH WITH 1/8 BENDS OR 4" ABS LONGSWEEP COMBO.
3. SEWER SERVICE SHALL BE CONSTRUCTED WITH A STRAIGHT GRADE AND ALIGNMENT FROM THE MAIN TO THE RIGHT-OF-WAY UNLESS OTHERWISE APPROVED BY THE CITY ENGINEER. SEWER SERVICES SHALL BE CONSTRUCTED OF DUCTILE IRON PIPE (CLASS 52) OR POLYVINYL CHLORIDE PIPE (SDR 26).
4. SEWER SERVICE SHALL HAVE A MINIMUM OF 36" OF COVER FROM FINISHED GRADE AT RIGHT-OF-WAY. SEWER SERVICES THAT HAVE LESS THAN 36" OF COVER, SHALL REQUIRE SPECIAL APPROVAL BY THE CITY ENGINEER.
5. SERVICE TO BUILDING. IF NO BUILDING, STUB LATERAL 12" BEYOND RIGHT-OF-WAY WITH WATER TIGHT CAP.
6. CLASS "A" CONCRETE EXCEPT IN RESIDENTIAL PLANTER OR LAWN AREAS.
7. CLEANOUT BOX SHALL BE A CHRISTY G5 BOX WITH CAST IRON LID WHEN SUBJECT TO TRAFFIC LOADS. USE CRISTY F08 BOX IN RESIDENTIAL LAWN AND PLANTER AREAS. ALL LIDS SHALL READ "SEWER C.O."
8. CURB, GUTTER, AND SIDEWALK WITH A 2" X 2" LETTER "S" STAMPED, CHISELED, ETC. ON TOP OF CURB LOCATED DIRECTLY ABOVE WHERE SEWER SERVICE CROSSES THE GUTTER FLOWLINE. METHOD TO BE APPROVED BY THE CITY ENGINEER.
9. RISER SAME MATERIAL AS SEWER SERVICE.
10. RUBBER END CAP W/STAINLESS STEEL SHEAR BAND.

NOTES:

- A. SEWER SERVICES SHALL BE RUN TO MANHOLES WHENEVER POSSIBLE.
- B. SEWER CLEANOUTS SHALL LIE WITHIN CITY R/W OR A DEDICATED PUBLIC EASEMENT IN ALL CASES.

NO.	REVISION	DATE	BY
DRAWN BY: BH, NR			
CHECKED BY: CD			
SCALE: NONE			
DATE: 03/2015			

**RESIDENTIAL SEWER SERVICE
WITH CLEANOUT**

CITY OF RIO VISTA
DEPARTMENT OF PUBLIC WORKS

APPROVED BY:	DECEMBER
CECIL DILLON	2015
CITY ENGINEER	DATE
RCE 25835	
STANDARD	401
PLAN NO.	

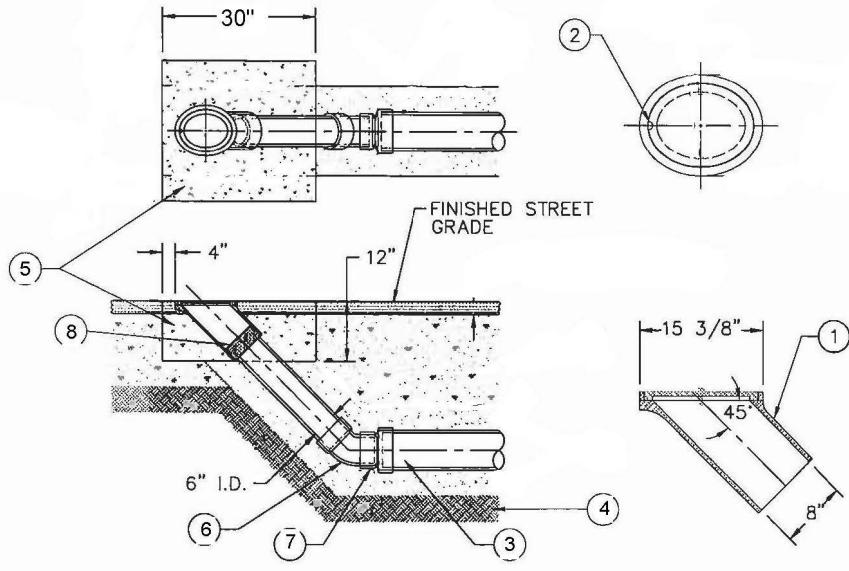

1. CAST IRON FLUSHING INLET, FRAME AND COVER, SOUTHBAY FOUNDRY 1247 OR APPROVED EQUAL W/C.O.
2. 1/2" BY 1" PICK HOLE.
3. PROPOSED SEWER MAIN.
4. UNDISTURBED SOIL.
5. CLASS "A" CONCRETE WITH 2" A.C.
6. 1/8 BEND.
7. REDUCE (IF REQUIRED)
8. RUBBER END CAP WITH STAINLESS STEEL SHEAR BAND.

NO.	REVISION	DATE	BY
DRAWN BY: BH, NR			
CHECKED BY: CD			
SCALE: NONE			
DATE: 03/2015			

SEWER FLUSHING INLET

CITY OF RIO VISTA
DEPARTMENT OF PUBLIC WORKS

APPROVED BY:	DECEMBER
CECIL DILLON	2015
CITY ENGINEER	DATE
RCE 25835	
STANDARD PLAN NO.	402

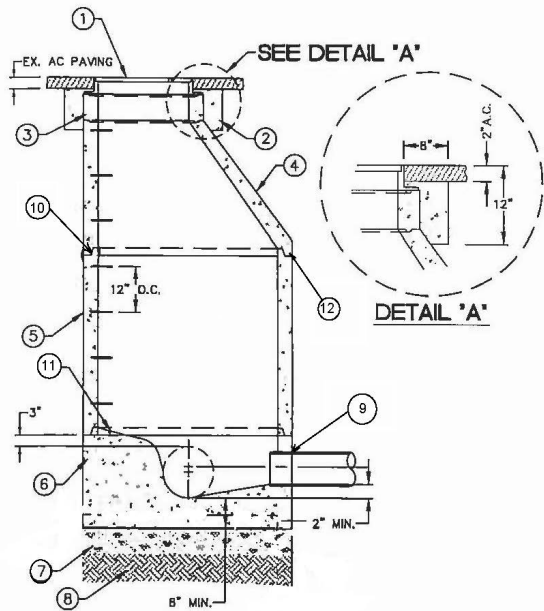

1. FRAME AND COVER, D&L SUPPLY 1024 MARKED "SANITARY SEWER" WITH PICK HOLE.
2. CLASS "A" CONCRETE COLLAR WITH 2" AC.
3. STANDARD TWENTY FOUR (24) INCH DIAMETER MANHOLE GRADE RINGS THREE (3) INCH MINIMUM, EIGHTEEN (18) INCH MAXIMUM NECK HEIGHT FROM CONE TO FINISH GRADE.
4. STANDARD FORTY EIGHT (48) INCH ECCENTRIC MANHOLE REDUCER CONE. COPOLYMER POLYPROPYLENE STEPS REQUIRED FOR MANHOLES DEEPER THAN FIVE (5) FEET.
5. STANDARD FORTY EIGHT (48) INCH DIAMETER MANHOLE BARREL SECTION, CONFORMING TO ASTM C478—LATEST REVISION WITH FOUR (4) INCH MINIMUM WALL THICKNESS. COPOLYMER POLYPROPYLENE STEPS REQUIRED FOR MANHOLES MORE THAN FIVE (5) FEET DEEP.
6. CLASS "A" CAST-IN-PLACE OR PRECAST CONCRETE BASE.
7. SIX (6) INCHES MINIMUM, 3/4 INCH CRUSHED ROCK PER ASTM D448 #67.
8. UNDISTURBED SOIL.
9. CONNECTIONS TO MANHOLE SHALL BE MADE BY UTILIZING MANHOLE ADAPTERS OR ELASTOMERIC SEAL RINGS EMBEDDED IN THE CONCRETE.
10. BARREL SECTION JOINTS SHALL BE SEALED BY PRE-FORMED PLASTIC SEALING GASKETS THAT CONFORM TO FEDERAL SPECIFICATION SS-S-00210.
11. FOUR (4) INCHES PER FOOT MINIMUM SLOPE.
12. ALL JOINTS SHALL BE MORTARED OUTSIDE OF MANHOLE

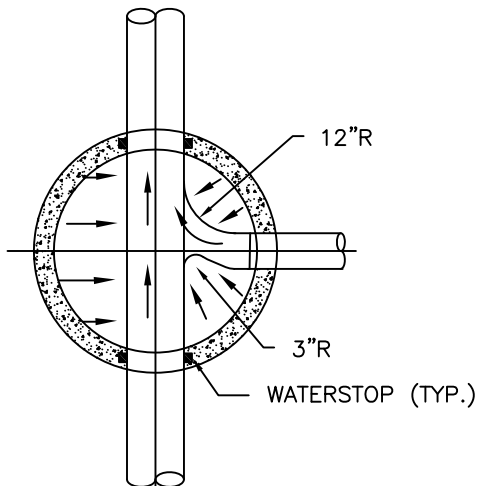

NOTES:

- A. COUNTRY OF ORGIN SHALL BE CLEARLY AND PERMANENTLY SHOWN ON TOP SURFACE OF THE FRAME AND COVER IN ACCORDANCE WITH THE TRADE AND TARIFF ACT OF 1984
- B. DATE OF MANUFACTURE SHALL BE CLEARLY AND PERMANENTLY INDICATED ON THE COVER AND THE TOP OF THE FRAME.
- C. SEATING SURFACE SHALL BE CLOSELY MACHINED TO NOMINAL DIMENSIONS WITH TOLERANCES NOT TO EXCEED +/- 1/64 INCH.
- D. THE WIEGHT OF THE FRAME SHALL BE 140LBS., +/- 10LBS.
- E. THE WIEGHT OF THE COVER SHALL BE 130LBS., +/- 5LBS.
- F. VACUUM TEST REQUIRED.
- G. SANITARY "SEWER" SHALL BE STAMPED CLEARLY AND PERMANENTLY ON THE COVER.

NO.	REVISION	DATE	BY
DRAWN BY: BH, NR			
CHECKED BY: CD			
SCALE: NONE			
DATE: 03/2015			

SEWER MANHOLE

CITY OF RIO VISTA
DEPARTMENT OF PUBLIC WORKS

APPROVED BY: DECEMBER
CECIL DILLON 2015
CITY ENGINEER DATE
RCF 25835

STANDARD PLAN NO. 403

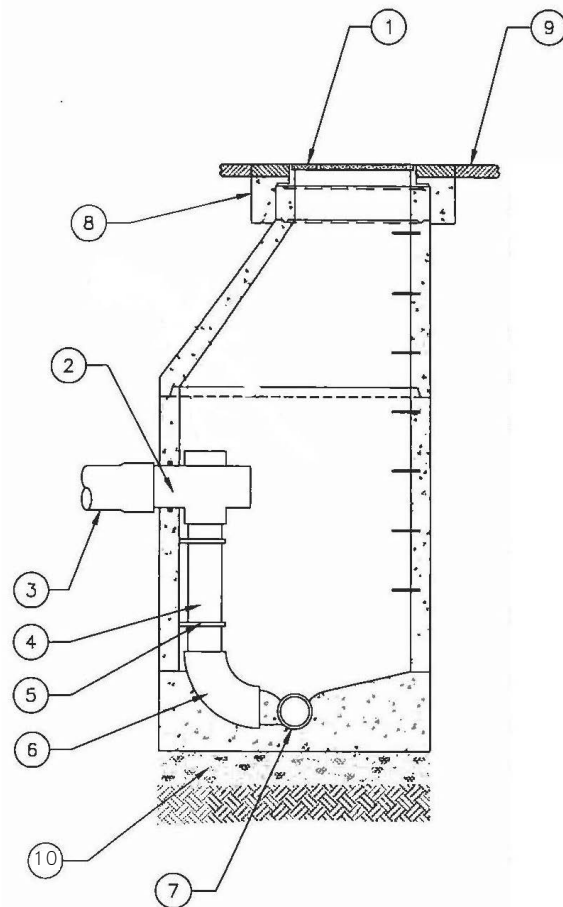

1. FRAME AND COVER SEE DETAIL 403
2. SCHEDULE 40, PVC CROSS SOLVENT WELD (TYPICAL ALL DROP FITTINGS). CUT OFF INBOARD LET OF TEE IF NECESSARY.
3. ADAPT TO MAIN.
4. DROP PIPE.
5. 3/32" BY 2" TYPE 316 STAINLESS STEEL STRAP ANCHORED TO MANHOLE WALL WITH 5/8", STAINLESS STEEL ANCHOR BOLTS. 3' MAXIMUM SPACING 2 STRAPS MIN. PER DROP.
6. PVC ELBOW. CHIP OUT CHANNEL AS SHOWN. FILL VOIDS WITH EPOXY. XYPEX OR APPROVED EQUAL.
7. SEWER MAIN (EXISTING OR TO BE CONSTRUCTED)
8. CLASS "A" CONCRETE COLLAR WITH 2" A.C.
9. STREET STRUCTURAL SECTION.
10. MINIMUM 6" OF 3/4" CRUSHED ROCK PER ASTM D448 #67 COMPACTED TO 95% RELATIVE COMPACTION.

NOTE:

A. INSIDE DROP CONNECTIONS SHALL BE ALLOWED ONLY UPON PRIOR APPROVAL OF THE CITY ENGINEER.

NO.	REVISION DATE	BY	SEWER MANHOLE WITH INSIDE DROP CONNECTION	APPROVED BY:	DECEMBER
				CECIL DILLON	2015
				CITY ENGINEER	DATE
DRAWN BY: BH, NR			CITY OF RIO VISTA DEPARTMENT OF PUBLIC WORKS	RCE 25835	
CHECKED BY: CD					
SCALE: NONE				STANDARD	404
DATE: 03/2015				PLAN NO.	

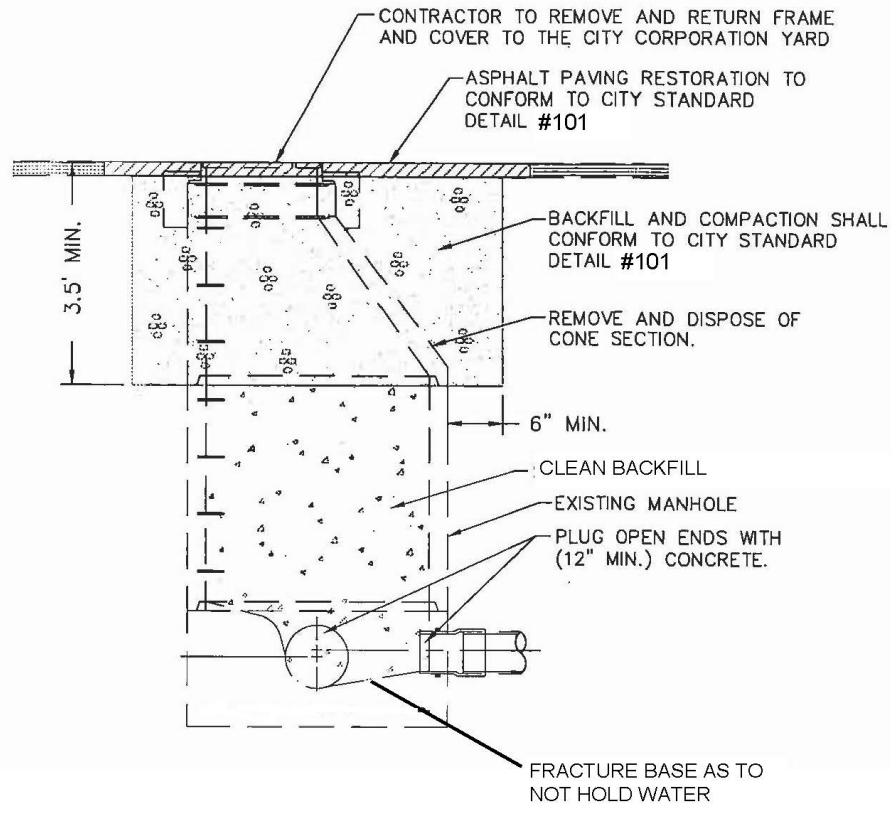

NOTE:

A. REMOVE CONE AND BARREL SECTION ON MANHOLES SHALLOWER THAN 5'.

NO.	REVISION	DATE	BY
DRAWN BY: BH, NR			
CHECKED BY: CD			
SCALE: NONE			
DATE: 03/2015			

**SEWER MANHOLE
ABANDONMENT**

CITY OF RIO VISTA
DEPARTMENT OF PUBLIC WORKS

APPROVED BY:	DECEMBER
CECIL DILLON	2015
CITY ENGINEER	DATE
RCE 25835	
STANDARD PLAN NO.	405

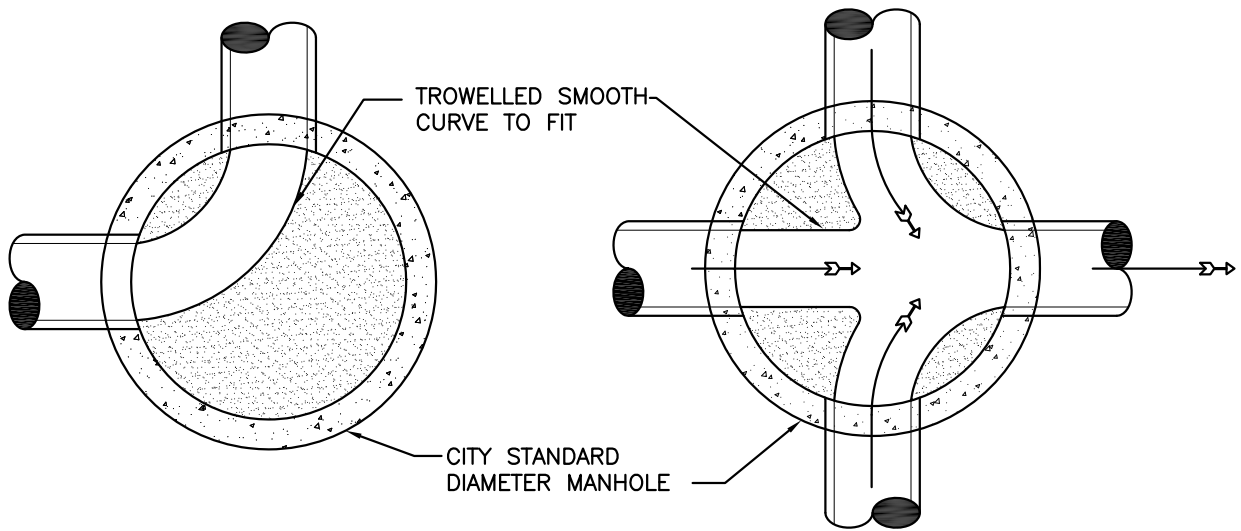

**TYPICAL M.H. AT
PIPELINE ANGLE**

**TYPICAL M.H. WITH
2 BRANCHES**

NOTE:

PRECAST BASES ARE
ACCEPTABLE.

LEGEND

 INDICATES SHELF

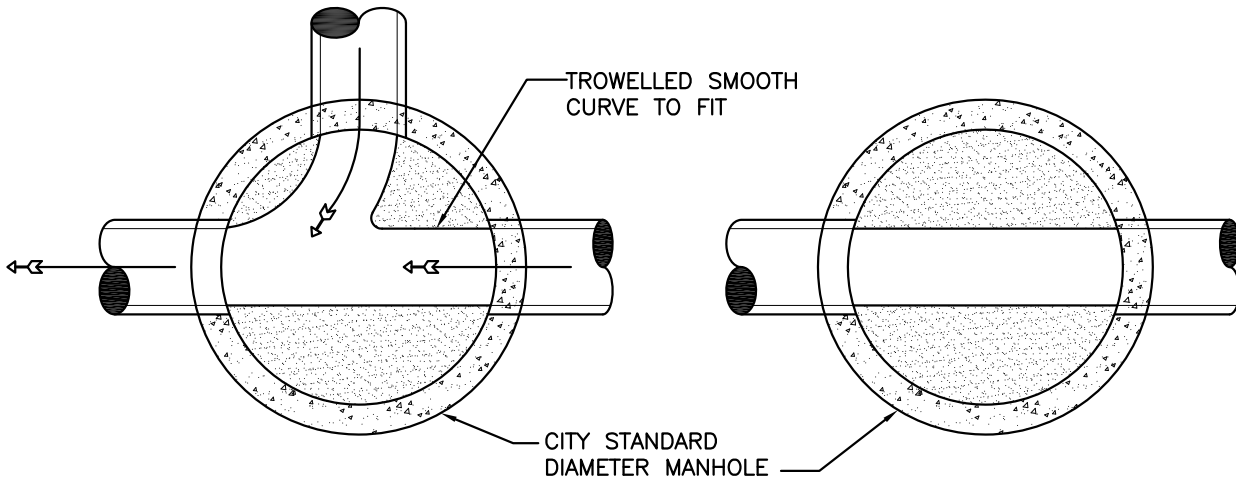

**TYPICAL M.H.
1 BRANCH**

**TYPICAL STRAIGHT
THROUGH M.H.**

NO.	REVISION	DATE	BY
DRAWN BY: BH, NR			
CHECKED BY: CD			
SCALE: NONE			
DATE: 03/2015			

**STANDARD MANHOLE
CHANNELIZATION**

**CITY OF RIO VISTA
DEPARTMENT OF PUBLIC WORKS**

APPROVED BY: **CECIL DILLON** DECEMBER 2015
CITY ENGINEER RCF 25835 DATE

STANDARD PLAN NO. 406

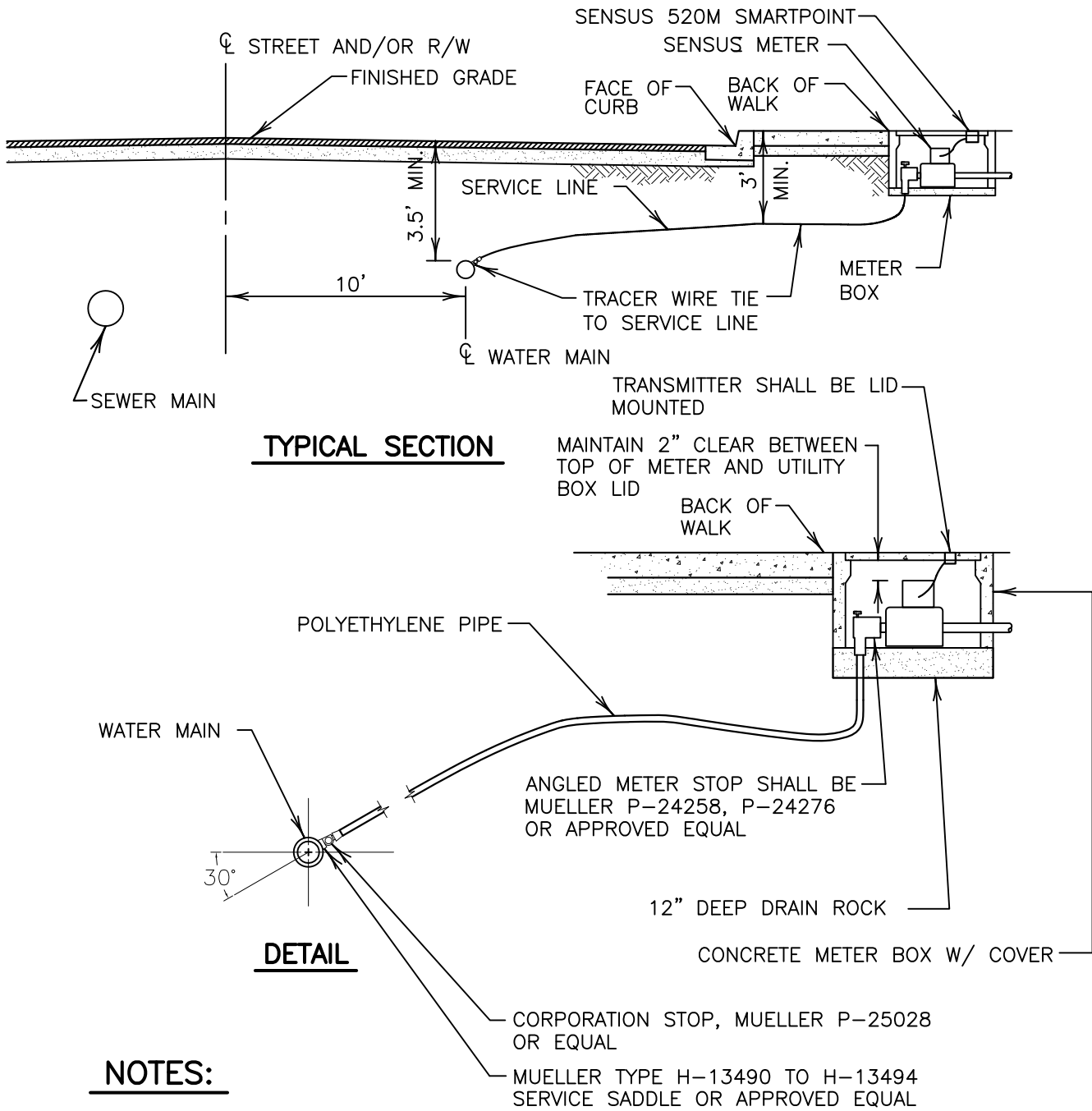

TYPICAL SECTION

DETAIL

NOTES:

- SERVICE TAP SHALL BE A MINIMUM OF 18" FROM ANY OTHER TAP, FLANGE OR JOINT ON THE WATER MAIN.
- CLEARANCE BETWEEN WATER AND SEWER SERVICE LINES SHALL BE 12" MIN. VERTICAL AND 18" HORIZONTAL.
- STAMP "W" IN 2-1/2" LETTERS ON TOP OF CURB AT SERVICE LOCATION.
- LARGER THAN 2" SERVICE SHALL BE APPROVED BY THE CITY ENGINEER.
- WATER METERS:
 SENSUS iPERL - 3/4" AND 1"
 SENSUS OMNI C2 - 1 1/2" AND LARGER
 METER BOXES:
 CHRISTY B16 WITH N16RP LID - 3/4" AND 1"
 CHRISTY N36 WITH N36RP LID - 1 1/2", 2", AND 3"
 CHRISTY B48 WITH TWO PIECE LID - 4"
- COMMERCIAL SERVICES REQUIRE BACKFLOW PROTECTION

NO.	REVISION	DATE	BY

DRAWN BY: EK, NR
 CHECKED BY: CD
 SCALE: NONE
 DATE: 03/2015

WATER SERVICE 1" TO 2"

CITY OF RIO VISTA
 DEPARTMENT OF PUBLIC WORKS

APPROVED BY: CECIL DILLON
 CITY ENGINEER
 RCE 25835
 DECEMBER 2015
 DATE

STANDARD PLAN NO. 501

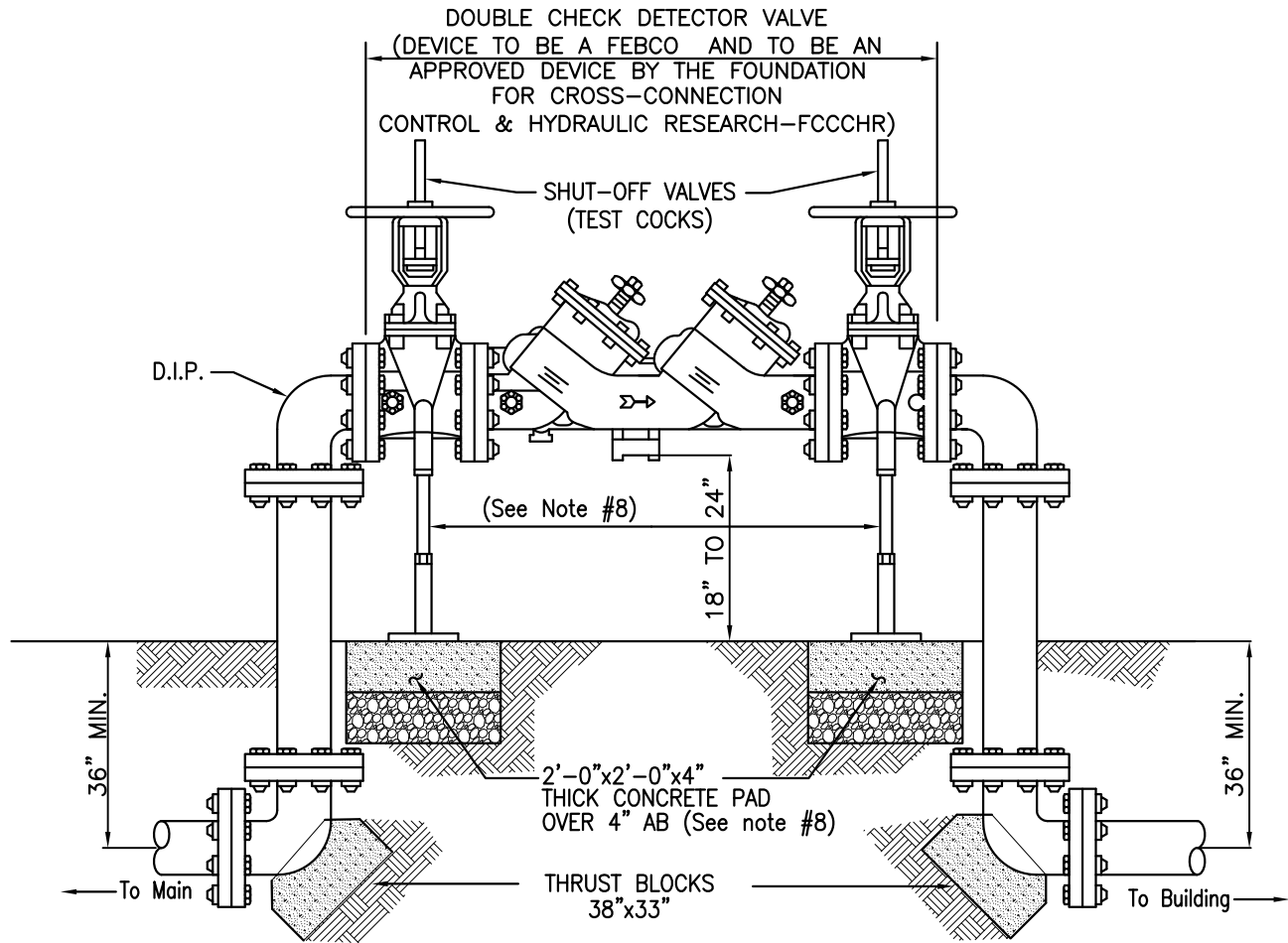

NOTES:

1. LOCATION OF DEVICE SHALL BE APPROVED PRIOR TO INSTALLATION.
2. RESILIENT SEAT GATE VALVES AND TEST COCKS ARE REQUIRED.
3. WATER SUPPLY-NO CONNECTIONS OR TEES WILL BE ALLOWED BETWEEN METER AND DEVICE.
4. PROTECTION FROM FREEZE DAMAGE IS RECOMMENDED IN EXPOSED AREAS.
5. DEVICE MUST BE ACCESSIBLE FOR TESTING AND MAINTENANCE.
6. BYPASS METER TO READ IN GALLONS.
7. PROVIDE COPIES OF BACKFLOW TESTS BY APPROVED TESTER TO THE CITY OF RIO VISTA PUBLIC WORKS DEPARTMENT.
8. D.C.D.A. BRACES ARE OPTIONAL FOR 6" AND SMALLER DEVICES UPON THE REQUIREMENT OF THE CITY ENGINEER.

NO.	REVISION	DATE	BY
DRAWN BY: BH, NR			
CHECKED BY: CD			
SCALE: NONE			
DATE: 03/2015			

**DOUBLE CHECK DETECTOR
ASSEMBLY**

**CITY OF RIO VISTA
DEPARTMENT OF PUBLIC WORKS**

APPROVED BY: DECEMBER
2015
CECIL DILLON
 CITY ENGINEER DATE
 RCF 25835

**STANDARD
PLAN NO. 502**

PIPING, VALVES, NIPPLES, ETC. SHALL BE THREADED BRASS FOR SIZES 2" OR LESS, AND SHALL BE FLANGED DUCTILE IRON FOR SIZES 3" OR GREATER.

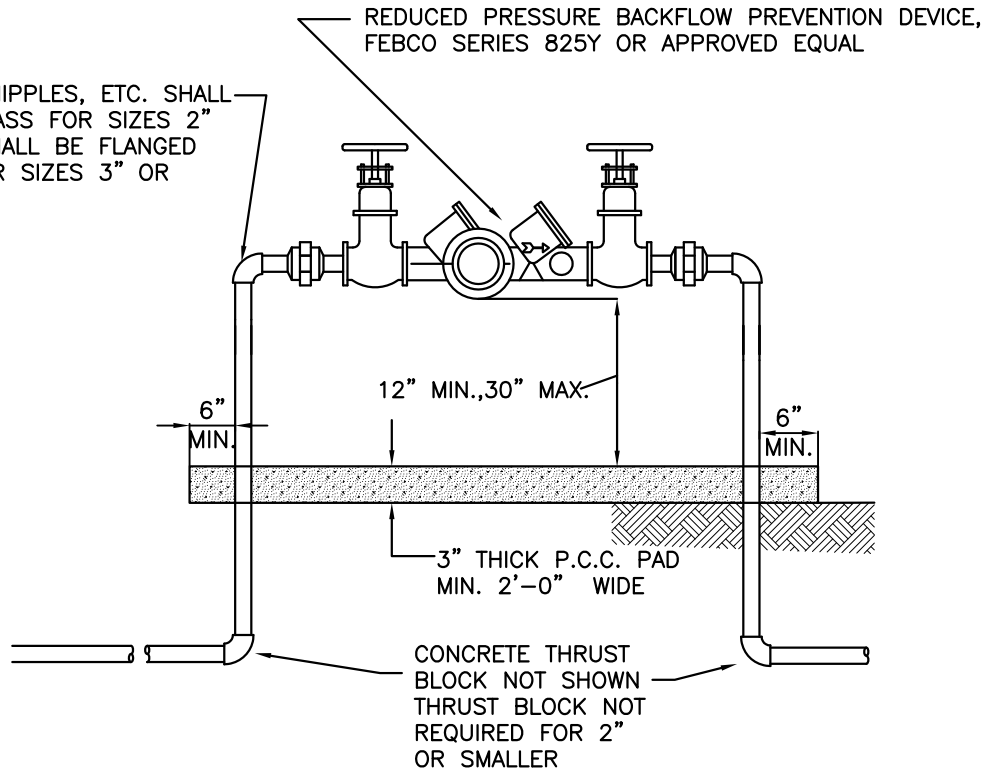

NOTES:

1. REDUCED-PRESSURE TYPE BACKFLOW PREVENTION DEVICES SHALL BE REQUIRED FOR ANY USE WHERE TOXIC MATERIALS ARE USED OR WHERE POSITIVE PROTECTION FOR THE PUBLIC WATER SUPPLY IS REQUIRED. TYPICAL APPLICATIONS INCLUDE; IRRIGATION SERVICES, COMMERCIAL SERVICES, INDUSTRIAL SERVICES, HOSPITALS, LABORATORIES, MORTUARIES, OR AS DETERMINED BY THE CITY. (TITLE 17 CALIF. ADMINISTRATION CODE)
2. CONNECTIONS BETWEEN THE CITY MAIN AND THE RP DEVICE SHALL BE AT THE DISCRETION OF THE CITY ENGINEER.
3. BACKFLOW PREVENTION DEVICES SHALL BE INSTALLED ADJACENT TO AND ON THE PROPERTY SIDE OF SIDEWALK WHERE APPLICABLE. THE ASSEMBLY SHALL BE INSTALLED AS CLOSE TO THE WATER METER LOCATION AS PRACTICAL.
4. DEVICE TO BE SAME SIZE OR LARGER THAN SERVICE METER.
5. LANDSCAPING OR OTHER SCREENING AROUND THE BACKFLOW DEVICE SHALL BE AS SHOWN ON APPROVED PLANS.
6. PROTECTION FROM FREEZE DAMAGE IS RECOMMENDED IN EXPOSED AREAS.

NO.	REVISION	DATE	BY
DRAWN BY: BH, NR			
CHECKED BY: CD			
SCALE: NONE			
DATE: 03/2015			

**REDUCED PRESSURE
BACKFLOW PREVENTER**

CITY OF RIO VISTA
DEPARTMENT OF PUBLIC WORKS

APPROVED BY: **CECIL DILLON** DECEMBER 2015
 CITY ENGINEER DATE
 RCF 25835

STANDARD PLAN NO. 503

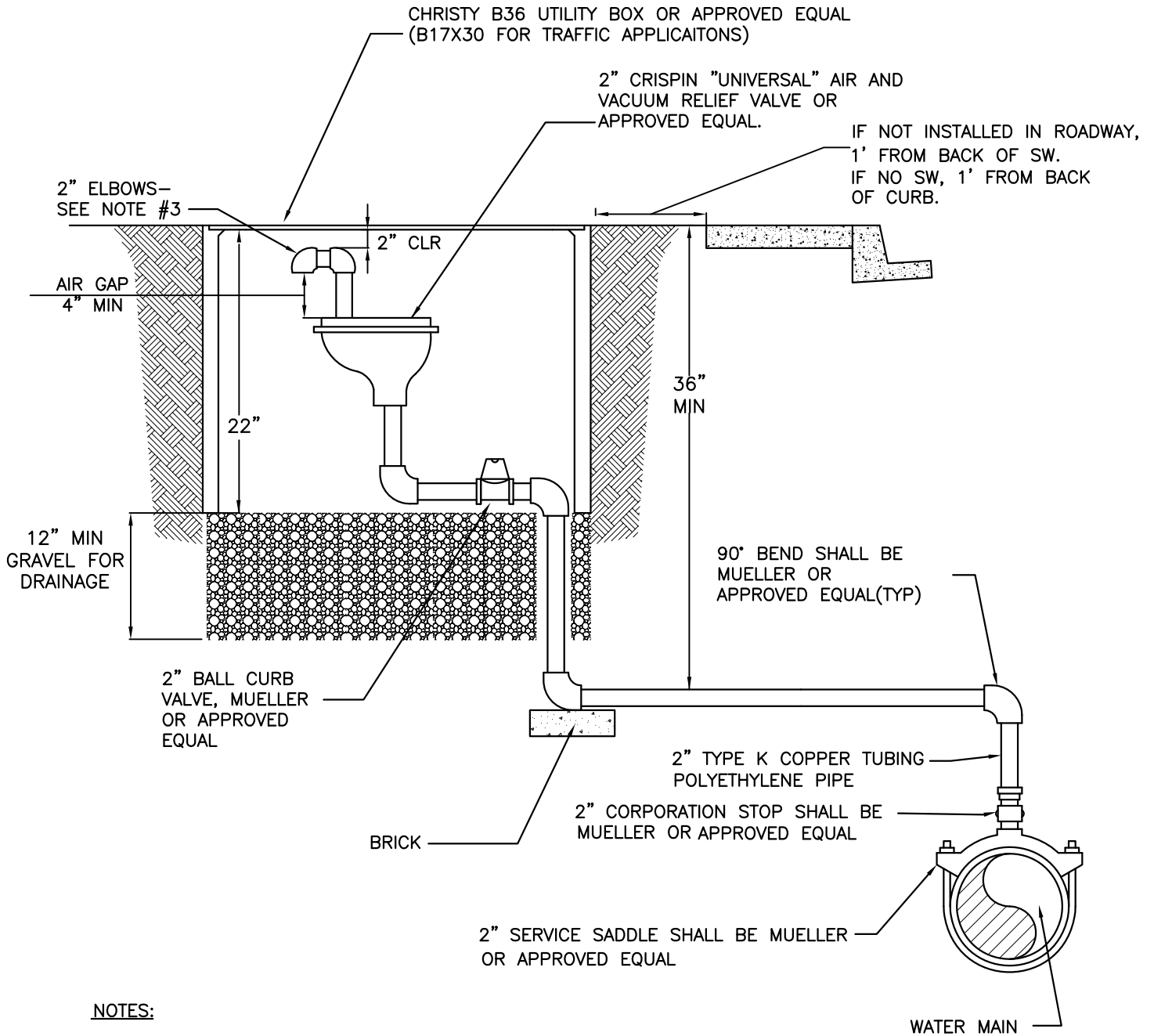

NOTES:

1. THE EXACT LOCATIONS OF THE AIR VALVE ASSEMBLIES WILL BE DETERMINED IN THE FIELD BY THE ENGINEER.
2. BEFORE INSTALLING COMPRESSION FITTINGS, REMOVE BURR FROM INSIDE AND RE-ROUND PIPE.
3. ATTACH SMALL MESH SCREEN WITH A STAINLESS STEEL HOSE CLAMP OVER OPENING.
4. SERVICE PIPE SHALL MAINTAIN CONTINUOUS UPWARD SLOPE FROM MAIN TO THE VALVE. POLYETHYLENE PIPE REQUIRES STIFFENERS AT VALVES.

NO.	REVISION	DATE	BY
DRAWN BY: BH			
CHECKED BY: CD			
SCALE: NONE			
DATE: 03/2015			

AIR VALVE ASSEMBLY

CITY OF RIO VISTA
DEPARTMENT OF PUBLIC WORKS

APPROVED BY: **CECIL DILLON** DECEMBER 2015
CITY ENGINEER DATE
RCF 25835

STANDARD PLAN NO. 504

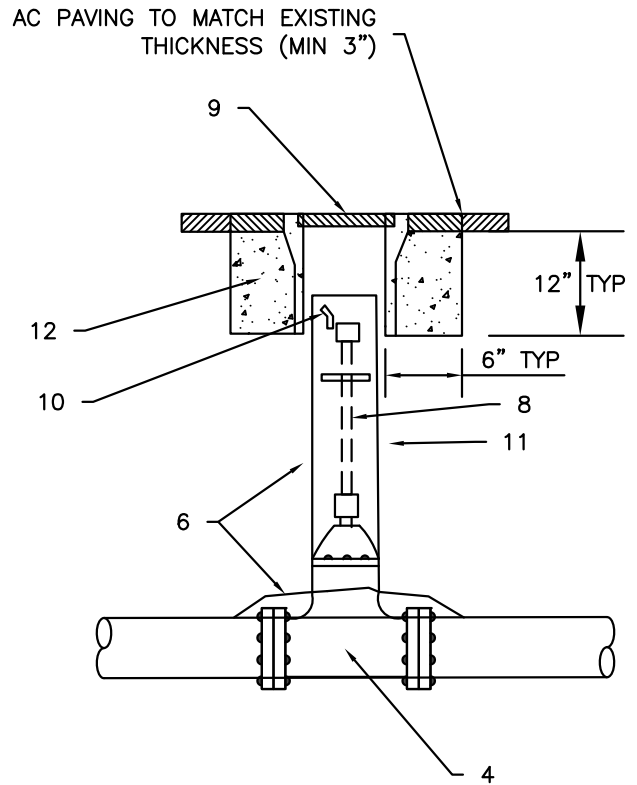
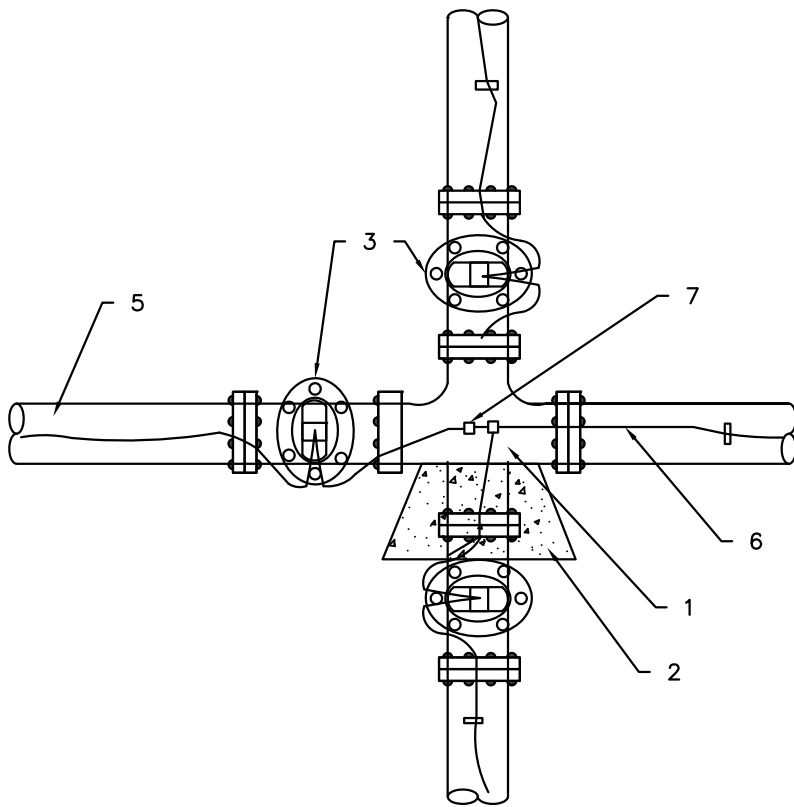

1. FLANGED TEE (OR CROSS). POLYWRAP.
2. THRUST BLOCK IF APPLICABLE.
3. FLANGED X MECHANICAL JOINT RESILIENT WEDGE GATE VALVES POLYWRAP.
4. VALVE – MUELLER A2360 OR APPROVED EQUAL.
5. PROPOSED WATER MAIN.
6. TRACER WIRE SHALL BE REQUIRED ON ALL NONFERROUS MAINS. TRACER WIRE SHALL BE SOLID COPPER WIRE WITH U.S.E. RATED INSULATION, COLOR YELLOW AND MINIMUM SIZE OF AWG #10 SECURE WIRE TO TOP OF PIPE WITH 10 MIL WRAPPING TAPE AT LEAST EVERY 10' PER DIVISION IV SECTION
7. TRACER WIRES SHALL BE INTERCONNECTED AT PIPE TEES AND CROSSES. SPLICES SHALL BE "KURNEY" (SPLIT BOLT) OR "KUPLETAP". INSTALLATION TAPE SHALL BE VINYL. ELECTRICAL WITH TWO COATS OF "SCOTCH KOTE."
8. PROVIDE EXTENSION IF OPERATING NUT EXCEEDS MAXIMUM OF 4' FROM FINISH GRADE. EXTENSION SHALL INCLUDE A STEADYING PLATE.
9. CHRISTY TYPE G-5 TRAFFIC BOX. LID SHALL READ "WATER".
10. PROVIDE NOTCH IN RISER FOR TRACER WIRE.
11. 8" PVC RISER TO BE PLUMB WITHIN 1".
12. CONCRETE COLLAR WITH 2" AC.

NOTES:

- A. ALL NUTS, BOLTS, AND WAHSERS ON FITTINGS SHALL BE STAINLESS STEEL TYPE 304.
- B. CONCRETE SHALL BE CLASS "A".

NO.	REVISION	DATE	BY	TYPICAL VALVE AND WATER MAIN INSTALLATION 6" THRU 12"	APPROVED BY:	DECEMBER
					CECIL DILLON	2015
					CITY ENGINEER	DATE
DRAWN BY: BH, NR				CITY OF RIO VISTA DEPARTMENT OF PUBLIC WORKS	RCE 25835	
CHECKED BY: CD						
SCALE: NONE						
DATE: 03/2015					STANDARD	505
					PLAN NO.	

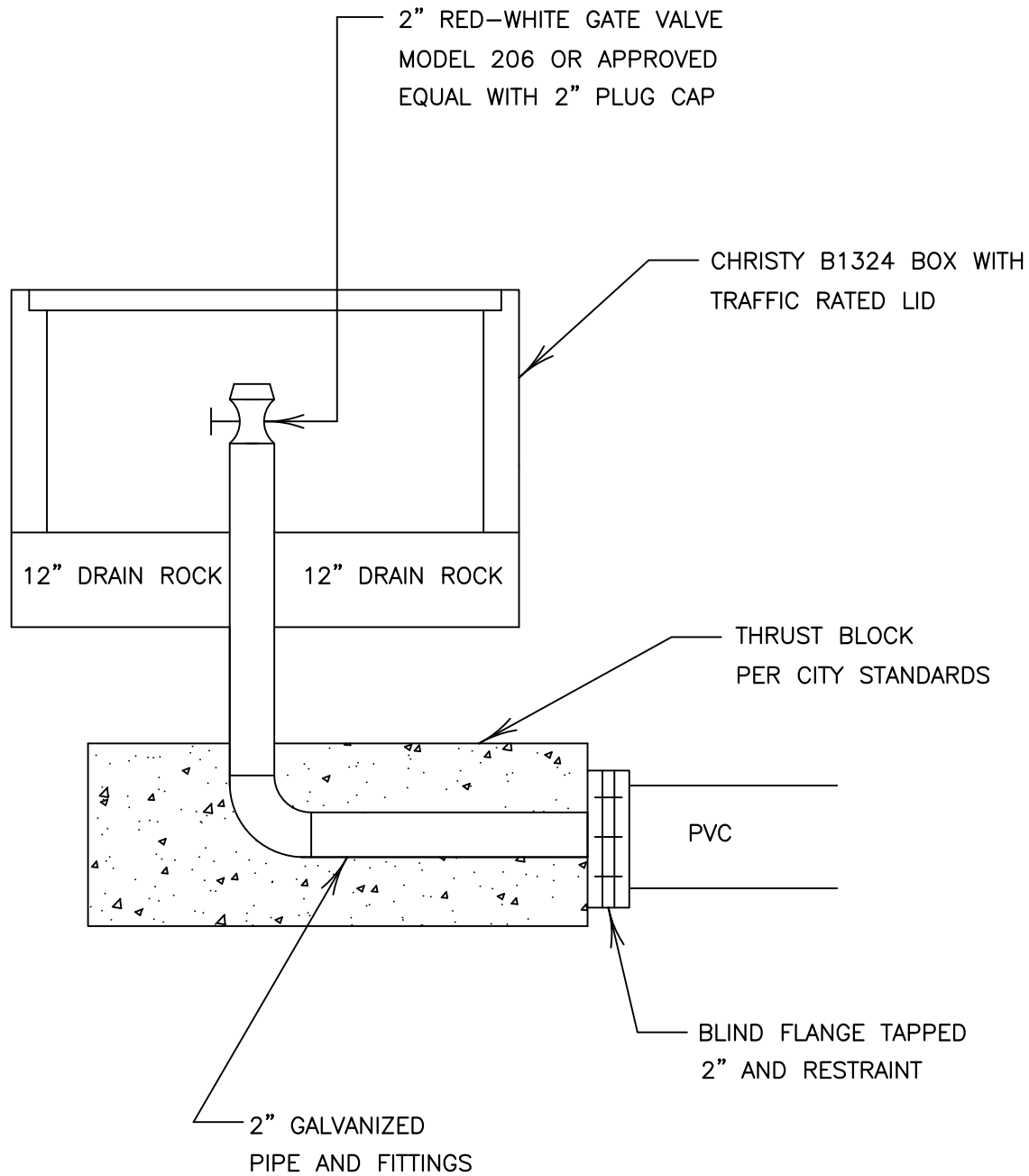

NO.	REVISION	DATE	BY
DRAWN BY: BH, NR			
CHECKED BY: CD			
SCALE: NONE			
DATE: 01/2015			

2" BLOWOFF

CITY OF RIO VISTA
DEPARTMENT OF PUBLIC WORKS

APPROVED BY: **CECIL DILLON** DECEMBER 2015
CITY ENGINEER DATE
RCF 25835

STANDARD PLAN NO. **506**

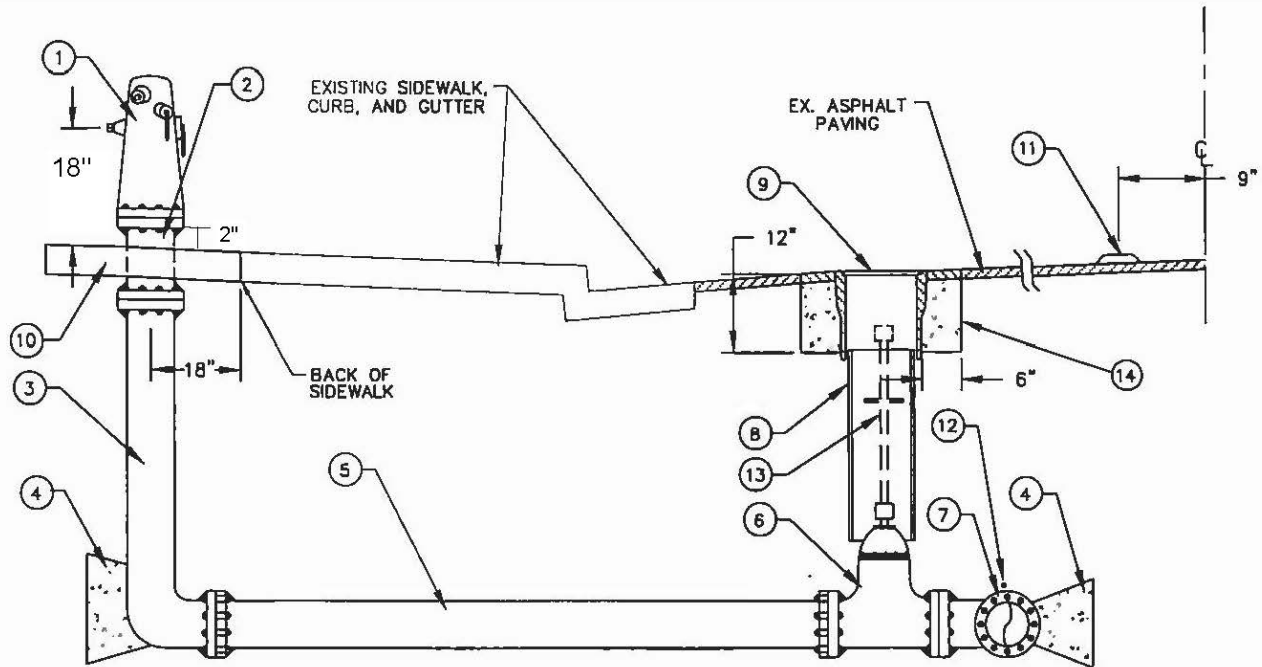

1. FIRE HYDRANT 4 1/2 INCH OUTLET SHALL FACE THE STREET. BOLTS ATTACHING FIRE HYDRANT TO BREAK-OFF TYPE, HEX HEAD, WITH THE HEAD ON TOP OF THE SPOOL FLANGE. HYDRANT SHALL BE LOCATED AT PROPERTY LINES, OUTSIDE OF CURB RETURN AREAS, AND AT LEAST 3 FEET FROM DRIVEWAYS WHERE POSSIBLE.
2. 12" BREAK-OFF SPOOL. BREAK-OFF GROOVE TO BE ABOVE CONCRETE. POLYWRAP SPOOL BELOW CONCRETE PAD.
3. BURY SECTION. FLANGED x MECHANICAL JOINT. (USE RESTRAINING GLAND) POLYWRAP.
4. CLASS "A" CONCRETE THRUST BLOCK. (SEE DETAIL #509)
5. 6 INCH PVC C900 OR DUCTILE IRON C151. POLYWRAP DUCTILE IRON PIPE.
6. 6 INCH RESILIENT WEDGE GATE VALVE. FLANGED x MECHANICAL JOINT(USE RESTRAINING GLAND IF REQUIRED.) POLYWRAP.
7. TEE WITH FLANGED CONNECTION FOR VALVE. POLYWRAP.
8. 8" PVC RISER. MUST BE PLUMB WITHIN 1 INCH.
9. CHRISTY TYPE G-5 TRAFFIC BOX. LID SHALL READ WATER.
10. 4 INCH MIN. THICKNESS CONCRETE PAD, 36 INCH x 36 INCH SQUARE CENTER FIRE HYDRANT IN PAD. SLOPE PAD TO MATCH SIDEWALK, CURB, OR FINISHED GRADE. (TYP. 2%)
11. REFLECTIVE BLUE MARKER (TYPE DB). AT INTERSECTIONS: TWO MARKERS SHALL BE INSTALLED PERPENDICULAR TO FIRE HYDRANT ON EACH STREET AND 9 INCHES OF CENTERLINE. (SEE DETAIL #508).

12. TRACER WIRE (SEE DETAIL #505).
13. PROVIDE EXTENSION IF OPERATING NUT EXCEEDS MAXIMUM OF FOUR (4) FEET FROM FINISHED GRADE. EXTENSION SHALL INCLUDE A STEADYING PLATE.
14. CONCRETE COLLAR WITH 2" AC.

NOTES:

- A. ALL NUTS, BOLTS, AND WASHERS ON FLANGED FITTINGS SHALL BE STAINLESS STEEL TYPE 304 EXCEPT FOR BREAK-OFF BOLTS. FITTINGS SHALL BE WRAPPED AND BEDDED IN SAND.
- B. WHERE NO R/W OR EASEMENT EXIST BEHIND NEW OR EXISTING SIDEWALK, AND FOR AREAS WITH SEPARATED SIDEWALK, INSTALL CENTER OF FIRE HYDRANT 18 INCHES BEHIND FACE OF CURB.
- C. CONCRETE SHALL BE CLASS "A"
- D. LOWEST STEM OF FIRE HYDRANT SHALL HAVE A MIN. CLEARANCE OF 18 INCHES.
- E. HYDRANT SHALL BE CLOW 960 PAINTED WITH ENAMEL, SAFETY YELLOW.

NO.	REVISION	DATE	BY
DRAWN BY: BH, NR			
CHECKED BY: CD			
SCALE: NONE			
DATE: 03/2015			

FIRE HYDRANT LATERAL AND VALVE ASSEMBLY

CITY OF RIO VISTA
DEPARTMENT OF PUBLIC WORKS

APPROVED BY: DECEMBER 2015
CECIL DILLON
CITY ENGINEER DATE
RCF 25835

STANDARD PLAN NO. 507

HYDRANT MARKER PLACEMENT AT INTERSECTIONS

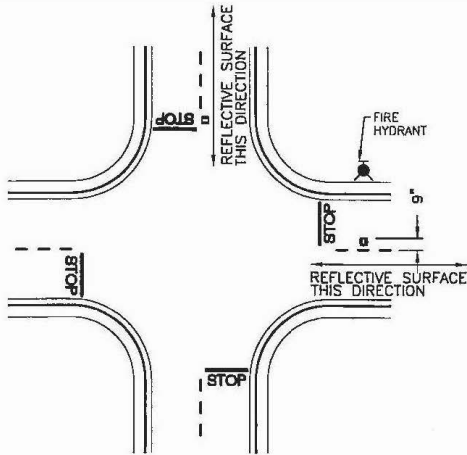

NOTE:

MARKERS ARE TYPICALLY PLACED OFF CENTER TO THE CORNER WHERE THE HYDRANT IS LOCATED. EACH MARKER SHOULD BE "TWO-WAY" MARKER SO IT'S REFLECTIVE SURFACE CAN BE VIEWED FROM BOTH DIRECTIONS BY ON COMING VEHICLES. TWO MARKERS ARE NORMALLY USED WITH THE REFLECTIVE SURFACES BEING ORIENTED 90 DEGREES FROM EACH OTHER SO THAT VEHICLES COMING FROM ANY DIRECTION CAN SEE THE MARKERS CLEARLY. MARKERS SHOULD BE OFFSET FROM EACH OTHER SO AS NOT TO BLOCK THE HEADLIGHT FROM HITTING THE REFLECTIVE SURFACE.

HYDRANT MARKER PLACEMENT AT MID BLOCK LOACTIONS

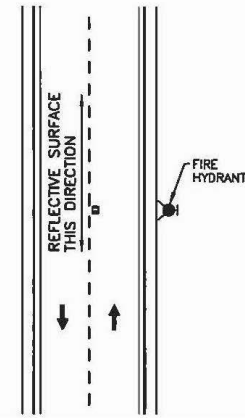

NOTE:

MARKERS FOR MID BLOCK LOCATIONS ARE TYPICALLY PLACED OFF CENTERLINE TO THE SIDE OF THE STREET WHERE THE HYDRANT IS LOCATED. EACH MARKER SHOULD BE A "TWO-WAY" MARKER SO IT'S REFLECTIVE SURFACE CAN BE VIEWED FROM BOTH DIRECTIONS BY ON COMING VEHICLES. THE MARKER SHOULD BE PLACED CLOSE ENOUGH TO THE CENTERLINE THAT IT CAN BE VIEWED EASILY FROM EITHER DIRECTION.

HYDRANT MARKER PLACEMENT MULTI LANE ROADS

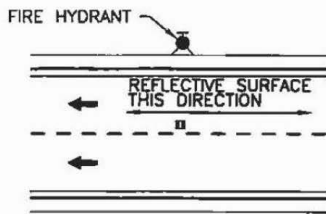

NOTE:

ON MULTI-LANE STREET WITH NO RAISED ROAD DOTS OR REFLECTORS, PLACE REFLECTOR 9" OFF CENTERLINE.

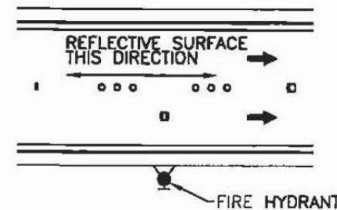

NOTE:

ON MULTI-LANE STEET WITH ROAD DOTS OR REFLECTORS, PLACE REFLECTOR IN THE MIDDLE OF THE LANE CLOSEST TO THE HYDRANT.





NO.	REVISION	DATE	BY
DRAWN BY: BH, NR			
CHECKED BY: CD			
SCALE: NONE			
DATE: 03/2015			

HYDRANT MARKER (BLUE DOT) LOCATIONS

CITY OF RIO VISTA
DEPARTMENT OF PUBLIC WORKS

APPROVED BY:	DECEMBER
CECIL DILLON	2015
CITY ENGINEER	DATE
RCF 25835	

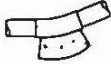
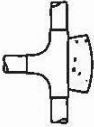
STANDARD
PLAN NO. **508**

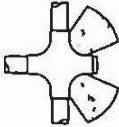
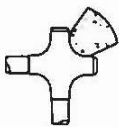
FITTING TYPE		90° BEND	45° BEND	11 1/4° OR 22 1/2° BEND	TEE OR DEAD END	TEE W/ PLUG	CROSS W/ PLUG	CROSS W/ PLUGS
TYPICAL INSTALLATION								
PIPE SIZE	4"	2	1	1	2	2	2 EA.	2
	6"	4	2	1	3	4	4 EA.	4
	8"	7	4	2	5	7	7 EA.	7
	10"	12	6	3	8	12	12 EA.	12
	12"	16	10	5	12	16	16 EA.	16
	14"	23	13	7	16	23	23 EA.	23
	16"	29	16	8	20	29	29 EA.	29

1. NUMBERS IN TABLE ABOVE ARE REQUIRED MINIMUM BEARING AREAS IN SQUARE FEET.
2. THRUST BLOCKS SHALL BE CONSTRUCTED OF CLASS "A" CONCRETE.
3. AREAS GIVEN ARE FOR CLASS 150 PIPE AT 150 PSI TEST PRESSURE IN SOILS WITH 2,000 PSF BEARING CAPACITY.
4. THRUST BLOCKS SHALL BE PLACED AGAINST UNDISTURBED SOIL.
5. STRAPS USED FOR ANCHORING PIPE TO THRUST SHALL BE STAINLESS STEEL ONLY.
6. PIPE FITTINGS SHALL BE PROTECTED WITH MINIMUM 8 MIL VISCUINE IN ORDER THAT NO CONCRETE WILL TOUCH THE FITTING OR JOINT UPON THRUST BLOCK PLACEMENT.
7. A SOILS REPORT SHALL BE PROVIDED UPON REQUEST BY THE CITY ENGINEER.
8. THIS TABLE IS NOT APPLICABLE TO THE DESIGN OF ON-SITE FIRE SUPPRESSION WATER MAINS.

NO.	REVISION	DATE	BY	THRUST BLOCK BEARING AREA DETAIL	APPROVED BY:	DECEMBER
					CECIL DILLON	2015
DRAWN BY: BH, NR				CITY OF RIO VISTA DEPARTMENT OF PUBLIC WORKS	CITY ENGINEER	DATE
CHECKED BY: CD					RCE 25835	
SCALE: NONE					STANDARD	509
DATE: 03/2015					PLAN NO.	

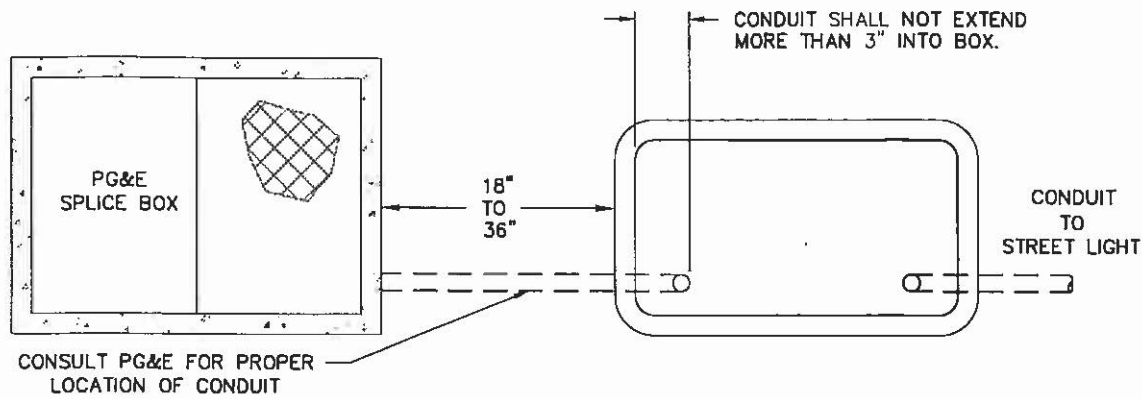

PLAN VIEW

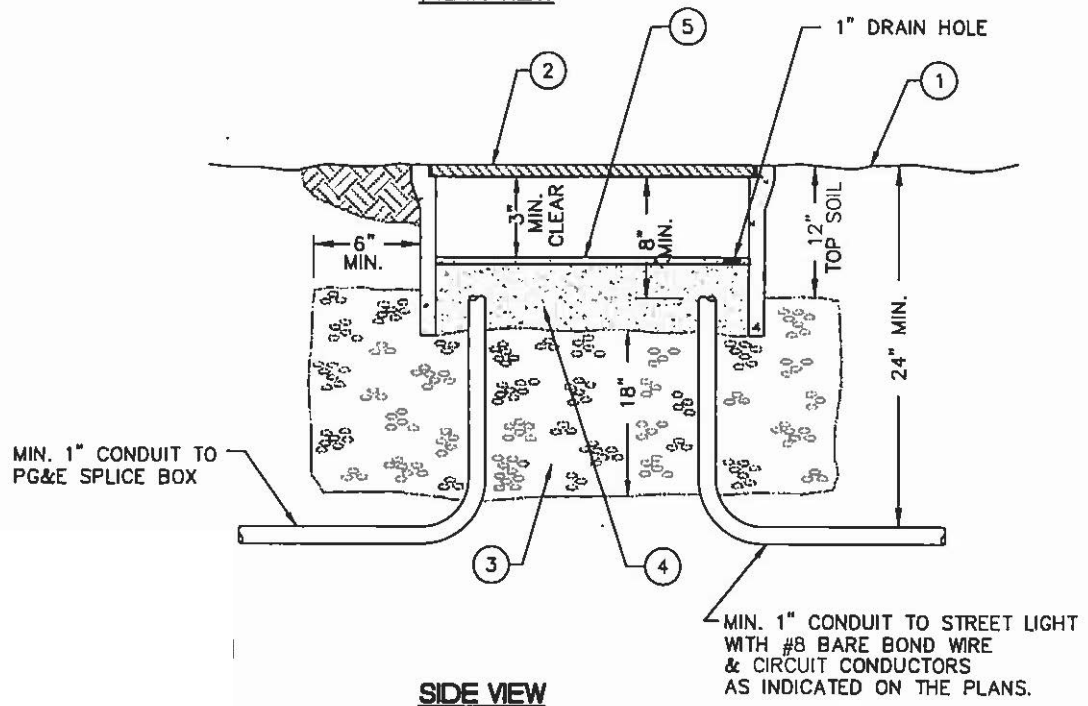

SIDE VIEW

1. FINISH GRADE
2. MIN. #3 1/2 STATE BOX (STD. ES-8) WITH COVER MARKER "STREET LIGHTS" (CHRISTY N9 OR EQUAL).
3. DRAIN ROCK BACKFILL.
4. PLACE SAND BACKFILL TO COMPLETERLY COVER CONDUITS AND CONDUCTORS.
5. 2" OF 2-SACK SLURRY.

NOTES:

- A. INSTALL CONDUIT AND CONDUCTORS TO PG&E SECONDARY SPLICE BOX. PG&E WILL PROVIDE CONNECTION WITHIN SPLICE BOX.
- B. INSTALL DUCT SEAL IN CONDUIT ENDS.
- C. THE STEET LIGHT CABLE MUST COME UP INTO THE SAME END OF THE BOX AS ALL OF THE OTHER CABLES.

NO.	REVISION	DATE	BY
DRAWN BY: BH, NR			
CHECKED BY: CD			
SCALE: NONE			
DATE: 01/2015			

STREET LIGHT SERVICE POLE

CITY OF RIO VISTA
DEPARTMENT OF PUBLIC WORKS

APPROVED BY: **CECIL DILLON** DECEMBER 2015
CITY ENGINEER
RCF 25835 DATE

STANDARD PLAN NO. 601

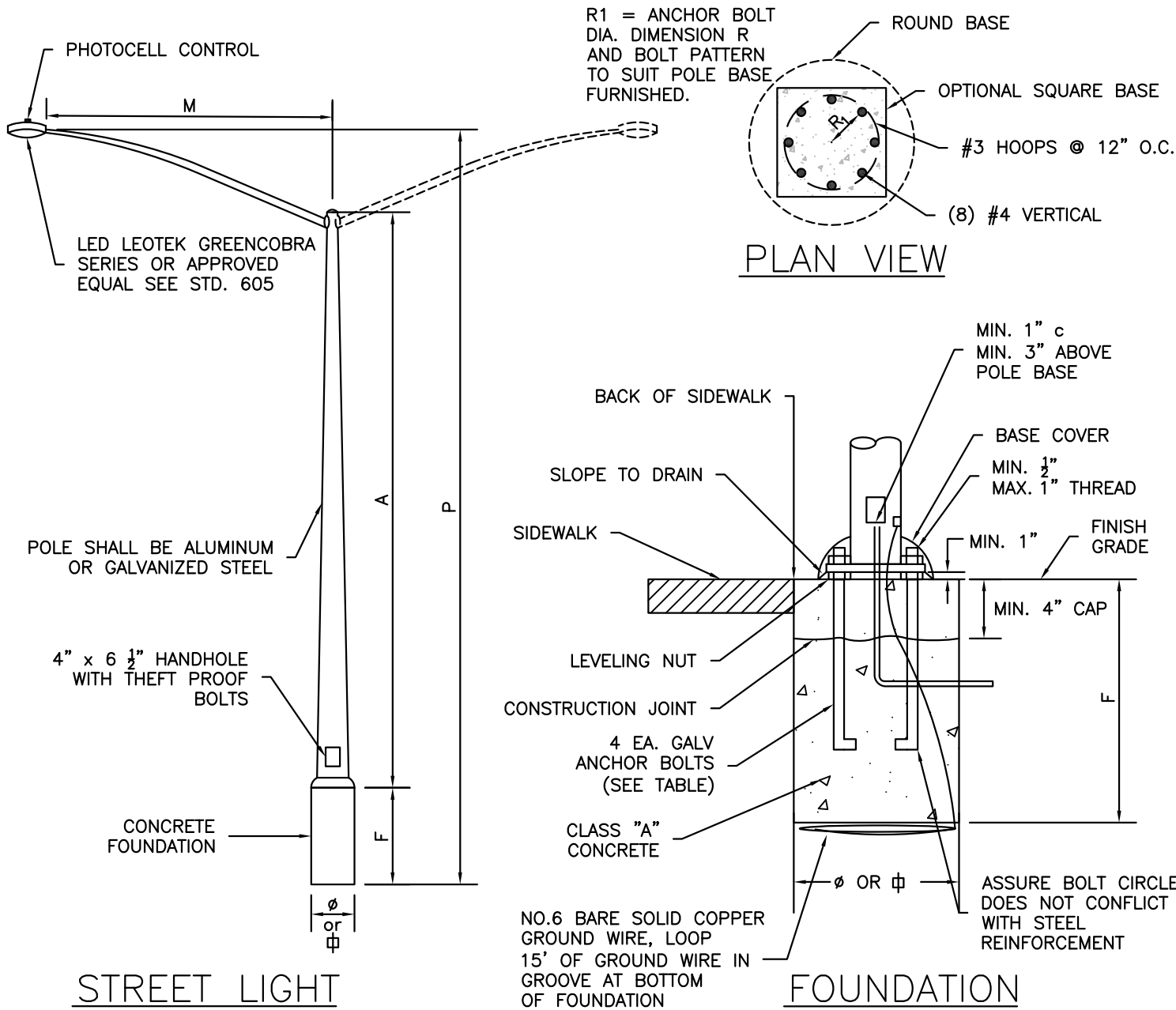

STREET LIGHT

FOUNDATION

	POLE DATA			ARM	FOUNDATION		ANCHOR BOLTS	
	A HEIGHT	P MTG. HGT	ACCEPTABLE PRODUCTS	M LENGTH	F DEPTH	∅ DIA	∅ SQ	SIZE
MINOR & COLLECTOR	25'-0"	27'-6"	HAPCO 21 SERIES, UNION METAL 203, AMERON SERIES PL OR APPROVED EQUAL	4' MINOR 6' COLL.	5'-0"	2'-0"	1'-8"	1" x 36" x 4"
MAJOR & ARTERIAL	30'-0"	32'-6"		8'-0"	5'-0"	2'-6"	2'-3"	1" x 36" x 4"

- NOTES:**
- A. PULL BOX SHALL BE INSTALLED ADJACENT TO POLE WITHIN 36". PULL BOX SHALL NOT BE LOCATED IN SIDEWALK WITHOUT PRIOR APPROVAL OF THE CITY ENGINEER.
 - B. WHEN A SECONDARY PULL BOX IS LOCATED WITHIN 8' OF POLE, PULL BOX IS NOT REQUIRED.
 - C. POLE LOCATION SHALL BE AT BACK OF SIDEWALK. IN THE CASE OF NO SIDEWALK OR SEPARATED SIDEWALK, POLE SHALL BE 2' BEHIND FACE OF CURB. ALTERNATE LOCATIONS SHALL BE AT THE DISCRETION OF THE CITY ENGINEER.

NO.	REVISION DATE	BY	STANDARD STREET LIGHT	APPROVED BY:	DECEMBER 2015
				CECIL DILLON	DATE
DRAWN BY: BH, NR			CITY OF RIO VISTA DEPARTMENT OF PUBLIC WORKS	CITY ENGINEER	
CHECKED BY: CD				RCE 25835	
SCALE: NONE				STANDARD PLAN NO. 602	
DATE: 01/2015					

INTERSECTION WITH 2-LANE STREET

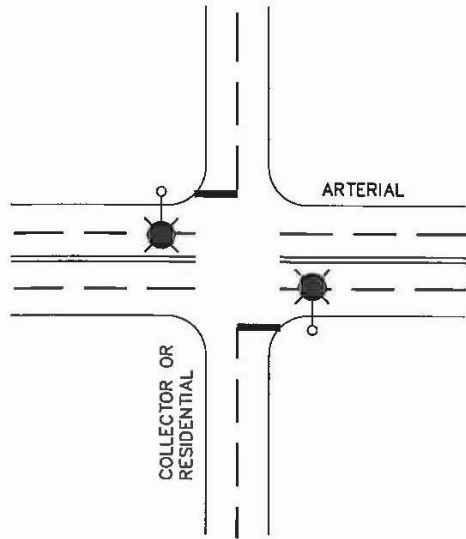

INTERSECTION WITH 4-LANE STREET

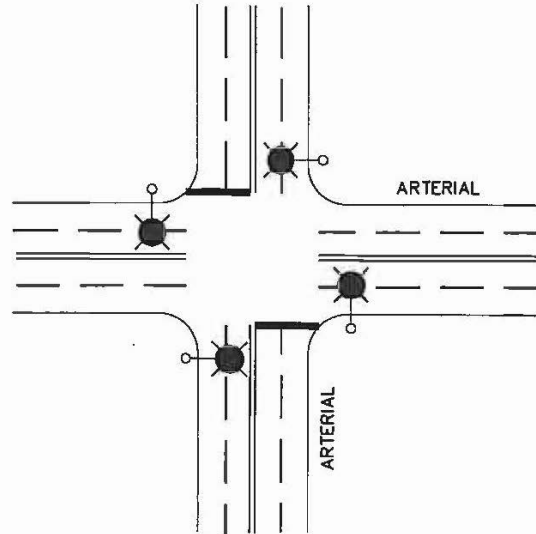

TEE INTERSECTIONS

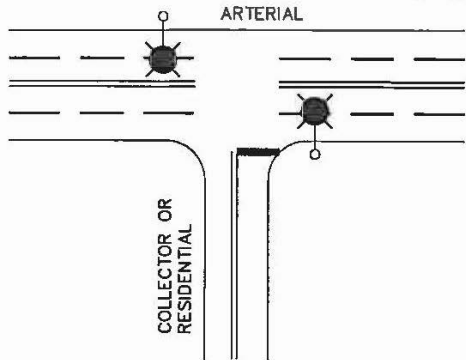

COLLECTOR

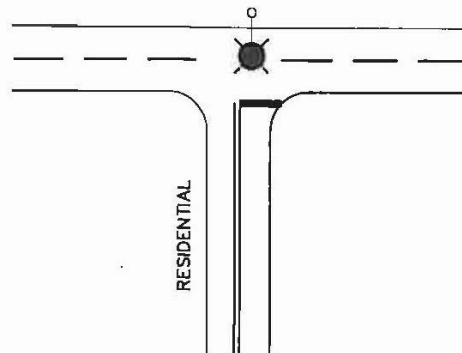

NOTE:

LOCATE STREET LIGHTS ON TRAFFIC SIGNAL POLES WHENEVER POSSIBLE AT SIGNALIZED INTERSECTIONS.

NO.	REVISION	DATE	BY
DRAWN BY: BH, NR			
CHECKED BY: CD			
SCALE: NONE			
DATE: 01/2015			

INTERSECTION LIGHTING

CITY OF RIO VISTA
DEPARTMENT OF PUBLIC WORKS

APPROVED BY:	DECEMBER
CECIL DILLON	2015
CITY ENGINEER	DATE
RCE 25835	

STANDARD PLAN NO. 603

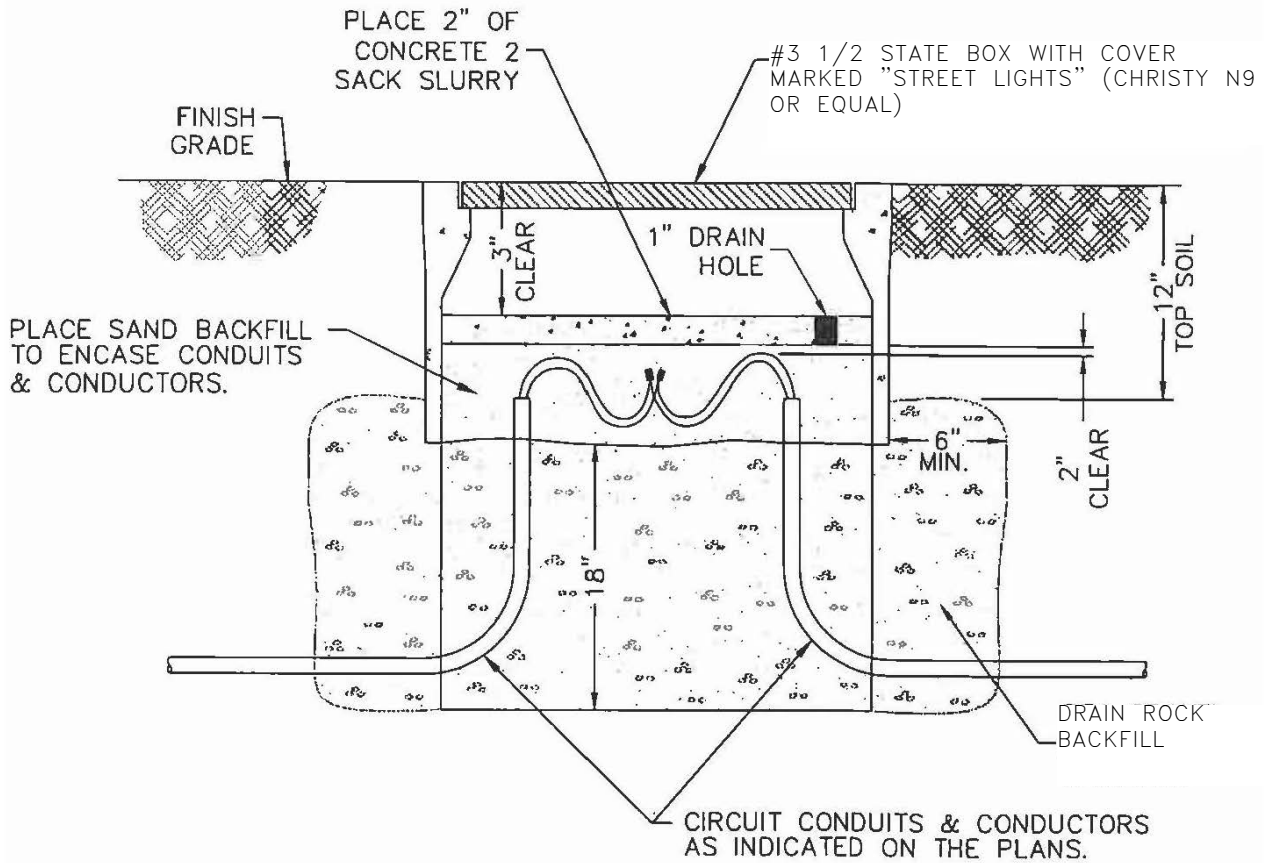

CROSS SECTION

NOTE:

CONDUCTORS & CONDUITS SHALL BE WRAPPED WITH 8 MIL POLYETHELENE ENCASEMENT PRIOR TO PLACING SAND BACKFILL.

NO.	REVISION	DATE	BY
DRAWN BY: BH, NR			
CHECKED BY: CD			
SCALE: NONE			
DATE: 01/2015			

**STREET LIGHT CONDUITS &
CONDUCTORS ENCASEMENT**

**CITY OF RIO VISTA
DEPARTMENT OF PUBLIC WORKS**

APPROVED BY:	DECEMBER
CECIL DILLON	2015
CITY ENGINEER	DATE
RCE 25835	

STANDARD PLAN NO. 604

ROADWAY CLASS	LIGHT SPACING (FT)	LUMINAIRE WATT	MIN. AVG. MAINTAINED FC	UNIFORMITY RATIO AVG. FC/MIN. FC
MINOR	200	38w LED	0.20	5:1
COLLECTOR	200	48w LED	0.30	4:1
MAJOR & ARTERIAL	100	58w LED	0.70	3:1

NOTES:

1. FC = FOOT-CANDLE
2. LUMINAIRES SHALL BE LEOTEK GREENCOBRA SERIES WITH PHOTOCELL CONTROL OR APPROVED EQUAL. FINISH SHALL BE GREY

NO.	REVISION	DATE	BY	ROADWAY ILLUMINATION	APPROVED BY:	DECEMBER
					CECIL DILLON	2015
DRAWN BY: BH, NR				CITY OF RIO VISTA DEPARTMENT OF PUBLIC WORKS	CITY ENGINEER	DATE
CHECKED BY: CD					RCE 25835	
SCALE: NONE					STANDARD	605
DATE: 01/2015					PLAN NO.	